

МІНІСТЕРСТВО ОСВІТИ І НАУКИ УКРАЇНИ
Національний авіаційний університет

БУДІВЕЛЬНІ КОНСТРУКЦІЇ

Методичні вказівки і контрольні завдання. Приклади

для студентів спеціальностей

8.092101 “Промислове та цивільне будівництво”

8.092105 “Автомобільні дороги та аеродроми”

Київ 2007

MINISTRY OF EDUCATION AND SCIENCE OF UKRAINE
National Aviation University

BUILDING CONSTRUCTIONS

Methodical Guide and check task, Example
for Students of Specialties

8.092101 “Industrial and Civil Construction”

8.092105 “Highways and Aerodromes”

Kyiv 2007

УДК 624.01:725.39(076.5)

ББК Н50р

Б 903

Автори: В.М.Першаков, В.С.Горбатов, Т.В.Тугай.

Рецензент: д.т.н., проф. Б.М.Лисицин

Затверджено на засіданні секції ради Інституту міського господарства НАУ 4 червня 2007 року.

Б 903 Будівельні конструкції. Методичні вказівки і контрольні завдання. Приклади. / В.М.Першаков, В.С.Горбатов, Т.В.Тугай. – К.: НАУ, 2007. –33 с.

Наведені алгоритми та приклади розрахунку металевих конструкцій, методичні вказівки та контрольні завдання з дисципліни “Будівельні конструкції”.

Для студентів четвертого, п'ятого курсу факультету аеропортів Інституту міського господарства денної та заочної форми навчання спеціальностей:

8.092101 “Промислове і цивільне будівництво”,

8.092105 “Автомобільні дороги та аеродроми”,

а також для студентів, що навчаються англійською мовою.

Authors: V.M.Pershakov, V.S.Gorbatov, T.V.Tugay.

Reviewer: prof. B.M.Lisizin

Approved by NAU Institute of municipal economy Editorial Board Division on 1 June, 2007.

Б 903 Building constructions. Methodical Guide and check tasks.

Example. / V.M.Pershakov, V.S.Gorbatov, T.V.Tugay.

- K.: NAU, 2007. –33 p.

This methodical guide contains algorithms and calculation examples metal construction. Check tasks in the subject "Building constructions". Designed for students of the fourth and fifth years of the faculty of airports of the Institute of municipal economy of the full time and correspondence form of training in specialties:

8.092101 "Industrial and civil construction",

8.092105 "Highways and aerodromes”,

as well as students studying in English.

PROBLEM #1

Problem task. Choose the cross-section of flooring beam from rolled I-section for beam grid of normal type with metal flooring and the cell dimensions 12x6m (by the initial data of table 1). The calculation of the main beam isn't considered here.

PROBLEM #1 SOLUTION ORDER

1. Develop the structural scheme of flooring. In the scale set draw the plan and cross-section of flooring with the depiction of loading area on the flooring beam.
2. Choose the calculation scheme of the flooring beam. In the given case the flooring beam is considered as freely-supported single-span beam loaded uniformly by distributed load ($l=6$ m).
3. Determine the design loading. The design loading, distributed per one linear meter of the beam is: $q = (q^H \gamma_{fg} + p^H \gamma_{fp})a$;

where $\gamma_{fg} = 1,1$ and $\gamma_{fp} = 1,2$ - are safety factors by load correspondingly for dead and temporary loading; $q^H = 78,5 \text{ kN/m}^2$ - own weight of the flooring (where t – thickness of flooring in meters).
Initial data for problem #1 Table 1.

Letter number	Initial data	Surname letters									
		A Л, Т	Б Й У	В К Ф	Г Л Х	Д М Ц	Е Н Ч	Є О Ш	Ж П Щ	З Р Ю	И С Я,Б
1	Temporary basic load, kN/m^2	20	22	24	26	28	21	23	25	27	19
2	The step of transverse beams a, cm	140	120	100	80	60	150	170	110	90	180
3	Steel flooring of thickness, mm	8	10	12	12	14	10	12	12	14	8
4	Steel brand for beams	18сп	ВСт3сп	18Гсп	09Г2С	10Г2С1	18Гсп	18Гсп	15ХСНД	14Г2	ВСт3сп
5	Ultimate sag of flooring beams	$\frac{1}{250}$	$\frac{1}{200}$	$\frac{1}{270}$	$\frac{1}{270}$	$\frac{1}{270}$	$\frac{1}{270}$	$\frac{1}{270}$	$\frac{1}{270}$	$\frac{1}{270}$	$\frac{1}{270}$

4. Determine the design stresses. Maximal design bending moment

$$M = ql^2 / 8$$

5. Choose and check the beam's cross-section dimensions. By the formula determine the moment of resistance of the beam.

$$W_{req} = M/R_y \gamma_c,$$

by which according to the table of assortments (ГОСТ 8239)* choose the cross-section of I-section beam and perform it's check-up by the formulas:

$$M/W_{n,min} \leq R_y \gamma_c; \quad \tau = \varphi_s / I_t \leq R_y \gamma_c; \quad M/\varphi_b W_c \leq R_y \gamma_c;$$

6. Check the rigidity of the beam. Determine the value of sag f due to the normal load

$$q = (q^H + p^H)a; \quad f = 5q^H l^4 / 384EI_x$$

Compare the obtained value to the ultimate one.

EXAMPLE #1

Set the cross-section of flooring beam from rolled I-section for beam grid of normal type with metal flooring and cell dimensions 12x6m. The calculation of the main beam isn't considered here.

Initial data:

- Temporary basic loading along the flooring $p=21 \text{ kN/m}^2$;
- The step of flooring beams $a=150 \text{ cm}$;
- Steel flooring of thickness $\delta = 12 \text{ mm}$;
- Steel brand for beams: I0 Г2С1 ($R_y=330 \text{ MPa}$);
- Ultimate sag for flooring beams: $[f/l]=[1/250]$;
- Safety factor $\gamma_c = 0,9$

Solution

1. The structural scheme of flooring is worked out. There should be drawn the scheme of flooring with the depiction of loading area of the flooring beam.

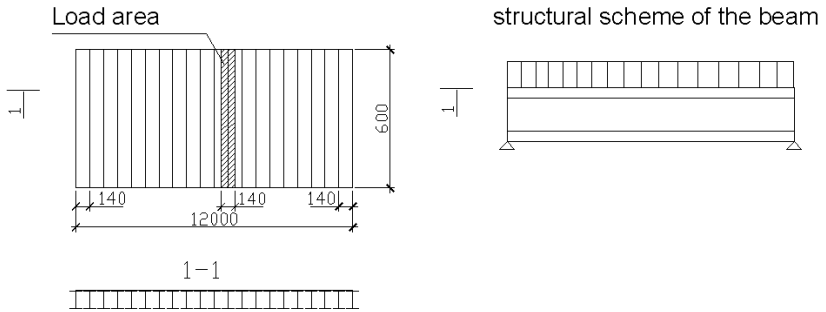

Fig. 1 Structural scheme of flooring

2. Choice of design flooring beam. Freely-supported single-span beam is uniformly loaded with distributed load.

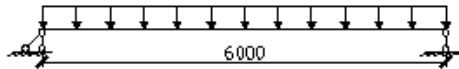

Fig. 2. Flooring beam scheme

3. Determination of the design load

Let's gather the loads:

- Own weight of flooring

$$q^H = q^H \cdot a = 78,5 \cdot 0,012 = 0,94 \text{ kN/m};$$

- basic load

$$q^H = (78.5 \cdot 0.012 + 21)1.5 = 32.8 \text{ kN/m};$$

- design load

$$q = (q^H \gamma_{fp} + V \gamma_{fv})a = (0,94 \cdot 1,1 + 21 \cdot 1,2) \cdot 1,5 = 39,4 \text{ kN/m};$$

where $\gamma_{fp} = 1,1$, $\gamma_{fv} = 1,2$ - safety factor by loadings – dead and temporary ones.

4. Determine the design stresses in the beam:

Design bending moment:

$$M = (ql^2)/8 = (39,4 \cdot 6^2)/8 = 177,3 \text{ kN/m};$$

- On the areas close to the supports:

$$Q = (ql) / 2 = (39,4 \cdot 6) / 2 = 118 \text{ кN};$$

5. The cross-section dimensions are determined according to the conditions of strength by basic stress in the middle cross-section of the beam (that is by the condition $\sigma = M / W \leq R_y \gamma_c$ - the conditions of first group of limit states).

$$W_{req} = M / (R_y \gamma_c) = (177,3 \cdot 10^3) / (330 \cdot 10^2 \cdot 0,9) = 596 \text{ cm}^3$$

$$\gamma_c = 0,9; R_y = 330 \text{ MPa} \approx 33 \text{ кN} / \text{cm}^2;$$

$$1 \text{ MPa} = 0,1 \text{ кN} / \text{cm}^2; 1 \text{ MPa} = 10 \text{ kg} / \text{cm}^2$$

We accept the I-section № 33, by ГОСТ 8239 its parameters:

$$W_x = 597 \text{ M cm}^3 > W_{TP} = 596 \text{ cm}^3,$$

$$I_x = 9840 \text{ cm}^4, \delta = 11,2 \text{ mm}, S_x = 339 \text{ cm}^3,$$

$$E = 2,06 \cdot 10^5 \text{ MPa}, h = 330 \text{ mm}.$$

6. The strength of the beam is checked also in the area close to the support by shearing stress (that is the condition $\tau = (QS_x) / (I_x \delta) \leq R_s \gamma_c$ is true).

$$(QS_x) / (I_x \delta) = (118 \cdot 339) / (9840 \cdot 1,12) = 3,6 \text{ кH} / \text{cm}^2 = 36 \text{ MPa}$$

$$36 \text{ МПа} < 191 \cdot 0,9 = 172 \text{ MPa}$$

7. Check the rigidity of the beam in the middle of the span by the relative sag:

$$[f/l] = (5/384) [(ql^4) / (EI_x)];$$

$$[f/l] = (5/384) [(32,8 \cdot 10 \cdot 600^4) / (2,06 \cdot 10^5 \cdot 100 \cdot 9840)] = 2,73 / 600;$$

$$[1/220] > [f/l] = [1/250].$$

The rigidity of the beam isn't sufficient. Accept another I-section beam.

Accept I-section № 36 ГОСТ 8239 with $I_x = 13380 \text{ cm}^4$, then:

$$[f/l] = (5/384) [(32,8 \cdot 10 \cdot 600^4) / (2,06 \cdot 10^5 \cdot 100 \cdot 13380)];$$

$$[1/225] > [f/l] = [1/250]$$

The obtained value of the relative sag is less than the ultimate one.

Thus, beam rigidity is provided.

PROBLEM #2

Problem task. Choose the cross-section of steel axially compressed column of solid cross-section of length l . The stress in the column from normative loads: constant – G kN, temporary – P kN. The value of loadings, restraint conditions variants and other initial data is given in table 2.

Initial data for problem 2

Table 2.

Letter number	Initial data	Surname letters									
		А І, І Т	Б Й У	В К Ф	Г Л Х	Д М Ц	Е Н Ч	Є О Ш	Ж П Щ	З Р Ю	И С Я, Ъ
1	Securing scheme	б	в	г	б	б	а	в	а	б	г
2	l, m	6.2	6.5	6.8	7.5	7.0	6.8	7.2	7.4	б. 4	6.0
3	Steel brand	C235	C245	C255	C275	C285	C285	C275	C255	C245	C235
4	G, kN	1100	1000	1200	1050	980	1010	920	1400	1300	1150
5	P, kN	2400	2500	2400	2600	2100	2200	2300	2400	2400	2600

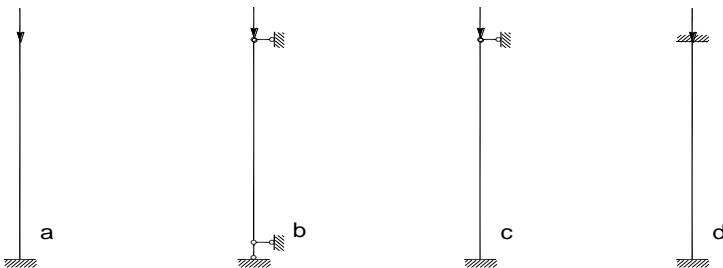

Fig. 3. Restraint conditions variants

PROBLEM #2 SOLUTION ORDER

1. Determine the design stress in the bar of the column $N = P \cdot \gamma_{fp} + Q \gamma_{fg}$; the values γ_{fp} and γ_{fg} should be taken from problem #1.
2. Cross-section dimensions determination. Accept the column's cross-section as welded from three steel sheets, for which the radii of inertia can be defined according to the approximated formulas: $i_x = 0.43h$; $i_y = 0.24b$ (Fig. 4).

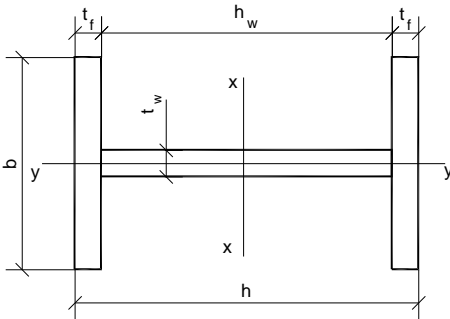

Fig.4 Column's cross-section

3. Choose the column's cross-section area. Determine the design length of column $l_0 = \mu l$. Coefficient μ should be taken depending on the restraint conditions: for scheme a ($\mu = 2$); for scheme b ($\mu = 1$); for c ($\mu = 0.7$); for scheme d ($\mu = 0.5$).

Having set the flexibility in the limits $\lambda = 60 - 90$, depending on the steel brand determine the value of coefficient φ (appendix 2, table 7)/14/. Determine the necessary area of cross-section $A = N / \varphi R_y \gamma_c$; the required radius of inertia $i_{req} = l_0 / \lambda$; the required width of cross-section $b = i_{req} / 0.24$ (Fig.4.) Setting the depth close to the width b , determine the dimensions of the sheets of rolled universal steel by the standard. The thickness of wall can be accepted in the limits $t_w = (0.5-0.7)t_f$.

4. Check the cross-section. Determine the moments of inertia of cross-sections in both main plains. According to the smaller moment of inertia determine the minimum radius of inertia $i_{min} = \sqrt{I_{min} / A}$, then determine the flexibility $\lambda = l_0 / i_{min}$ and check the cross-section. If the condition isn't true the calculations should be repeated having changed the dimensions of steel sheets.

EXAMPLE #2

Choose the cross-section of axially compressed column of continuous cross-section with length l . Loads acting upon the column are equal: constant – G kN, temporary – P kN.

Initial data::

$P=980$ kN;

$Q^H=2400$ kN;

$l=6,8$ m;

Steel grade: 14Г2 ($R_y=240$ MPa);

Restraint conditions variant – a.

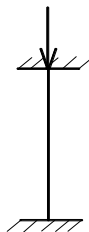

Solution

1. Determine the design strength in column bar:

$$N = G \cdot n_g + P \cdot n_p = 980 \cdot 1.1 + 2400 \cdot 1.2 = 3958 \text{ kH};$$

$$n_g = 1.1; \quad n_p = 1.2;$$

2. Setting-up the cross-section: the column cross-section is taken as the welded one from three steel sheets, for which the radii of inertia can be determined by the approximate formulas:

$$i_x = 0.43 \cdot h; \quad i_y = 0.24 \cdot b;$$

3. Choice of column's cross-section.

Determine the design length of the column:

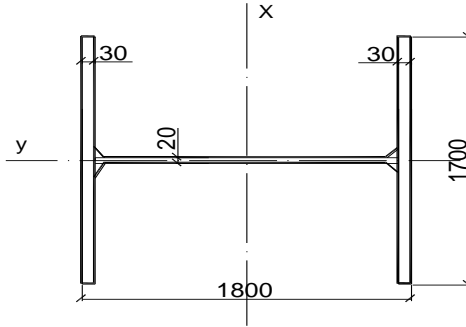

Fig. 5. The accepted column's cross-section for example #2

$$L_0 = \mu \cdot l = 2 \cdot 6.8 = 13.6 \text{ m};$$

Coefficient μ is accepted depending on the restraint conditions for scheme a ($\mu = 2$). By the table 51 of norms 181 $R_y = 310 \text{ MPa} = 3150 \text{ kgf/cm}^2 = 31 \text{ kN/cm}^2$. setting the flexibility in the limits

$\lambda = 60 - 90$, $\lambda_{av} = 75$ depending on the steel brand by the table 72 of appendix 6 (8) determine the value of coefficient φ .

$$\varphi = 0.66; \gamma_c = 1;$$

Determine the cross-section area:

$$\frac{N}{\varphi \cdot A} \leq R_y \cdot \gamma_c; A = \frac{N}{\varphi \cdot R_y \cdot \gamma_c} = \frac{3958}{1 \cdot 0.66 \cdot 31} = 193.5 \text{ cm}^2;$$

The required radius of inertia:

$$i_{req} = \frac{l_0}{\lambda} = \frac{13.6}{75} = 18 \text{ cm};$$

The required width of the cross-section:

$$b_{req} = \frac{i_{req}}{0.24} = \frac{18}{0.24} = 75 \text{ cm};$$

Accept $h = 80 \text{ cm}$

Choose the dimensions of sheets of universal rolled steel by ГОСТ:

$$\delta_f = 3 \text{ cm}; \delta_w = 0.6 \cdot \delta_f = 0.6 \cdot 3 = 1.8 \approx 2 \text{ cm};$$

3.

4. Cross-section verification: $h=80$ cm; $b=75$ cm;

$$\delta_f = 3 \text{ cm}; \delta_w = 2 \text{ cm}; J = \frac{bh^3}{12};$$

$$J_x = 3 \cdot 75 \cdot (40 - 1.5)^2 \cdot 2 + 1 \cdot (40 - 3) \cdot 2 \cdot \left(\frac{40 - 3}{2}\right)^2 \cdot 2 = 717665.5 \text{ cm}^4;$$

$$J_y = 3 \cdot \frac{75}{2} \cdot \left(\frac{75}{4}\right)^2 \cdot 2 \cdot 2 + 1 \cdot (80 - 6) \cdot 0.5^2 \cdot 2 = 158240 \text{ cm}^4.$$

By the smaller radius of inertia determine the minimum radius of inertia:

$$i_{\min} = \sqrt{\frac{J_{\min}}{A}} = \sqrt{\frac{158240}{75 \cdot 3 \cdot 2 + 76 \cdot 2}} = \sqrt{\frac{158240}{1623}} = 16.23 \text{ cm};$$

Determine the elasticity:

$$A = 3 \cdot 75 \cdot 2 + 76 \cdot 2 = 602 \text{ cm}^2$$

$$\lambda = \frac{L_0}{i_{\min}} = \frac{3100}{17.19} = 180;$$

$$\text{Determine the elasticity } \lambda = \frac{l_0}{i_{\min}} = \frac{1360}{16.23} = 84;$$

By the table 72 of the norms /8/ $\varphi=0,57$

Verify the cross-section:

$$\frac{N}{\varphi \cdot A} \leq R_y \cdot Y_c; \frac{3950}{0,57 \cdot 602} = 31 \text{ kH} / \text{cm}^2;$$

$11,5 \text{ kN/cm}^2 < 31 \text{ kN/cm}^2$ – the condition is true, thus general stability is provided.

PROBLEM# 3

Problem task. Verify the cross-section of solid steel upright of rolled section which is acted upon by compressive force N having eccentricity e . The length of the upright is l , the cross-section type, steel brand and restraint conditions are shown in table 3.











THE ORDER OF PROBLEM #3 SOLUTION

1. In the given scale draw the design scheme and cross-section of the upright. For cross-sections of two angles the thickness of joint plate should be set 2 mm greater than that of the flange. According to the table define the design resistance of steel by steel brand.
2. Verify the stability of upright in the plane of moment action according to the formula at $\gamma_c = 0,9$:

$$\frac{N}{\varphi_e A} \leq R_y \gamma_c;$$

Initial data for problem #3

Table 3.

Letter number	Initial data	Surname letters									
		А І,І Т	Б Й У	В К Ф	Г Л Х	Д М Ц	Е Н Ч	Є О Ш	Ж П Щ	З Р Ю	И С Я,Ь
1	N, кN	2500	1050	2000	1800	1500	300	1300	1200	1500	1040
2	e, mm	15	20	16	20	25	15	32	30	40	28
3	l, cm	450	620	600	520	910	450	850	810	720	580
4	Cross-section scheme (the dot shows force application point)										
		60	45	35	55	200x20	40	140x10	50	160x12	40
5	Steel brand	C375	C345	C285	C275	C255	C245	C235	C245	C255	C245
6	Restraint conditions (see. Problem #2)	b	a	c	b	a	b	c	b	a	c

At that it is necessary to take into account that conditional flexibility is defined with respect to the same axis that the eccentricity moment acts.

3. Verify the stability of the upright out of bending plain by the formula:

$$\frac{N}{c\varphi_y A} \leq R_y \gamma_c ;$$

EXAMPLE #3

Verify the cross-section of solid steel upright of steel rolled section, which is acted upon by design compressive force N having the eccentricity e .

Initial data:

$$l = 850\text{cm};$$

$$N = 250\text{kN};$$

$$e = 15\text{mm};$$

$$\gamma_c = 0,9;$$

Restraint conditions variant – b;

Steel brand - *BCm3nc*; $\mu = 1$;

The cross-section type (the dot indicates the force application point) – 2L 200x20.

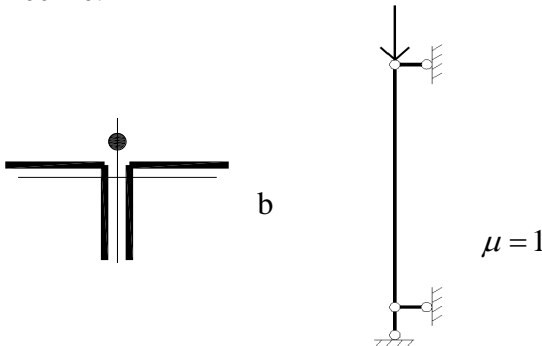

Fig.6. The scheme of cross-section and bar's restraint conditions

Solution

1. Draw the design scheme and the cross-section of the upright.

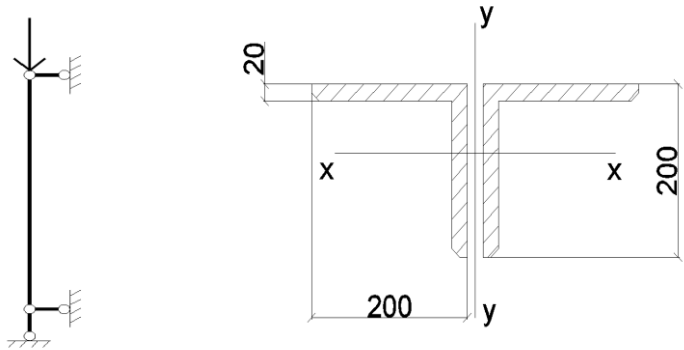

Fig. 7. design scheme and the cross-section of the post

Design resistance of steel by table 51/81:

$$R_y = 235 \text{ MPa} = 23,5 \text{ kN/cm}^2.$$

2. Taking into account $\gamma_c = 0,9$ verify the stability of the upright in the plain of moment's action.

By the assortment: $A = 76,54 \text{ cm}^2$ — the area of one angle.

$$2A = 2 \times 76,54 \text{ cm}^2.$$

$$I_x = 2871,5 \text{ cm}^4, i_x = 6,12 \text{ cm}.$$

Calculate the conditional flexibility. It is defined with the respect of the same axis that the eccentricity moment acts.

$$\frac{N}{\varphi_e A} \leq R_y \gamma_c;$$

Conditional flexibility:

$$\bar{\lambda} = \lambda_{av} \sqrt{\frac{R_y}{E}};$$

$$E = 2,06 \cdot 10^5 \text{ MPa} = 2,06 \cdot 10^4 \text{ kN/cm}^2;$$

$$\bar{\lambda} = \lambda_{cp} \sqrt{\frac{R_y}{E}} = 75 \cdot \sqrt{\frac{23,5 \kappa H / cm^2}{2,06 \cdot 10^4 kN / cm^2}} = 1,9 \approx 2,0;$$

The effective relative eccentricity m_{ef} :

$$m_{ef} = \eta \cdot m ;$$

$$m = \frac{eA}{W_c} ; \quad e = 1,5 cm ;$$

$$W_c = \frac{I_x}{i_x} = \frac{2871,5 cm^4}{6,12 cm} = 469,2 cm^3 ,$$

$$m = \frac{1,5 cm \cdot 2 \cdot 76,54 cm^2}{2 \cdot 469,2 cm^3} = 0,242 ,$$

$$\frac{A_f}{A_w} = 1 - \text{flange and wall cross-section areas.}$$

Out of this we can define the coefficient of cross-section shape influence by the formula:

$$\eta = 1,8 + 0,12m = 1,8 + 0,12 \cdot 0,245 = 1,829 ;$$

$$m_{ef} = \eta \cdot m = 1,829 \cdot 0,245 = 0,448 ;$$

According to the table 74 at the values $\bar{\lambda} = 2,0$, $m_{ef} = 0,448$ we can determine $\varphi_e = 0,67$.

$$\frac{N}{\varphi_e A} \leq R_y \gamma_c ;$$

$$\begin{aligned} \frac{N}{\varphi_e A} &= \frac{300 \kappa H}{0,67 \cdot 2 \cdot 76,54 cm^2} = 2,92 kN / cm^2 \leq R_y \gamma_c = \\ &= 23,5 kN / cm^2 \cdot 0,9 = 21,15 kN / cm^2 \end{aligned}$$

The condition is true

3. According to the formula 56:

$$\frac{N}{c \varphi_y A} \leq R_y \gamma_c ;$$

As $m_x < 5$:

$$c = \frac{\beta}{1 + \alpha m_x}; \quad \alpha = 1, \quad \beta = 0,7, \quad c = \frac{0,7}{1 + 1 \cdot 0,245} = 0,56;$$

$$\frac{N}{c \varphi_y A} = \frac{300 \text{ kN}}{0,56 \cdot 0,67 \cdot 2 \cdot 76,54 \text{ cm}^2} =$$

$$5,22 \text{ kN/cm}^2 < R_y \gamma_c = 23,5 \text{ kH/cm}^2 \cdot 0,9 = 21,15 \text{ kN/cm}^2.$$

The cross-section of steel upright is verified.

PROBLEM #4

Problem task. Choose the cross-section of steel axially tensile bar of rafter truss of coupled equal-flange angles. The design stress in the bar is N. calculate and construct the fastening of angles with the knot joint plate by side-lap welds (table 4).

PROBLEM #4 SOLUTION ORDER

1. Having determined by table 1 of app. 1 the design resistance of steel, on the base of formula $N/A_n \leq R_y \gamma_c$ determine the required area of two rolled angles A_n .
2. By the assortment of equal-flange angles (ГОСТ 8509) choose two rolled angles of general area not less than the required one.
3. In the scale accepted draw the knot designed in two projections. The thickness of joint plate should be taken 2 mm greater than that of the angles chosen.
4. Design the fastening of angles to the joint plate. Perform the fastening of angles to the joint plate by manual welding by means of jump-welding method. The dimensions of welds are calculated by the formulas. It is recommended first to set the dimension of weld leg k_f in the following limits: for leaf k_f is accepted from 4 mm to t_{min} ; for back – from 6 mm to $1,2t_{min}$ (here t_{min} – the minimum thickness of elements to be jointed). The designation of leaf and back is shown on the scheme (Fig.8.)

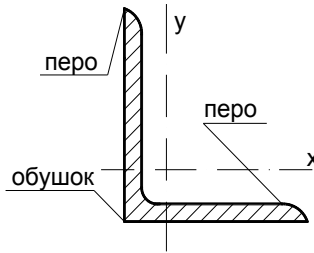

Fig.8 Rolled angle cross-section

Initial data for problem #4

Table 4

Letter number	Initial data	Surname letters									
		А И,Ї Т	Б Й У	В К Ф	Г Л Х	Д М Ц	Е Н Ч	Є О Ш	Ж П Щ	З Р Ю	И С Я,Ь
1	N, kN	340	450	800	1020	1140	1520	1600	1820	2400	2750
2	Steel brand	C235			C245			C255		C275	

After that for the calculation by weld material the required length of weld is determined for leaf

$$l_l = \frac{N_n}{R_{wf} \gamma_{wf} \gamma_c \beta_f k_f n_w}, \text{ and for back } l_b = \frac{N_{o\sigma}}{R_{wf} \gamma_{wf} \gamma_c \beta_f k_f n_w}$$

Here $N_l=0,3N$; $N_b=0,7N$; the number of welds per knot is $n_w=2$; k_f is set primarily; the rest of the values are taken according to item (13).

By the analogical way on the base of the formula the length of weld by fusion limit is calculated. Accept the maximum length of weld rounding to 10 mm.

EXAMPLE #4

Choose the cross-section of centrally tensile bar of rafter truss of coupled equal-flange angles. The design stress in the bar is N . calculate and construct the fastening of angles to joint plate by side-lap.

Initial data:

1. Design force – $N = 1520kN$.
2. Steel brand 15XCHД.

Solution

1. Determine by the table 51(app.1./8/) design resistance of steel. Determine the required area of two rolled angles A_n :

$$R_y = 310MPa = 31,0kN/cm^2$$

$$\frac{N}{A_n} \leq R_y \cdot \gamma_c, \quad \gamma_c = 0.95 \text{ by the table 6 of the norms}$$

$$A_n = \frac{N}{R_y \cdot \gamma_c} = \frac{1520kN}{31kN/cm^2 \cdot 0.95} = 51,6cm^2.$$

2. By the assortment of equal-flange angles (ГОСТ 8509) choose two rolled angles, the total area of which is equal or greater than the required one. Accept rolled angle:

$$\text{№}12,5 (125 \times 12; A_{n1} = 28,89cm^2; A_n = 2A_{n1} = 57,78cm^2)$$

3. Draw the designed knot in two projections. The thickness of joint plate is taken 2 mm thicker than that of the thickness of the angle: $\delta = 12 + 2 = 14mm$.

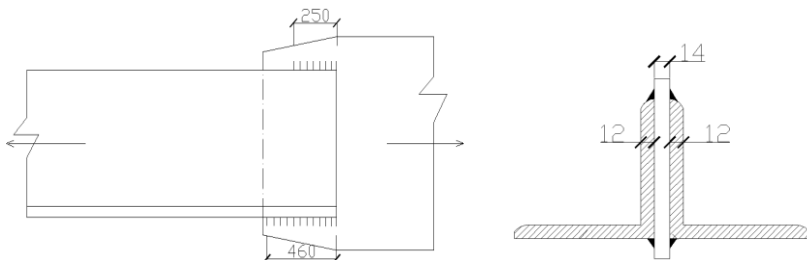

Fig. 9. Welding junction of angles with joint plate

4. Calculate the fastening of angles to the joint plate. The fastening is performed by means of manual welding by jump-welding method. Weld dimensions are determined by the formulas:

$$\frac{N}{\beta_f k_f l_w} \leq R_{wf} \gamma_{wf} \gamma_c - \text{by the weld metal}$$

$$\frac{N}{\beta_z k_f l_w} \leq R_{wz} \gamma_{wz} \gamma_c - \text{by the fusion limit (fig.10)}$$

Set the dimensions of weld leg k_f in the limits:

– for leaf $k_f = \text{from } 4 \text{ to } \delta_{\min} = 4 - 12 \text{ mm} \approx 8 \text{ mm}$;

– for back $k_f = \text{from } 6 \text{ to } 1.2 \delta_{\min} = 6 - 14,4 = 10 \text{ mm}$.

δ_{\min} – the minimum thickness of the elements jointed

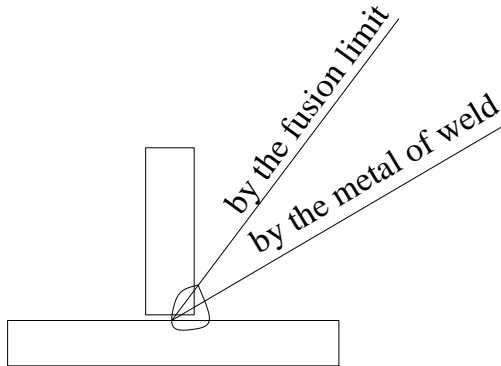

Fig.10. Design cross-sections at jump-welding method
By the metal of weld determine the design length of the weld:

For leaf:

$$l_l = \frac{N_l}{R_{wf} \gamma_{wf} \gamma_c \beta_f k_f n_w}; \quad N_l = 0,3N; \quad k_f = 0,8 \text{ cm}; \quad n_w = 2;$$

$$R_{wf} = \frac{0,55 R_{wun}}{\gamma_{wm}} = \frac{0,55 \cdot 410 \text{ MPa}}{1,25} = 180,4 \text{ MPa} = 18,04 \text{ kH} / \text{cm}^2;$$

The coefficient of weld work conditions: $\gamma_{wf} = 1$;

General work conditions coefficient: $\gamma_{wf} = 0,95$;

Coefficient β_f according to table 34, $\beta_f = 0,7$

$$l_l = (1520 \cdot 30) / (18,04 \cdot 1 \cdot 0,95 \cdot 0,7 \cdot 0,8 \cdot 2) = 23,8 \text{ cm} \approx 24 \text{ cm} .$$

For back:

$$l_b = \frac{N_b}{R_{wf} \gamma_{wf} \gamma_c \beta_f k_f n_w} ;$$

$$N_b = 0,7N ;$$

$$k_f = 1 \text{ cm} ; n_w = 2 ; \gamma_{wf} = 1 ; \gamma_c = 0,95 ; \beta_f = 0,7 ;$$

$$R_{wf} = 18,04 \text{ kN/cm}^2 ;$$

$$l_b = (1520 \cdot 0,7) / (18,04 \cdot 1 \cdot 0,95 \cdot 0,7 \cdot 1 \cdot 2) = 44,4 \text{ cm} \approx 45 \text{ cm} .$$

By the calculation by the fusion limit analogically determine the length of weld:

For leaf:

$$l_l = \frac{N_l}{R_{wz} \gamma_{wz} \gamma_c \beta_z k_f n_w} ;$$

$$N_l = 0,3N ;$$

By the table 3. /8/ $R_{wz} = 0,45R_{un}$

R_{un} – tensile strength of steel

By the table 51 of the norms /8/

$$R_{un} = 450 \text{ MPa} = 45 \text{ kN/cm}^2$$

$$R_{wz} = 0,45R_{un} = 0,45 \cdot 45 = 20,25 \text{ kN/cm}^2$$

The coefficient of weld's work conditions:

$$\gamma_{wz} = 1 ;$$

$$l_l = (1520 \cdot 0,3) / (20,25 \cdot 1 \cdot 0,95 \cdot 1 \cdot 0,8 \cdot 2) = 14,8 \text{ cm} \approx 15 \text{ cm} .$$

For back:

$$l_b = \frac{N_b}{R_{wz} \gamma_{wz} \gamma_c \beta_z k_f n_w} ;$$

$$N_b = 0,7N ;$$

$$k_f = 0,8 \text{ cm} ; n_w = 2 ; \gamma_{wz} = 1 ; \gamma_c = 0,95 ; \beta_z = 1 ;$$

$$R_{wz} = 20,25 \text{ kN/cm}^2 ;$$

$$l_b = (1520 \cdot 0,7) / (20,25 \cdot 1 \cdot 0,95 \cdot 1 \cdot 1 \cdot 2) = 27,7 \text{ cm} \approx 28 \text{ cm} .$$

Accept the maximum length of weld:

$$l_l = 24\text{cm} + 1 = 25\text{cm} ,$$

$$l_b = 45\text{cm} + 1 = 46\text{cm} .$$

1 cm is added for the reason of skin weld on both ends of it, thus 0,5 cm from both sides.

PROBLEM #5

Problem task. Design the junction of two steel sheets of bxt cross-section. The junction is acted upon by tensile force N . Steel brand of sheets and bolt types are given in table 5.

PROBLEM #5 SOLUTION ORDER

1. Design the junction as a symmetrical one, on two cover plates conditioned that their total thickness was 2-4 mm greater than that of the sheets jointed. Draw the junction in a scale in two projections.

2. Depending on the bolt type determine it's bearing capacity by the formulas:

– For shearing strain $N_b = R_{bs}\gamma_b A_{ns}$;

– For bearing strain $N_b = R_{bp}\gamma_b d \sum t$;

– For tensile strain $N_b = R_{bt}A_{bn}$;

Determine the required number of bolts for one half of the junction.

Use the formula: $n \geq N / (\gamma_c N_{min})$

3. Check the bearing capacity of the sheets, weakened by the

apertures for bolts by the formula $\frac{N}{A_n} \leq R_y \cdot \gamma_c$

4. Junction construction. Bolt diameter is accepted by the construction possibilities choosing from the following variants: 12, 14, 16, 18, 20, 22, 24, 27, 30 mm. Bolts are to be located in row or staggered order. The minimum distance between the bolt centers is: along and across the force action direction - 2.5d, the maximum one – 8d in outer rows, and 16d in interior rows. The minimum distance from

the center of the bolt to the element's edge is: along the force action direction – $2d$, across the force action direction – $1.5d$; the minimum distance for high-strength bolts in any direction – $1.3d$.

Initial data for problem #5

Table 5

Letter number	Initial data	Surname letters									
		А І,І Т	Б Й У	В К Ф	Г Л Х	Д М Ц	Е Н Ч	Є О Ш	Ж П Щ	З Р Ю	И С Я,Ь
1	bxt, mm	400x8	420x8	450x10	480x10	560x14	600x16	500x12	530x12	630x18	650x20
2	Steel brand	C235		C245		C255		C275		C285	
3	N, kN	520	576	760	810	925	1020	980	1010	970	940
4	Bolt type	Precision bolt		40X «селект»		Precision bolt		30x3M9		Precision bolt	
5	Accuracy class	A	B	C	B	C	A	B	B	C	A
6	Strength grade	4,6	4,8	5,6	4,6	4,8	4,5	4,6	5,8	4,8	4,6
7	Processing technique	Дробометальный without conservation		No processing		Дробометальный with conservation		With steel brushes		No processing	

When applying staggered order the distance between bolt centers along the force action direction should not be less than $a+1.5d$, here a is the distance between the bolt rows across the force action direction.

EXAMPLE #5

Design the junction of steel sheets of cross-section $b \times t$, acted upon by tensile force N

Initial data:

$b \times t = 600 \times 16 \text{ mm}$; Steel brand: 15XCHД; $N = 1025 \text{ kN}$;

Bolt type — precision bolt, strength grade – 4.8, not sheets surface processing is foreseen.

Solution

1. Design the junction symmetrically on two cover plates at the condition that their total thickness was 2-4 mm greater than that of sheet junction: $\delta_1 = 10 + 10 = 20 > 16 \text{ mm}$

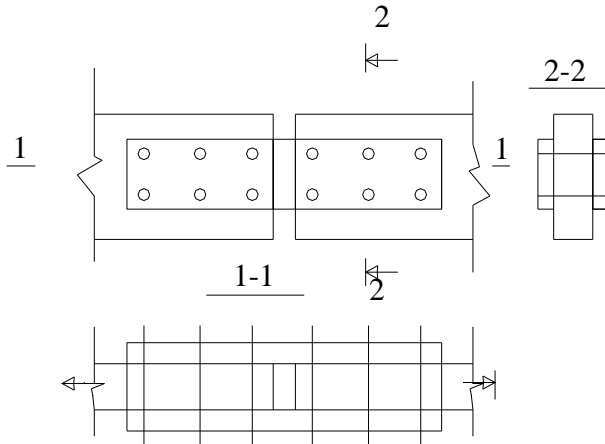

Fig.11 The scheme of bolt junction

2. Depending on the bolt type its bearing capacity is defined.

According to СНиП for steel brand – 15XCHД

$$R_y = 330 \text{ MPa} = 33 \text{ kN/cm}^2$$

We'll check this bolt for shearing strain, tensile strain and bearing strain:

- For shearing strain $R_{bs} = 160 \text{ MPa} = 16 \text{ kN/cm}^2$;
- For tensile strain $R_{bt} = 160 \text{ MPa} = 16 \text{ kN/cm}^2$;

- For bearing strain $R_{ep} = 330MPa = 33.5kH / cm^2$.

3. Check for the shearing strain:

$$N_b = R_{bs} \cdot \gamma_b \cdot A \cdot n_s,$$

where $\gamma_b = 0,9$ — junction coefficient of work conditions (table 35 in the norms /8/)

Bolt's cross-section area:

$$A = \frac{\pi \cdot d^2}{4} = \frac{3,14 \cdot 3,0^2}{4} = 7.06cm^2 \quad (\text{by the table 62 of the norms})$$

By the table accept $d = 30 \text{ mm}$ $A_b = 7,06cm^2$, $A_{bn} = 5,6cm^2$ from the list of bolts: 12, 14, 16, 18, 20, 22, 24, 27, 30 mm. $n_s=2$ — the number of design cuts of one bolt.

Then,

$$N_b = R_{bs} \cdot \gamma_b \cdot A \cdot n_s = 16kN/cm^2 \cdot 0,9 \cdot 7.06cm^2 \cdot 2 = 203.3kN.$$

4. Check for bearing strain:

$$N_b = R_{bp} \cdot \gamma_b \cdot d \cdot \sum t,$$

Where $\sum t = 10 + 16 + 10 = 36mm = 3,6cm$

$$N_b = R_{bp} \cdot \gamma_b \cdot d \cdot \sum t = 33,5 \cdot 0,9 \cdot 3,0 \cdot 3,6 = 325.6kN.$$

5. Check for tensile strain:

$$N_b = R_{bt} \cdot A_{bn} = 16 \cdot 5.6 = 89.6kN;$$

$$A_{bn} = 5.6cm^2; d = 30mm;$$

For further calculations accept the smallest value (namely the one for tensile strain) $N_b = 89.6kN$.

The required number of bolts taking into account $\gamma_c = 1,05$:

$$n \geq \frac{N}{\gamma_c \cdot N_{\min}} = \frac{1025kN}{1,05 \cdot 89.6kN} = 10.89 \approx 12 \text{ bolts}$$

6. Check the bearing capacity of the sheets weakened by the apertures for bolts:

$$\frac{N}{A_n} \leq R_y \cdot \gamma_c \quad (\text{formula 5 of the norms})$$

$$b = 60 - 3 \cdot 3 = 51 \text{ cm}, \delta = 1,6 \text{ cm}; (51 \times 1.6) \text{ cm};$$

$$b = 60 - 3 \cdot 3 = 51 \text{ cm}, \delta = 1,2 \text{ cm}; (51 \times 1.2) \text{ cm};$$

$$\frac{1025}{51 \cdot 1.6} = 12.8 < 33 \cdot 0,9 = 29,7 \text{ kH} / \text{cm}^2$$

$$\frac{1025}{51 \cdot 1.2} = 16.7 < 29,7 \text{ kH} / \text{cm}^2; \text{ Condition is fulfilled.}$$

7. Construction of the junction:

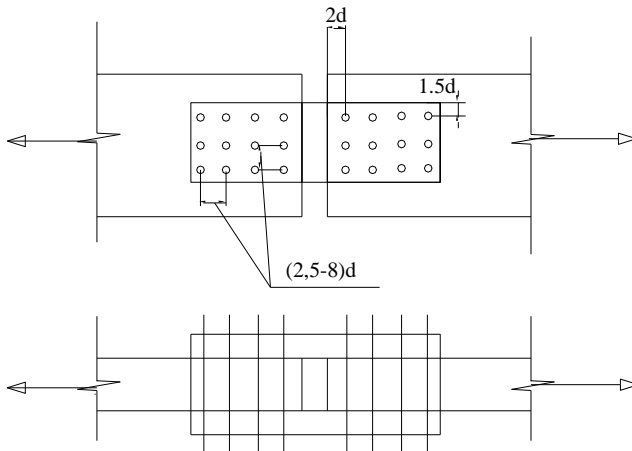

Fig.12. Desing of bolt junction

PROBLEM #6

Problem task. Choose the cross-section of a glued bead of constant depth for covering of warehouse building of span l . The design uniformly distributed load on the beam is $-q$, the basic load $-0.85q$. the allowed relative sag $[f/l]=1/200$. the initial data is given in table 6.

Initial data for problem #6

Table 6.

Letter number	Initial data	Surname letters									
		А І,І Т	Б Й У	В К Ф	Г Л Х	Д М Ц	Е Н Ч	Є О Ш	Ж П Щ	З Р Ю	И С Я,Б
1	l, m	6	6.5	7.0	7.6	8.0	9.0	9.4	10.0	10.6	12.0
2	q, kN/m	18.0	17.1	16.0	14.3	13.1	15.1	10.2	12.0	11.2	10.0

PROBLEM #6 SOLUTION ORDER

1. Accept the cross-section of the beam made of boards of rectangular cross-section of width $b \leq 17 \text{ cm}$ and $b \geq h/6$. The cross-section depth should be defined by the calculation. It should be in eh limits $(1/10 \dots 1/15)l$ considering the thickness of dressed boards δ (2 mm of board's thickness from each side is spent for dressing). It is recommended to take boards of thickness 16, 19, 25, 32, 40, 50 mm and width 100 – 170 mm.

2. Define the bending moment $M = \frac{q \cdot l^2}{8}$.

3. Define the required moment of inertia $W_{req} = \frac{M}{R_u}$.

4. At the set width b of the board the depth of cross-section is

$$\text{equal } h = \sqrt{\frac{6W_{req}}{b}}$$

Taking into account the thickness of dressed board b and the cross-section depth h , define the required number of boards in the cross-

$$\text{section } n = \frac{h}{\delta}.$$

Calculate the relative sag of the beam $\frac{f}{l} = \frac{5 \cdot q^4 \cdot l^3}{384 \cdot EI}$ and compare it

to the allowed one.

5. Check the strength by the formula:

$$\frac{M}{W_p} \leq R_u,$$

here M – the design bending moment;

W_p – the design moment of resistance, which for composite elements is $W_p = W_{um} \cdot k_w$, where $k_w < 1,0$

Precise the cross-section dimensions if necessary.

6. Calculate the relative sag of the beam $\frac{f}{l} = \frac{5 \cdot q^b \cdot l^3}{384 \cdot EI}$ and

compare it to the allowed one.

7. Construct the cross-section of the beam in the manner that the wood of second type was located in the edge portions of the cross section ($0,17h$ from both sides), and the rest of the cross-section was constructed of the third type wood at the condition that $h < 50$ cm. At $h > 50$ cm additionally for outer tensile zone the wood of the first type should be used. Draw the cross-section in a scale.

EXAMPLE #6

Choose the cross-section of a glued bar to cover a building of span l . Design uniformly distributed load is q ; the basic load is

$$q^b = 0.85q. \text{ The allowed relative sag of the beam } \left[\frac{f}{l} \right] = \frac{1}{300}.$$

Initial data:

1. Design uniformly distributed load is $q = 15,2kN/m$;
2. The span length is $l = 9,0m$;
3. The basic load $q^b = 8,4kN/m$;
4. The allowed relative sag of the beam $\left[\frac{f}{l} \right] = \frac{1}{300}$.

Solution:

1. Determine:

$$h = [(1/10) - (1/15)] \cdot l = (900/10) \cdot l - (900/15) \cdot l = 90 - 60 \text{ cm};$$

$$\delta = 32 - 2 \cdot 2 = 28 \text{ mm} = 2.8 \text{ cm};$$

$b \geq h/6 = 70/6 = 11,7 \text{ cm}$. Taking into account the design experience we accept $b = 10 \dots 17 \text{ cm}$, accept $b = 15 \text{ cm}$.

2. Design bending moment:

$$M = \frac{ql^2}{8} = \frac{15,2 \text{ kN/m} \cdot (9 \text{ m})^2}{8} = 154 \text{ kNm}.$$

3. The required moment of resistance:

$$\frac{M}{W} \leq R_u; \quad W_{req} = M / R_u; \quad R_u = 13 \text{ MPa};$$

$$W_{req} = M / R_u = \frac{154 \cdot 100 \text{ kN/cm}}{1.3 \text{ kN/cm}^2} = 11830 \text{ cm}^3.$$

4. Precise the cross-section depth:

$$h = \sqrt{\frac{6W_{req}}{b}} = \sqrt{\frac{6 \cdot 11830 \text{ cm}^3}{15 \text{ cm}}} = 69 \text{ cm}; \quad h = 70 \text{ cm};$$

Determine the required number of boards:

$$n = \frac{h}{\delta} = \frac{70}{2,8} = 25 \text{ boards}$$

1. Check by the second group of limit states, by the rigidity:

$$E = 10000 \text{ MPa};$$

$$\frac{f}{l} = \frac{5q^b l^3}{384EI} = \frac{5 \cdot 8,4 \text{ kN/m} \cdot 9^3 \text{ m}^3}{384 \cdot 10000 \text{ MPa} \cdot 429 \cdot 1000 \text{ cm}^4} = \frac{1}{540} < \frac{1}{300},$$

$$I = \frac{bh^3}{12} = \frac{15 \cdot 70^3}{12} = 429 \cdot 1000 \text{ cm}^4.$$

The condition is true. Thus, beam's rigidity is provided.

2. Construct the cross-section:

$$0.15h = 0.15 \cdot 70 = 10,5 / 2,8 \approx 4 \text{ boards (1}^{st} \text{ type)};$$

$0.17h = 0.17 \cdot 70 = 11,9 / 2,8 = 4 \text{ board (2}^{nd} \text{ type)}$; all other boards are of the 3rd type of wood.

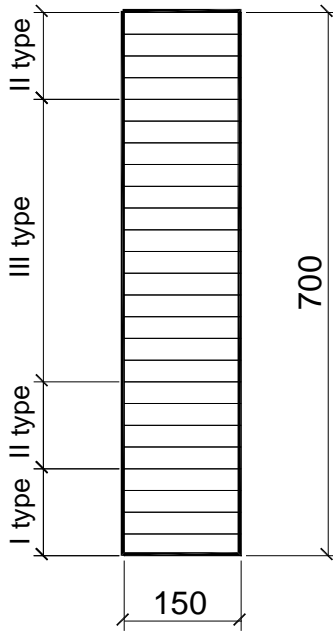

Fig.14. Construction of the wooden beam.

LITERATURE

1. МЕТАЛЛИЧЕСКИЕ конструкции / Под ред. Е.Н. Беленя.- М. : Стройиздат, 1986. -560с.
2. СТРОИТЕЛЬНЫЕ конструкции / Под ред. В.Н. Байкова, Г.И. Попова -М.: Высш. шк. 1986. -543с.
3. МАНДРИКОВ А.П. Примеры расчета металлических конструкций. - М. : Стройиздат, 1991. -431с.
4. АЛЮМИНИЕВЫЕ конструкции: Справочное пособие.- М. : Стройиздат, 1978. -145с.
5. ГРИНЬ И.М., ДЖАН-ТЕМИРОВ К.Е., ГРИНЬ В.И. Строительные конструкции из дерева и синтетических материалов.-К. :Вища шк. 1990. -221с.
6. ЗУБАРЕВ Г.Н., ЛЯЛИН И.М. Конструкции из дерева и пластмасс.-М.: Высш. шк. 1980. -311с.
7. СНиП П-25-80. Деревянные конструкции. Нормы проектирования / Госстрой СССР.-М.: Стройиздат, 1983. - 31с.
8. СНиП П-23-81*. Стальные конструкции. Нормы проектирования / Госстрой СССР. -М.: ЦИТП Госстроя СССР, 1991. -96с.
9. СНиП 2.01.07-85. Нагрузки и воздействия. Нормы проектирования / Госстрой СССР. -М.: ЦИТП Госстроя СССР, 1987. -36с.
10. СНиП 2.03.06-85. Алюминиевые конструкции. Нормы проектирования / Госстрой СССР. -М.: ЦИТП Госстроя СССР, 1986. -48с.
11. Строительные конструкции : Методические указания и контрольные задания. Манько А.В. -К.: КИИГА. 1989. - 44с.
12. Будівельні конструкції : Методичні вказівки і контрольні завдання. Манько А.В. -К.: КМУЦА. 1996. -44с.

THE BASIC LETTER DESIGNATIONS

- A – gross cross-section area;
 A_n – net cross-section area;
 A_d – diagonal brace cross-section area;
 A_f – flange cross-section area (f from flange);
 A_{wf} – cross-section area along the metal of fillet weld (w from welding, f from fillet);
 A_{wz} – welding zone cross-section area (w from welding, z from zone);
 E – elasticity modulus;
 F – force (concentrated);
 v – uniformly distributed load;
 g – uniformly distributed dead load;
 N – longitudinal force;
 Q – transverse shearing force;
 Q_{fic} – conditional transverse force for elements in junction (fic from fiction);
 Q_s – conditional transverse force for one side of slat (s from slat);
 M – bending moment;
 R_y – design resistance to tension, compression or bending by the yield limit;
 R_u – design resistance to tension, compression or bending by the ultimate resistance;
 R_p – design collapse resistance of an end at the presence of fitting (p from plumb);
 R_s – design resistance of steel to shear strain (s from shear);
 R_{bs} – design shear resistance of bolt (b from bolt, s from shear);
 R_{bp} – design bearing strain of bolt junctions (b from bolt, p from plumb);
 R_{bh} – design resistance of high-strength bolts to tension (b from bolt, h from high-strength);
 R_{wf} – design resistance of fillet welds to conditional shear (w from welding, f from fillet);
 R_{wz} – the same by the fusion limit (w from welding, z from zone);
 R_{wy} – design resistance of weld junction to tension, compression and bending by the yield limit (w from welding, y from yield);
 b – width;

b_f – flange width (f from flange);
 b_{ef} – effective flange width (ef from effective);
 b_h – the width of rib extension (h from hammer);
 h – height (depth);
 h_{ef} – effective wall height (ef from effective);
 l – length, span;
 l_c – the length of upright, column (c from column);
 l_{ef} – effective length (ef from effective);
 l_m – length of panel of a truss, upright;
 l_s – slat length (s from slat);
 l_w – weld length (w from welding);
 t – thickness;
 t_f – flange thickness (f from flange);
 t_w – wall thickness (w from wall);
 k_f – the height of fillet weld leg (f from fillet);
 I – moment of inertia;
 W – moment of resistance;
 S – static moment;
 i – radius of inertia of a cross-section;
 r – radius;
 e – absolute eccentricity;
 m – relative eccentricity ($m=A/W_e$);
 m_{ef} – effective eccentricity $m_{ef}=\eta m$ (ef from effective);
 η – the coefficient of cross-section shape influence;
 λ – flexibility ($\lambda =l_{ef}/l$);
 $\bar{\lambda}$ – conditional flexibility ($\bar{\lambda} = \lambda\sqrt{R_y/E}$);
 λ_{ef} – effective flexibility of a bar of solid cross-section (ef from effective);
 $\bar{\lambda}_w$ – conditional flexibility of beam's wall $\bar{\lambda}_w = \frac{h}{t}\sqrt{R_y/E}$ (w from wall);
 σ – normal stress;
 σ_{loc} – local stress (loc from local);
 τ – shearing (tangential) stress;
 φ – buckling coefficient;

- φ_e - coefficient of design resistance reducing due to eccentric compression (e from eccentric);
- φ_b - coefficient of design resistance reducing due to torsion-bending form of stability loss (b from bending);
- β_f, β_z - coefficients of welding for fillet weld calculation by the metal of weld and by the fusion limit (f from fillet, z from zone).