

# Modelling of “Human-Environment” system on the theory of S- space self-organization foundation

V.Y. Mikhailenko, Dr. Sc., Prof., N.I. Sedletskaia, Dr. Phil., Prof., Y.N. Kovaluov, Dr. Sc.

## Abstract

Axioms of S- space, theory of S- space self-organization, S- mappings are described. The general model “human-environment” and some of working models, which illustrated practice of its application, are considered. A demonstration version of COMP- 97 software is described.

*Key words:* ecology, geometry modelling, wave model of S- space, theory of self-organization, environment, human factor.

## Introduction

Human interactions with environment are complex and include the physical, chemical, biological, psychological and other qualitatively heterogeneous factors. Therefore “human-environment” model is to be built on the base of a system approach and to be in accord with properties of complicated systems: emergency, opening, self-organization with gradual changes accumulation and qualitative transitions; heterogeneous, incommensurable, components; synergy, non-linear, with presence of doorstep effect interactions. Comparison of these properties with the properties of geometrical spaces and transformations reveals their disparity on level of axiomatic determinations. So, is necessary to construct the adequate geometrical vehicle within the framework paradigm, that includes the research methods, axioms, theory of self-organization, mappings, models, practical application receptions. Such vehicle was created [1, 2], and some results are given below.

## Basic Models

*Axiomatic wave model of S- space* include 17 axioms, disjointed on 4 groups. The *axioms of existence* (1.1-1.5) establish the modalities ratio of existence (A, P) of S-space (Sp), sets and elements, rules of their mutual transition, depending on effects of the external subject (Sb) and object (Ob). Elements are the waves and solitons – abstraction of the conforming physical objects. The axioms 1.1-1.5 have the highest priority. The *axiom of a condition* (2.1) determines the connection of S- space, sets and elements on macro and microlevels as a relation of a condition modality of elements from a course of evolution of Sp, and on the contrary, relation of a directivity of space changes to modality of an elements condition. The priority is lower, than for the axioms of the maiden group. The *axioms of interactions* (3.1-3.9) characterize conditions of interaction of Sp components and existence or absence of return operations; they are applied only together with the axioms 1.1-2.1. The *operations* are abstraction of different kinds of interactions of physical surges (superposition, coincidence, interference, diffraction); they are elementary and are irresolvable on more simple. The *axioms of measurement* (4.1-4.2) establish procedures of interaction with a coordinate system for waves and solitons. The measurements are characterized: by incommensurability of the characteristics of miscellaneous levels of organization; by a state transition coordinate system and measured element; by miscellaneous outcomes of repeated measurements; by miscellaneous outcomes of measurement of a element in miscellaneous coordinate system. The model satisfying 1.1-4.2, is called the *wave model* of S-space.

The *theory of self-organizing* limits the ways of S-sets formation, come from a symmetry Sb and Ob rather Sp and integrity of the universe. It results in a skew-symmetry Sp and necessity of a harmonic ratio of the homogeneous characteristics of current stage of stratification to the characte-

ristics of the previous stage with a factor of “golden section”. Let's put some predictions for the script (1Sb, 1Ob).

1. Number  $n$  of elements, depending on a stage of stratification  $m$ :

$$n \approx \frac{1}{\sqrt{5}} ((\Phi + 1)^m - (-\Phi - 1)^{-m}), \quad (1)$$

i.e. is expressed by the Fibonacci numbers (1, 1, 2, 3, 5, 8, 13, 21...).

2. At stratification S-set with a potential  $\pi$  (intuitive characteristic of the ability to interactions; is expressed in conventional units), the potential  $\pi_n$  is transmitted to each element:

$$\pi_n = \frac{\pi\Phi}{n}, \quad (2)$$

where  $n$ - an index of a current layer.

As the potential  $Sp$  is not equal to the sum of potentials of the components of elements, bound with characteristics of any layer are heterogeneous to the characteristics of the subsequent and the previous layers. Therefore Shannon estimation of an information quantity should be conducted for each layer separately.

4. Wavelength  $l_k$  of a current layer in relation to a wavelength of the previous layer is determined under the formula

$$l_k = \frac{l_{k-1}}{2n}, \quad (3)$$

where  $k$ - number of a current layer.

The connection of a wave potential with length  $l$  and amplitude  $A$  expresses

$$\pi = f(l/2, A), \quad (4)$$

where  $f$ - a function of proportionality.

Estimation of a potential of a wave is the value of a potential of her half.

6. As a unit of measurement of time  $t$  its period is adopted. Each layer has  $t_k$ , i.e. the time for  $Sp$  is characterized by a “boom of time” and stratification. The scripts of stratification and *convolution* (process, return stratification), for which one a life time of each layer expressed in relative units is identical.

7. A stratification – convolution act according to the scripts instituted by the environmental conditions (quantity Sb and Ob, degree of potential losses compensation) to formation parallel, perpendicular, or and those, and other elements. Number of groups and the degrees of symmetry of each layer determine the proving proposals. The connection of conservation laws and symmetry groups is similar by the Noether theorem.

8. The conditions indispensable for implementation of operations, their particular cases, list of the measured characteristics and procedure of selection coordinate system are described in [1].

9. The system of the axioms is full and is consistent in the sense that the conducted researches do not demand the introducing of padding rules and do not reveal inconsistencies between the axioms of miscellaneous groups.

*Transition to graphic object models.* For miscellaneous needs are indispensable not everything, but only some characteristics of wave model. Therefore it is expedient to esteem the regularity of self-organizing as a set of invariants, and, approximately expressing specific S-transformations by sequences of topological and projective mappings to pass from wave model to homomorphic *graphic object models* by the way S-graphs and PC-charts. The theory of invariants is constructed; the mappings and models are accordingly categorized. The design concepts and conditions of applicability of mappings are determined. The ways of conditional values binding to physical units of

measurements and their graphic expression – metrization of the graphs and charts are designed. *The construction sequence of graphs and charts* such: 1) determination of  $E^n$  dimension; 2) abstraction from wave model with view of to imagine her in S-graph appearance into  $E^n$ , so, that were well-kept invariants; 3) topological transformations curves into pieces straight with the matter of simplification of graphic image; 4) using of local involute for simplification of projection; 5) image construction; 6) metrization; 7) addition graphic model by comments.

### Human – Environment Model (HEM)

Analysis of factual data gives rise to deduction, that the most general organization case has a place – Sp forms as the result of {Sb} and {Ob} interactions.

The simplest way of S-space self-organization models by graph shown on Fig.1, which reflects general system construction principles (some details not shown). Determine:

- Organization levels, sequence and priorities of their beginnings and their correspondence with psychic, physical, physiological and anatomic structures;
- Weighting coefficients for each level (proportional to potentials);
- Number of elements of each level and amount of independent descriptions (derivative Fibonacci numbers);
- Description changes scopes not conducting to violation system organization (from non-admission condition further stratification – convolution);
- Exchange mechanisms between elements and levels (from symmetry conditions and keeping laws). On Fig.1 shown, what exchanges (marked by pointers) occur because of a damage of the element, marked by circle. The phenomena of compensation, regeneration, homeostasis preservation are described in sickly way.

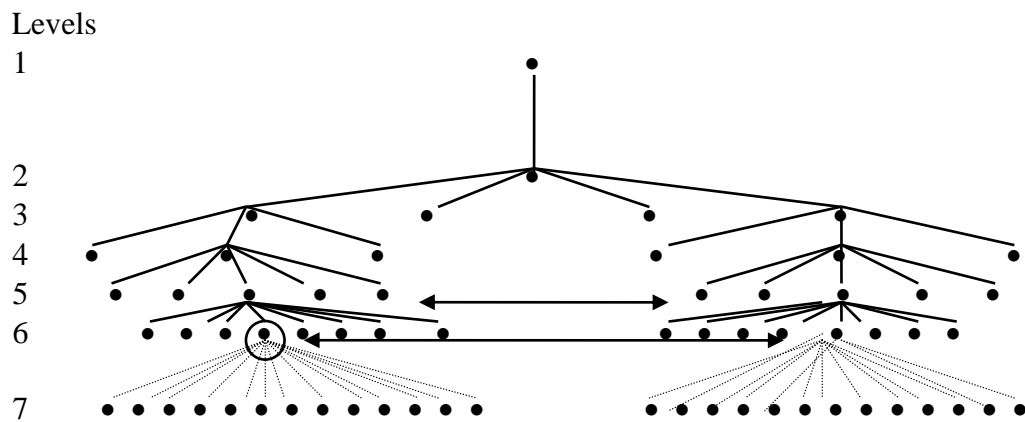

Fig. 1. Organization and interactions in “human-environment” system

### 3. Working Models and Practical Uses

The examples of using The HEM are giving below.

*Perception Model (PM)*. The connection to HEM levels and rhythms of cerebrum is directed into table 1. Estimation of relative weight of different perception appearances  $p$ , which takes into account are determine: action domain for potentials sum of involved levels; perception appearance meaningfulness for professional activity ( $k_1$ ); perception conditions ( $k_2$ ); correspondence with recognition and making decision:

$$p = \frac{\sum_{j=i_1}^{i_n} \pi_j \cdot k_1 \cdot k_2}{i_i - i_n + 1} \quad (5)$$

From computations swim out the practical recommendations, for example, as for *guaranteeing of information reverberation systems reliability*:

- Given about equipment work present in form, comfortable for intuitive perception;
- The visual data use to managing method emotional operator state and tuning maintenance on intuitive perception;
- Sound accompaniment duplicates, and attached to necessity and reinforces an emotional tuning; it is must not create the impediments for negotiations.

Such reverberation system offered to name *intuitive*.

**Table 1.**

*Perception appearances correlations.*

№ of level	Number of elements	Article of perception	Perception	Psychic states	Rhythm brain
1	1	“human-environment” system integrity	intuitive	broadened consciousness	unknown
2	1	integrity of organized structure on unorganized background	intuitive	rest, sleep without dreams	$\Delta$ , 0,5-4 Hz
3	2	binary self-discipline estimation well, badly, etc.	plus emotional	rest, superficial sleep	$\Theta$ , 4-7 Hz
4	3	threefold stratification in space-time.	plus intellectual	vigil	$\alpha$ , 8-13 Hz
5	5	sensory irritants: lightly, sound and etc.; equilibrium sense; tiredness, hunger and etc.	plus receptors (3 groups)	sensory perception; mental work	$\beta$ , 14-35 Hz
6	8	main colors, sounds and etc.; equilibrium gradations; tiredness and etc.	that	excitation	$\gamma$ , 34-55 Hz
7	13	color gradations, sound etc.	that	that	that

The following tasks can be coped with: 1) Determination of amount of objects, which a dispatcher can perceive at the same time (computations, recommendations as for augmentation possibility of normative indexes for condition of correcting groupment); 2) Workplace geometry influence estimations on human (state potential, necessary for adaptation, determines an influence degree; disagreements workplace and PM topologies – its address; groups disparity and symmetry – orders areas of exchanges. Absolute sizes and measuring units determine in calibration motion. Give the recommendations as for functional workplaces destination of different form, dimensions computation, compensation possibilities); 3) Concordance of labour intensity with natural and biological rhythms (determine time structure, critical days and intervals, connections to dates and day time).

*Recognition model and making decision (MPP).* Introduce specific definitions of *image compactness, images sameness, encoding correctness and recognition reliability*. Consider the tasks: 1. Exposure of mechanisms of born recognition superiorities, proceeding from image forming

sequence and signs priorities in according MPP; 2. Design of prognostic interactive systems (offer the visualization methods and processes development tendencies interpretation).

*An operator management actions model (OM) is built in appearance object-functional weighed graph. Recommendations for management organs choice. Introduce the optimality indexes of their composing (deviation measures, effectiveness, correspondence). Offers information reverberation system decision (codes choice, management motions, suitable technical methods).*

*Information reverberation system design technology (data base (DB) architecture, variants search heuristics, automation of some projection stages) demonstrates by COMP-97 pilot-software on Fig. 2.*

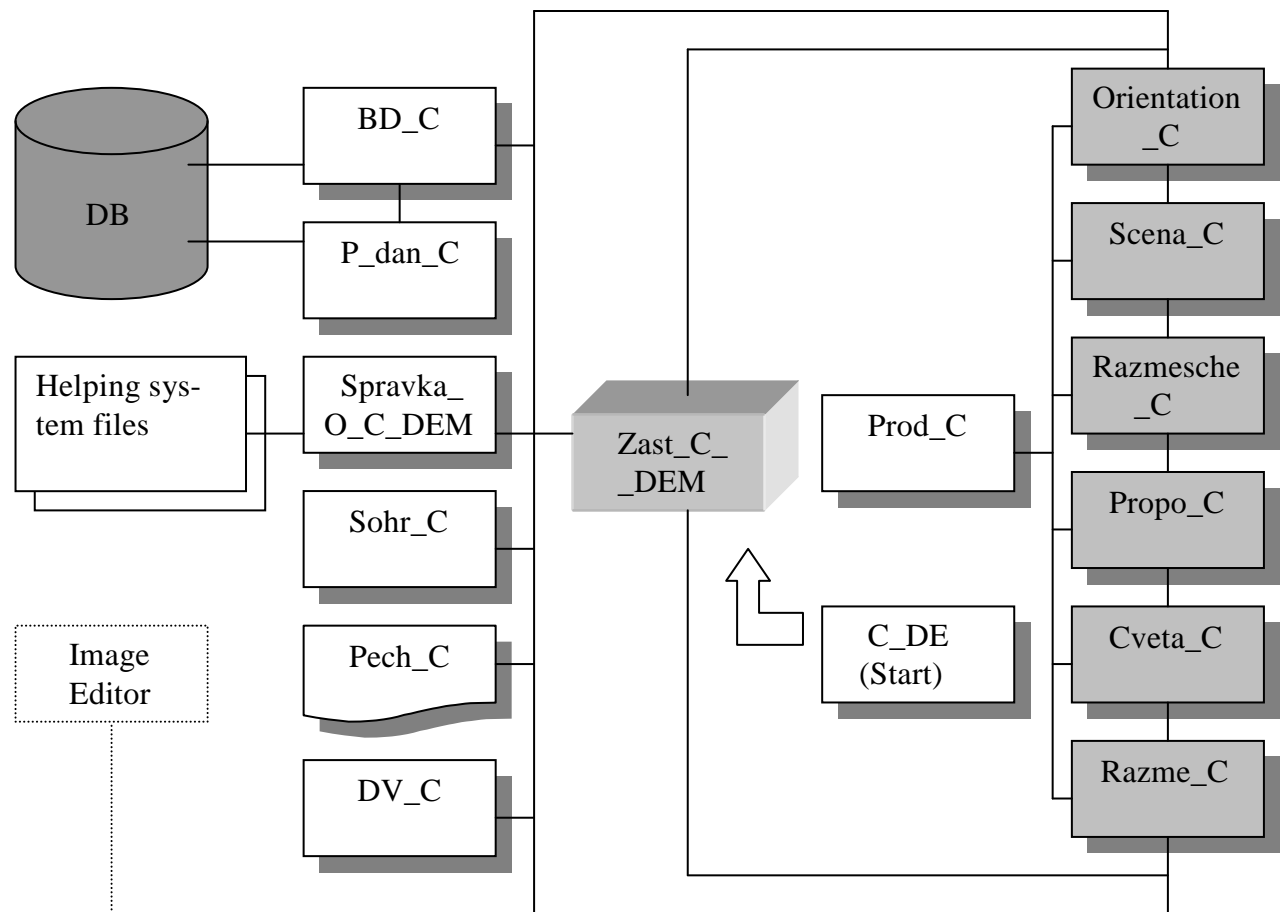

Fig. 2. COMP-97 packet structure

A software was created in Delphi 3 environment; it functions under Windows-95/98 and needs 2,2 Mb on hard disc. Functions of separate modules are such:

C\_DE takes care given about resources and modules intercourses and falls to execution of programs;

Zast\_C\_DEM provides a choice between demonstration modes, appeal to helping system, going out to Windows from by liberation of resources;

Orientation\_C offers to fix on pannel orientation, to be accorded reference whether to apply to DB;

Scena\_C will bring choice of scenery;

Razmesche\_C lends a possibility to correct composing scheme, to store it, to weigh with analogues, to printed it, to calculate first object function;

Propo\_C helps to define the placing zones proportions and devices (appeal to references and DB, loading of hints, correcting of proportions, object function calculation), executes operations of preservation, printing returning;

Cveta\_C takes a possibility to choose and to change colour decision, to acquaint with decisions-analogues, to obtain reference;

Razme\_C accomplish composing of panel, calculates the dimensions, executes operations of preservation, printing returning;

Prod\_C provides a transition to any composing stage;

BD\_C imitates a DB interface;

P\_dan\_C directly works with textual and graphic material;

Sohr\_C organizes saving of results;

Pech\_C provides printing;

DV\_C in case, when some from possibilities definite in menu are not realized, communicates to this to user and correctly accomplish command treatment;

Spravka\_O\_C\_DEM provides a search to file of hint system.

*Graphic model of subjective operator space.* Introduce a special diagram, quasimetrical attitude, as intercourses of psychological descriptions. For example, distance  $d$  introduces as a resemblance measure:

$$d = l + |sign_k \cdot \pi_k - sign_i \cdot \pi_i|, \quad (6)$$

where  $l$  – amount of transitions between elements layers  $k$  and  $i$ ;

$\pi_k, \pi_i$  – their potentials;

sign={+, modality (;- , modality \downarrow; 0, modality \downarrow}

Testing results reverberation procedure by the medium of such model and notes its superiorities are described. Professional qualities, and also the methods reach of their research are determined and ranked. Stowage procedures and graphic presentation of psychological portrait are given.

*Suggestions on the labour productivity control* measuring organization is ought to satisfy to axioms 4.1, 4.2; amount and weight of measured indexes to answer HEM, is possible considerable amount abbreviation of measuring, for correlation taking account condition of different indexes in according with HEM. The examples: computation of ergonomic parameters and modeling of stress development and pathological changes; planning of ergonomic arrangements.

## Conclusion

A vehicle of geometrical modeling, adequate to properties of complicated open systems was designed. The practical results, foremost in ergonomics, certify his value and for modeling of ecological systems and processes, because they produce to models analogical demands.

## References

1. Kovaluov Y. N. Geometry modeling of human-machine systems: designing of the vehicle.-Kyiv: KMUGA, 1996.-134 p.
2. Kovaluov Y. N. Human factor optimization of control on the basis of S-space models.- Kyiv: KMUGA, 1997.-152 p.