

DESIGN OF A WEATHER-COMPENSATED TEMPERATURE REGULATOR BASED ON MICROCONTROLLERS

National Aviation University, Kyiv, Ukraine

E-mails: ¹svm@nau.edu.ua, ²evg.daskal@gmail.com

Abstract—The design of a weather-compensated temperature regulator based on microcontrollers is considered. The software of design of a weather-compensated temperature regulator based on microcontrollers is developed.

Index terms—Design; weather-compensated temperature regulator based software.

I. INTRODUCTION

One of the main areas of the temperature regulators (TR) application is a heating of different types of apartments. Nowadays the costs of heating are quite considerable therefore it makes sense to use special TR for control of the consumed heat amount. The use of TR makes sense both in case of individual, and of the centralized systems of heating. The actual problem for them is receiving a surplus heat by the consumer during transient periods (spring or autumn) when the temperature of an atmospheric air constantly changes from 0 to +15°C depending on weather conditions [1]. During such periods it is created the situation when the consumer receives more heat than it is necessary, but whatever pays for the consumed heat or for the heat carrier in case of individual systems. For maintenance of comfortable indoor temperature the consumer is forced to take away the excess heat by airing through open windows.

In the same purposes of economy it should be taken into account that indoor temperature not necessarily always should be identical. For example, for industrial premises at night or in certain days of a calendar people aren't there. And that is also actual for the living apartments, the heating system optimal temperature should depend on other sources of heat there (for example, number of people or the working computers).

II. PROBLEM STATEMENT

For a solution of the above described problems the best solution will be the using of automatic TR with possibility of thin tuning and programming which will provide:

– maintenance of optimal temperature indoors by temperature regulation of the heat carrier in a heating contour. The optimum temperature should be defined on basis of temperature in and outside of the apartment, i.e. to be dependent on weather. Therefore, it should be installed the temperature

sensors of out- and indoor apartments air connected to the regulator;

– automatic correction of indoor temperature depending on time and date. For this TR should be able to count time and to conduct a calendar with possibility of manual installation of the nonworking days and daily diagrams;

– regulation of temperature of the heat carrier, in this case – liquid should be carried out on PID law by applying the signals “More” and “Less” on the actuating mechanism (AM). The actuating mechanism is the adjustable flap in the delivery pipeline;

– control the heating system state by comparison of temperature sensors indications with the set limit values. At an output of any value from the set limits the alarm system should work;

– indication of a heating system current state and regulator operation mode;

– testing of TR operability in a manual mode;

– keeping a log of heating system state. It gives the possibility to define the reason and the time of emergency and also to analyze the work of all system;

– remote access to the regulator including through the USB interface for notebook connection.

The last two points are especially actual for use in industrial premises as allow centrally controlling all systems on manufacture from the operator panel. The widely applied interfaces of remote access on manufactures in our time nowadays are interfaces RS-485 and RS-232.

III. WEATHER-COMPENSATED REGULATION

The implementation of a weather-compensated regulation requires the control device – controller which calculates, what temperature of the heat carrier corresponds to the temperature of outdoor air and taking into account indoor temperature maintains optimal temperature in a heating contour, giving out the corresponding signals on AM. It also

designate weather compensation or a weather-compensated regulation [2].

Regulation is carried out by the given dependence of the heat carrier temperature from the out of door air temperature called by a temperature curve (also called a heating curve) (Fig. 1). The steepness of a curve depends on a configuration of the apartment and heating system. The more precisely the temperature curve will be set, the overall system effectiveness and economy of energy will be higher.

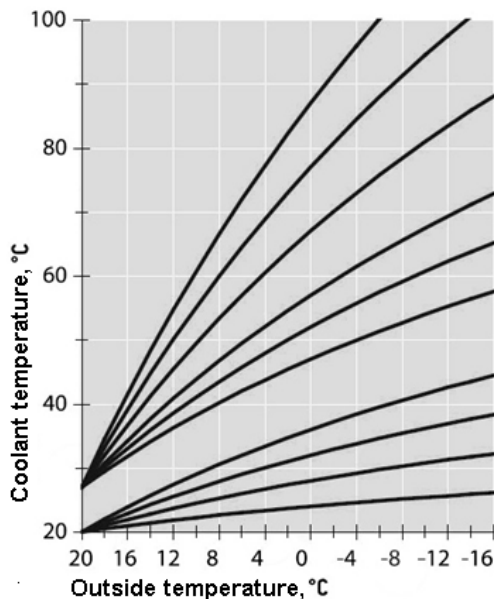

Fig. 1. Family of heating curves

At regulation it is also important to use indications of the temperature sensor indoors. If, for example, indoor temperature has increased that the controller will find this increase and that to compensate it, will lower a heating curve down and vice versa.

IV. STRUCTURAL SCHEME

In the market there is a large number of various weather-compensated TR intended both for control of heating elements of boilers, and for installation in systems of the centralized heating. In all these regulators as the control device microcontrollers are used – they are rather cheap and functional.

However the market lacks full-function universal devices which could be used in different systems of heating as inhabited and industrial premises. Such devices should implement at least all given in problem statement tasks and thus possess good user characteristics: flexibility of tuning, ease of control, speed and stability of functioning, etc. It is clear that for realization so many tasks it's necessary to have rather powerful and complex microcontroller which considerably will raise the cost of all device.

In that case it is possible to use two less powerful, but cheap microcontrollers, having separated between them executed tasks.

Proceeding from the requirements and notes described above was developed the weather-compensated temperature regulator (WCTR) which structural diagram is presented on Fig. 2.

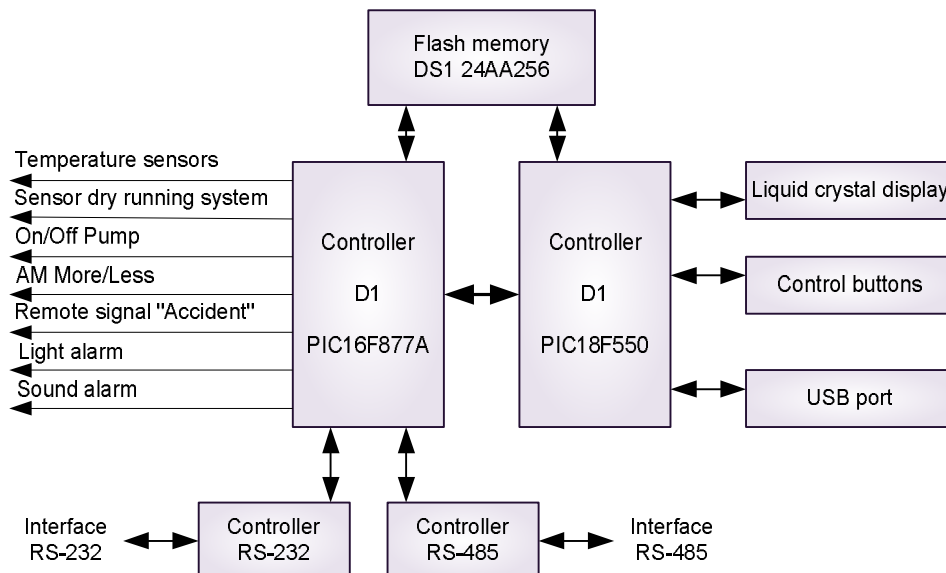

Fig. 2. Structural scheme of WCTR

All tasks in WCTR are distributed between two D1 and D2 microcontrollers. The main controller which is responsible for process of temperature regulation is the D1 controller. It accepts information from four

sensors: water temperature in the delivery pipeline, in the return pipeline, in the apartment and outside of the apartment, and also from a sensor dry running system of heating system. The D1 controller in turn

can give out control signals on AM (“More”, “Less”) and switching on / off signals of the pump. Also this controller provides the opportunity of switching on three types of the alarm signaling.

1. Remote signaling implies the delivery of a signal for the closure of remote-being relay if it is connected to the device in the corresponding connector.

2. Light signaling is a bulb on the device which lights up in case of emergency.

3. Sound signaling in case of accident turns on the high-frequency loudspeaker which is built in WCTR.

Also the D1 controller provides interaction with controllers of remote access on industrial RS-485 and RS-232 interfaces.

The D2 controller unloads the main controller and is intended for ensuring interaction of the regulator with the user, and also execution of minor operations (for example, the report of time or periodic logging). It services:

- the liquid crystal indicator (LCD) on which the current information on operation of the regulator is displayed: indications of temperatures of all sensors, the target temperature, the reason of emergency, date and time, the menu of tunings or other information depending on an operation mode;

- control buttons which provide the navigation according to the menu and a choice of an operation mode and other functions of entering data;

- port of the USB interface for connection to the regulator of the notebook and work with it (in the presence of the corresponding software on the notebook). The support of USB is built already in this controller therefore it does not need the external USB controller.

Both controllers have access to external non-volatile a flash memory of DS1 in which the log of system state of heating and tuning is stored. Also both controllers exchange necessary information on the I2C protocol.

In general such division of tasks ensures stable functioning of the regulator, change of tunings of the regulator without stopping of regulation process, timely reaction in case of emergencies.

V. SOFTWARE DESIGN

This WCTR except the main algorithm of work – regulation of temperature should implement also many other auxiliary algorithms which all together provide all functionality of the device. The block-diagram of WCTR software is represented in Fig. 3.

The regulator has 3 operation modes: “Work”, “Accident”, “Tuning”.

The “Work” mode is the basic and provides regulation of temperature. The user can select one of

three submodes: weather-compensated regulation, independent regulation or manual control.

At a weather-compensated regulation on the basis of the outdoor air temperature sensor indications using the temperature diagram (for example, such as on Fig. 1) the target temperature of the heat carrier is defined. Further the recalculation of this temperature taking into account time of day and a calendar is made. It becomes with help of daily work schedules for working and non-working days. In these schedules days share for 8 certain periods to each of which there corresponds its adjusting coefficient in the range from – 50 to + 50 %. Daily work schedules, and also working and non-working days are established in tunings. The counted value of target temperature is compared with water temperature in the delivery pipeline and if the difference between them is more than the set non-sensitivity zone value, the regulator passes to elimination of this error by supplying of the corresponding signals “More” or “Less” to AM. Elimination of a error can happen with help of discrete-pulse regulation or by PID law. All coefficients, duration of impulses and pauses between impulses are set in tunings.

Independent regulation is similar to a weather-compensated one except that target temperature is determined not by the schedule, but taken fixed and should be set in the tuning process.

Manual control allows to control manually the supplying of signals on AM by means of control buttons.

The regulator passes into the “Accident” mode if the indication of any sensor went beyond the set limits in tunings. It can be too high or on the contrary too low temperature value, sensor short circuit or open circuit, and also a signal of the dry course of the pump. In this mode system state record in log is made, all three signalings are switched on, the regulation of temperature is stopped and in case of the dry course of the pump it is given a signal stop of the pump. The regulator continues to be in this mode and to update indications from sensors until all emergency parameters do not return to the normal state.

The “Tuning” mode as appears from the name allows is thin to tune all parameters of regulator operation under needs of the user. As this mode is realized on the D2 controller (Fig. 2), it is possible to change tunings, without stopping thus the regulator operation.

In any mode except the “Tuning” mode on the LCD the current values of measurable temperatures (if there is an emergency value, it is highlighted), the calculated target temperature (or set), the current

adjusting coefficient, and also a date and time are displayed.

The regulator makes periodic record of the current state of heating system in log which is stored

in external flash memory. Also at the time of emergency situation detection immediate record is made. This log should be available through remote access to downloading.

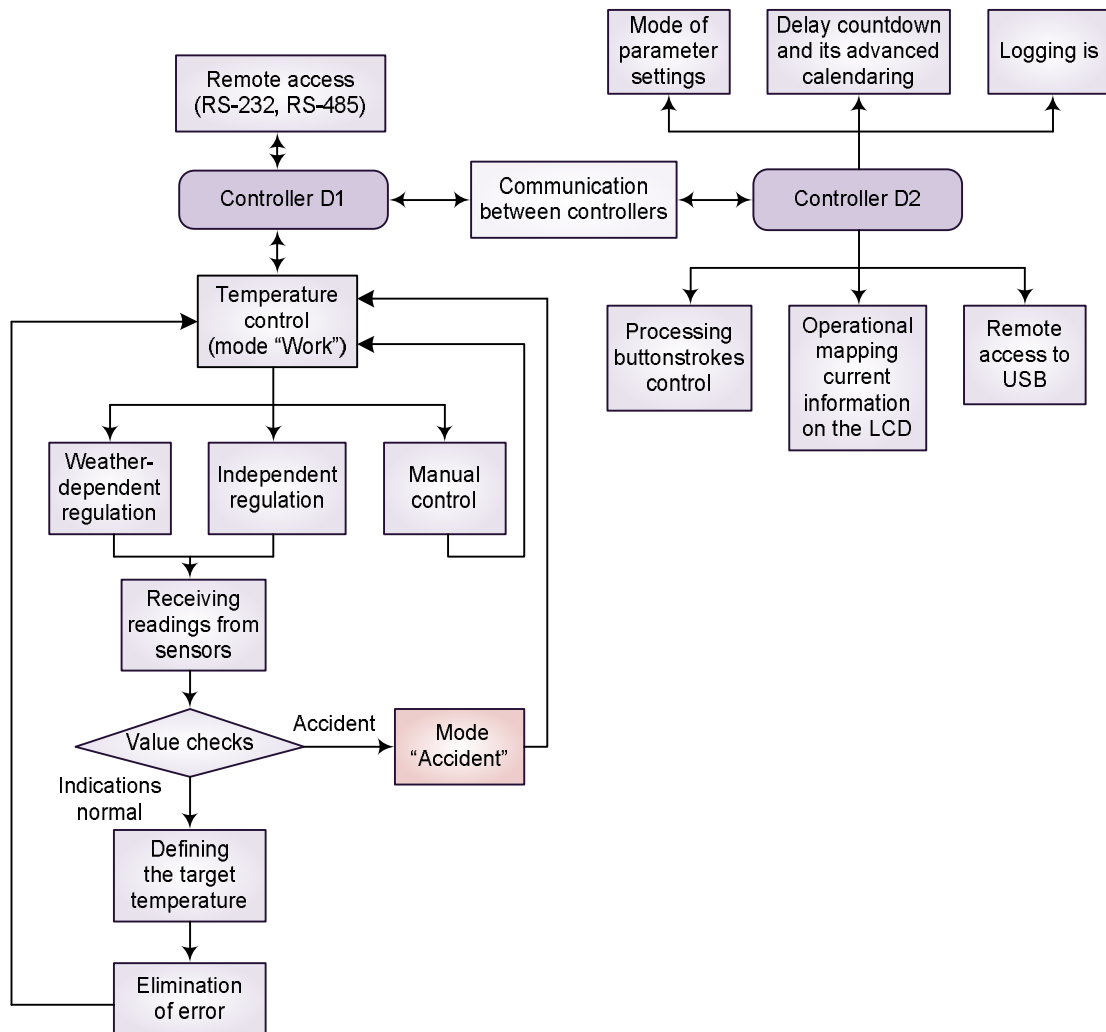

Fig. 3. Scheme of algorithmic providing WCTR

VI. INTERACTION OF D1 AND D2 MICROCONTROLLERS

After power supply giving the D1 controller passes into the main mode – “Work”, and the D2 controller in a standby mode of a session of an exchange with D1. The session of an exchange can be caused both from D1, and from D2, for example, when there was a pressed button or has load the internal timer (for example: when it is necessary to update information on the LCD).

At emergency the D1 controller passes into the “Accident” mode. The D2 controller is notified at once on transition from one mode to another. Depending on an operation mode the D2 controller transfers to D1 the relevant information on clicking of buttons. To the contrary, the current indications of sensors and other necessary parameters are regularly

reported to the D2 controller.

On the D2 controller the “Tuning” mode transition in which should be carried out irrespective of an operation mode of other controller is completely implemented. Thus all tunings are stored in external DS1 flash memory. On end of this mode to the D1 controller it is reported that tunings have been changed, and it can update them in the memory having addressed to DS1.

The current time, date and day of the week are stored in the D2 controller RAM. Their values with a certain regularity are transferred to the D1 controller for use them in algorithms of correction of temperature according to daily diagrams.

Controllers and flash memory are connected by the common bus and the exchange between them occurs in pairs under the I2C protocol.

CONCLUSION

The developed device – a weather-compensated temperature regulator differs in generic collection of functions which are necessary in this or that situation and possibility of thin tuning under needs of the consumer. The most distinctive opportunities, such as functions of remote access, tuning of operation of the regulator on daily diagrams and a calendar, storage of log and some types of the alarm signaling make suitable for use both in living, and in industrial apartments with the centralized or individual heating system. Use of two microcontrollers for execution of a certain part of tasks by everyone allows to reduce the price a little of the cost of the device and to increase stability of work and productivity, and also to increase number of useful functions. Besides, division of tasks between microcontrollers allows to separate also

tasks of composing of the computer program for them that can reduce development time.

Weather-compensated temperature regulator can be widely applicable on industry as it supports the RS-485 and RS-232 protocols that allows to unite all systems of plant heating and is centralized to control them.

REFERENCES

- [1] Baskakov, A.P.; Martyushev, A. P.; Zakharchenko, G. Ya.; Vedernikov, A. N. Regulation of temperature in living and public places – a perspective and effective method of energy saving. (in Russian). [E-resource] – Access mode: http://www.journal.esco.co.ua/2011_3/art167.htm
- [2] Bumagin, A. “Principles of creation of effective system of autonomous heating”. Akwa Term. 2010. no. 6(58). pp. 16–19. (in Russian).

Received 02 February 2015.

Sineglazov Viktor. Doctor of Engineering. Professor.

Aviation Computer-Integrated Complexes Department, National Aviation University, Kyiv, Ukraine.

Education: Kyiv Polytechnic Institute, Kyiv, Ukraine. (1973).

Research area: Air Navigation, Air Traffic Control, Identification of Complex Systems, Wind/solar power plant.

Publications: more than 450 papers.

E-mail: svm@nau.edu.ua

Daskal Evgen. Postgraduate.

Aviation Computer-Integrated Complexes Department, National Aviation University, Kyiv, Ukraine. (2014)

Education: National Aviation University, Kyiv, Ukraine.

Research interests: programming, systems and process control, computer-aided design.

E-mail: evg.daskal@gmail.com

В. М. Синеглазов, Е. В. Даскал. Проектування погодозалежного регулятора температури на базі мікроконтролерів

Розглянуто проектування погодозалежного регулятора температури на основі мікроконтролерів. Розроблено алгоритмічне та програмне забезпечення погодозалежного регулятора температури.

Ключові слова: проектування; алгоритмічне та програмне забезпечення; погодозалежний регулятор температури.

Синеглазов Віктор Михайлович. Доктор технічних наук. Професор.

Кафедра авіаційних комп'ютерно-інтегрованих комплексів, Національний авіаційний університет, Київ, Україна.

Освіта: Київський політехнічний інститут, Київ, Україна (1973).

Напрямок наукової діяльності: аеронавігація, управління повітряним рухом, ідентифікація складних систем, вітроенергетичні установки.

Кількість публікацій: більше 450 наукових робіт.

E-mail: svm@nau.edu.ua

Даскал Євген Вікторович. Аспірант.

Кафедра авіаційних комп'ютерно-інтегрованих комплексів, Національний авіаційний університет, Київ, Україна.

Освіта: Національний авіаційний університет, Київ, Україна. (2014)

Напрямок наукової діяльності: системи та процеси керування, системи автоматизованого проектування.

E-mail: evg.daskal@gmail.com

В. М. Синеглазов, Е. В. Даскал. Проектирование регулятора температуры на основе микроконтроллеров

Рассмотрено проектирование погодозависимого регулятора температуры на основе микроконтроллеров.

Разработано алгоритмическое и программное обеспечение погодозависимого регулятора температуры.

Ключевые слова: проектирование; алгоритмическое и программное обеспечение; погодозависимый регулятор температуры.

Синеглазов Виктор Михайлович. Доктор технических наук. Профессор.

Кафедра авиационных компьютерно-интегрированных комплексов, Национальный авиационный университет, Киев, Украина.

Образование: Киевский политехнический институт, Киев, Украина (1973).

Направление научной деятельности: аэронавигация, управления воздушным движением, идентификация сложных систем, ветроэнергетические установки.

Количество публикаций: более 450 научных работ.

E-mail: svm@nau.edu.ua

Даскал Евгений Викторович. Аспирант.

Кафедра авиационных компьютерно-интегрированных комплексов, Национальный авиационный университет, Киев, Украина.

Образование: Национальный авиационный университет, Киев, Украина (2014)

Направление научной деятельности: программирование, системы и процессы управления, системы автоматизированного проектирования.

E-mail: evg.daskal@gmail.com