

МІНІСТЕРСТВО ОСВІТИ ТА НАУКИ УКРАЇНИ
НАЦІОНАЛЬНИЙ АВІАЦІЙНИЙ УНІВЕРСИТЕТ

Кафедра конструкції літальних апаратів

ДОПУСТИТИ ДО ЗАХИСТУ
Завідувач кафедри
д-р техн. наук, проф.
_____ С. Р. Ігнатович
« _____ » _____ 2020 р.

ДИПЛОМНА РОБОТА
(ПОЯСНЮВАЛЬНА ЗАПИСКА)
ЗДОБУВАЧА ОСВІТНЬОГО СТУПЕНЯ
"БАКАЛАВР"

Тема: «Аванпроект дальномагістрального літака високої пасажиромісткості»

Виконала: _____ **Р.В. Артюх**

Керівник: канд.техн.наук, доцент _____ **М.В. Карускевич**

Нормоконтролер: канд.техн.наук, доцент _____ **С.В. Хижняк**

Київ 2020

MINISTRY OF EDUCATION AND SCIENCE OF UKRAINE

NATIONAL AVIATION UNIVERSITY

Department of Aircraft Design

AGREED

Head of the Department

Professor, Dr. of Sc.

_____ S.R. Ignatovych

« ____ » _____ 2020 y.

DIPLOMA WORK

(EXPLANATORY NOTE)

OF ACADEMIC DEGREE

«BACHELOR»

Theme: «Preliminary design of a high seating capacity long range aircraft»

Performed by:

R.V. Artiukh

Supervisor: PhD, associate professor

M.V. Karuskevich

Standard controller: PhD, associate professor

S.V. Khizhnyak

Kyiv 2020

NATIONAL AVIATION UNIVERSITY

Aerospace Faculty

Department of Aircraft Design

Academic Degree «Bachelor»

Speciality: 134 "Aviation and Rocket-Space Engineering"

APPROVED

Head of the Department

Professor, Dr. of Sc.

_____S.R. Ignatovych

«___»_____2020 year

TASK

for bachelor diploma work

ARTIUKH ROSTYSLAV

1. Theme: «**Preliminary design of cargo short range aircraft with cargo capacity 7,5 tons**»

Confirmed by Rector's order from 05.06.2020 year № 801/CT

2. Period of work execution: from 25.05.2020 year to 21.06.2020 year.

3. Work initial data: cruise speed $V_{cr}=570$ km/h, flight range $L=1000$ km, operating altitude $H_{op}=9$ km.

4. Explanation note argument (list of topics to be developed): choice and substantiations of the airplane scheme, choice of initial data; engine selection, aircraft layout, center of gravity position calculation, designing of ball mat.

5. List of the graphical materials: general view of the airplane (A1×1); layout of the airplane (A1×1); ball transfer unit drawing (A1×1)

Graphical materials are performed in AutoCad.

6. Calendar Plan

Task	Execution period	Signature
Task receiving, processing of statistical data	25.05.2020–28.05.2020	
Aircraft geometry calculation	29.05.2020–30.05.2020	
Aircraft layout	29.05.2020–31.05.2020	
Aircraft centering	31.05.2020–04.06.2020	
Graphical design of the parts	02.06.2020–10.06.2020	
Preliminary defence	10.06.2020–10.06.2020	
Completion of the explanation note	11.06.2020–15.06.2020	

7. Task issuance date: 25.05.2020 year

Supervisor of diploma work _____ M.V. Karuskevich

Task for execution is given for _____ R.V. Artiukh

ABSTRACT

Explanatory note to the diploma work «Preliminary design of cargo short range aircraft with cargo capacity 7,5 tons» contains:

pages, figures, tables, references and 4 drawings

Object of the design is development of cargo short-range aircraft with cargo capacity 7,5 tons.

Aim of the diploma work is the preliminary design of the aircraft and its design characteristic estimation.

The method of design is analysis of the prototypes and selections of the most advanced technical decisions, the geometrical characteristics estimation, centre of gravity calculations of the designing aircraft.

The diploma work contains drawings of the short-range aircraft with a carrying capacity of 7,5 tons, calculations and drawings of the aircraft layout and ball mat.

The materials of the diploma could be recommended for the students of aviation specialties, for the aircraft operational companies, etc.

AIRCRAFT PRELIMINARY DESIGN, LAYOUT, CENTER OF GRAVITY POSITION, BALL MAT, BALL TRANSFER UNIT

CONTENT

Introduction	1
1. Aircraft preliminary design	3
1.1. Planes-analogous	3
1.2. Designed aircraft description	5
1.2.1. Wing	5
1.2.2. Engines.....	6
1.2.3. Empennage.....	8
1.2.4. Undercarriage.....	8
1.3. Aircraft geometry	9
1.3.1. Wing geometry calculation	9
1.3.2. Fuselage layout	14
1.3.3. Layout and calculation of basic parameters of empennage.....	16
1.3.4. Landing gear design.....	17
1.4. Engine selection	18
1.5 Aircraft center of gravity calculation	19
2. Ball mat design for proposed aircraft	24
2.1. Ball mat principle of work	24
2.2. Ball mat design.....	26
2.3. Calculation of ball mat panel	27
2.4. Determination of ball mechanism type	27
2.5. Determination of ball mechanism type	32
General Conclusion	33
References	34

<i>Department of aircraft design</i>				<i>NAU 20 01A 00 00 00 20 EN</i>			
<i>Performed by</i>	<i>Artiukh R.V.</i>			<i>Content</i>	<i>Letter</i>	<i>Sheet</i>	<i>Sheets</i>
<i>Supervisor</i>	<i>Karuskevich M.V.</i>						
<i>Adviser</i>							
<i>Stand.contr.</i>	<i>Khizhnyak S.</i>				<i>AF 402 134</i>		
<i>Head of dep.</i>	<i>Ignatovych S.</i>						

Introduction

According to the task on diploma work the preliminary design of Short Take-off and landing cargo plane (main part) has been performed with design of ball mat for the cargo compartment (special part).

The plane has following parameters:

- commercial load: 7500 kg;
- cruising speed: 570 km/h;
- range with maximum payload: 1000 km;
- number of Engines: 2;
- engine bypass ratio: 5;
- wing aspect ratio: 7.5;
- wing taper ratio: 2.67;
- wing sweep-back angle: 22 degrees;
- fuselage diameter: 3.10 m;
- fuselage aspect ratio: 9.05;
- horizontal stabilizer sweep-back angle: 30 degrees;
- vertical stabilizer sweep-back angle: 35 degrees;

The ball mat provides cargo ease of transportation, handling, loading and unloading. Also it provides transfer loaded pallets without additional unpacking or re-packing.

The design is proposed as a result of “analysis and synthesis” process, based on the analysis of similar planes recently designed by leading world design bureaus. The planes AN-72, AN-74, Boeing YC-14, have been selected as prototypes for new machine.

<i>Department of Aircraft Design</i>				<i>NAU 20 01A 00 00 00 20 EN</i>			
<i>Performed by</i>	<i>Artiukh R.V.</i>			<i>Introduction</i>	<i>Letter</i>	<i>Sheet</i>	<i>Sheets</i>
<i>Supervisor</i>	<i>Karuskevich M.V.</i>						
<i>Adviser</i>							
<i>Stand.contr.</i>	<i>Khizhnyak S.V.</i>				<i>AF 402 134</i>		
<i>Head of Dep.</i>	<i>Ignatovich S.R.</i>						

The preliminary design of new plane is carried out in compliance with Federal Aviation Regulations, Certification Specifications, as well as national regulating documents.

The diploma work comprises: a) analysis of current trends in aircraft design and manufacturing; b) selection of the aircraft parameters; c) computing additional aircraft parameters; d) drawing of aircraft scale model by calculated parameters; e) comparison and conclusion.

Drawings are conducted with application of CAD and drafting software.

					<i>NAU 20 01A 00 00 00 20 EN</i>	<i>Sheet</i>
<i>Ch.</i>	<i>Sheet</i>	<i>Document No</i>	<i>Signed</i>	<i>Date</i>		<i>2</i>

1. AIRCRAFT PRELIMINARY DESIGN

1.1. Planes-prototypes

The preliminary design stage begins with the accumulation of data related to the previous successful machines plays an important role designed in Ukraine and abroad.

This stage can be called as a “Analysis and Synthesis”. Selection of the planes-analogous has been performed by the criteria of similar function, aerodynamic scheme, takeoff weight, cruising speed, cruising altitude, cargo capacity, fuel consumption, etc.

In the field of cargo planes design the Antonov Design Bureau takes special place. Thus, for new plane preliminary design the cargo aircraft of Antonov were considered first of all.

The experience of leading foreign aircraft manufactures has been taken into account as well.

For the synthesis and analysis, presented in this diploma work, the planes AN-72, AN-74, and Boeing YC-14 have been selected.

Data required for the selection of basic parameters is presented in table 1.1.

<i>Department of aircraft design</i>				<i>NAU 20 01A 00 00 00 20 EN</i>			
<i>Performed by</i>	<i>Artiukh R.V.</i>			<i>Main part</i>	<i>Letter</i>	<i>Sheet</i>	<i>Sheets</i>
<i>Supervisor</i>	<i>Karuskevich M.V.</i>						
<i>Adviser</i>							
<i>Stand.contr.</i>	<i>Khizhnyak S.V.</i>				<i>AF 402 134</i>		
<i>Head of Dep.</i>	<i>Ignatovich S.R.</i>						

Table 1.1 – Operational-technical data of prototypes

PARAMETER	PLANES		
	An 72	An 74	Boeing YC-14
The purpose of airplane	Cargo	Cargo	Cargo
Crew/flight attend. Persons	3/2	3/2	2/1
Maximum take-off weight, m_{tow} , kg	32 000	30200	77270
Most pay-load, $m_{k.max}$, kg	18260	18000	15000
The height of the flight $v_{w. Ek}$, m	10 100	10 100	13716
Range $m_{k.max}$, km	4700	5700	5136
Take off distance $l_{3л.д.}$, m	800	1000	1200
Number and type of engines	2xД-36	2xД36	2xCF650D
The form of the cross-section fuselage	Circular	Circular	Circular
Extension of the fuselage	2,1	2,3	1,8
Sweepback on 1/4 chord, °	20	22	15
Commercial load, kg	7400	8000	11000
Cruising speed, km/h	560	580	600
Range with maximum payload, km	1100	1300	800
Bypass ratio	4.7	4.9	4.7
Aspect ratio	7.5	7.5	7.3
Taper ratio	2.67	2.65	2.4
Fuselage diameter, m	3.1	3.1	4
Horizontal stabilizer sweep-back angle, °	30	30	35
Vertical stabilizer sweep-back angle, °	35	35	33
Optimal lift force coefficient	0.3	0.35	0.36
Take-off speed, km/h	203	180	170
Lift-off distance, m	611	596	587
Safety altitude distance, m	600	587	576
Full take-off distance, m	1211	1183	1163
Maximum landing weight, kg	30000	28045	70000
Average fuel consumption, kg/h	1653	1566	2364
Specific fuel consumption (take-off)	41.26	39.26	62.33
Specific fuel consumption (cruising)	51.37	51.37	77.45
Take-off thrust of one engine, kn	63,76	63,76	230

As a result of the data presented analysis the primary characteristics for new aircraft have been selected and substantiated.

1.2. Designed aircraft description.

The idea of an airplane that does not require special airfields is as old as the history of aviation itself. Designers have repeatedly tried to implement it, with more or less success trying to create an airplane that combines high enough flight qualities with low landing speed.

High wing. Has a swept wing. The unusual arrangement of engines on top of the wing in a forward engine nacelle increases lift due to the Coanda effect. With slats and flaps deflected, the jet stream escaping from the engine nozzle “sticks” to the wing, flowing over the upper surface of the wing and flap without tearing off, accelerates the air flow above it. According to the laws of aerodynamics, an increase in the flow rate leads to a decrease in air pressure. And the greater the pressure difference under and above the wing, the greater the lifting force, and therefore the take-off and landing characteristics of the aircraft improve.

So advantages of using combination of high wing location with upper surface blowing (USB) results Coanda effect. Such scheme with landing gear that strength and energy absorption of the shock absorbers were calculated to overcome the “standard bump” up to 35 cm high can provide operation of aircraft with unprepared airfields with short take-off and landing distance.

Wing. The supercritical design promised to greatly lower transonic drag, as much as a swept wing in some situations. This allowed an aircraft with such a wing to have low drag in cruise while also having a wing planform more suitable to lower-speed flight—swept wings have several undesirable characteristics at low speed. Additionally, the design has a larger leading edge radius that makes it particularly suitable for low-speed high-lift applications like a transport. Boeing incorporated the concept into their design, the first non-experimental aircraft to do so. As well as Boeing, Antonov’s engineers also decided to combine supercritical airfoil with upper surface blow (USB) of engine.

The Boeing engineers were aware that NASA had carried out a series of "powered lift" studies some time earlier, including both externally blown flaps, as

					<i>NAU 20 01A 00 00 00 20 EN</i>	<i>Sheet</i>
<i>Ch.</i>	<i>Sheet</i>	<i>Document No</i>	<i>Signed</i>	<i>Date</i>		5

well an upper-surface blowing (USB), an unusual variation. In the USB system, the engine is arranged over the top surface of the wing, blowing over the flaps. When the flaps are lowered, the Coandă effect makes the jet exhaust "stick" to the flaps and bend down toward the ground. They searched for additional research on the concept, and found that half-span upper-surface blowing research had been conducted in the NASA Langley 12-foot (3.7 m) tunnel. An examination of the preliminary results suggested that the system was as effective as any of the other concepts previously studied. Boeing immediately started to build wind-tunnel models to verify the NASA data with layouts more closely matching their own designs. By the end of 1971, several models were being actively studied.

We can definitely say that idea of USB belongs to Boeing and NASA and Antonov's engineers only improved technology. That is why AN-72 and AN-74 are success airplanes rather than Boeing YC-14.

Engines. Engines are mounted on the upper surface of the wing, this scheme ensures the adhesion of the flow - Coanda effect. To prevent stalling, the jet stream must be powerful and interact with wing high lift devices.

The advantages of such a scheme are:

- streamlining without stalling at large angles of attack
- high engine position prevents runway debris from taking off and landing
- less load on the fuselage
- best directional stability

Engine CF6-50. The CF6-50 series are high-bypass turbofan engines rated between 51,000 and 54,000 lb (227.41 to 240.79 kN, or '25 tons') of thrust. The CF6-50 was developed into the LM5000 industrial turboshaft engines. It was launched in 1969 to power the long range McDonnell Douglas DC-10-30, and was derived from the earlier CF6-6. Not long after the -6 entered service, an increase in thrust and therefore core power was required. Unable to increase (HP) turbine rotor

					<i>NAU 20 01A 00 00 00 20 EN</i>	<i>Sheet</i>
<i>Ch.</i>	<i>Sheet</i>	<i>Document No</i>	<i>Signed</i>	<i>Date</i>		6

inlet temperature, General Electric chose the expensive path of reconfiguring the CF6 core to increase its basic size. They removed two stages from the rear of the HP compressor, leaving an empty air passage where the blades and vanes had once been. Two booster stages were added to the LP (low pressure) compressor, which increased the overall pressure ratio to 29.3. Although the 86.4 in (2.19 m) diameter fan was retained, the airflow was raised to 1,450 lb/s (660 kg/s), yielding a static thrust of 51,000 lb_f (227 kN). The increase in core size and overall pressure ratio raised the core flow, decreasing the bypass ratio to 4.26.

Engine Lotarev D-36. The engine was developed for the Yak-42, An-72 and An-74 aircraft and was very advanced when it was first introduced in the 1970s. The engine was designed by Vladimir Lotarev. The first test runs began in 1971, first flight tests followed in 1974, serial production began in 1977.

The engine has a single-stage fan with 29 titanium blades and a Kevlar outer shell, which is driven by a three-stage turbine. The six-stage low pressure compressor with titanium blades is driven by a single-stage non-cooled low pressure turbine. The seven-stage high-pressure compressor with steel blades is driven by a steel bladed high-pressure turbine.

Since the tradition in the Soviet era was to gradually and continuously improve engines in serviceability, engines went from Series 1 to 3A (depending on the application). The Series 1 (used on Yak-42D) did not feature any reverse thrust system however, series 1A to 3A were fitted with bucket-type thrust reversers (used on An-72/An-74). The most recent upgrade (after the Soviet breakup) is Series 4A which has been in manufacture since 2002. Improvements included updated curved titanium blades and a built-in reverse thrust device. More advanced blade design along with proprietary wear-resistant and heat-protective coatings have resulted in improved specific fuel consumption (kg/h/kgf) dropping from 0.65 to 0.63. Specified service life has also improved exponentially to 40,000 hours.

					<i>NAU 20 01A 00 00 00 20 EN</i>	<i>Sheet</i>
<i>Ch.</i>	<i>Sheet</i>	<i>Document No</i>	<i>Signed</i>	<i>Date</i>		7

Empennage. A powerful fin is installed on the aircraft to ensure directional stability. The rudder has an original two-hinged design, which increased its efficiency at low speeds, and is divided into two sections in height. The lower rear of the steering wheel is controlled directly by the pedals of the pilot, and the rest - by boosters of the control system. To reduce the effort in the control system over a wide range of flight modes and aircraft alignments, the rudders have weight and aerodynamic balancing, the lower section of the second link of the rudder is equipped with a trimmer, and the elevator with trimmers and servo compensators. Such a solution makes it possible for pilots to counterbalance the imbalance of the aircraft during the release of wing mechanization (the flow around the aircraft changes dramatically and at low speeds it literally “hangs” on the engines) and manually pilot the aircraft even if the boosters fail.

Undercarriage. Ultimately, the choice was made in favor of a conventional retractable chassis with a controllable front pillar and four powerful main pillars with independent linkage. The durability and energy absorption of the shock absorbers were calculated to overcome the “standard bump” with a height of up to 35 cm. To increase safety, the main racks do not have locks of a retracted position that could clog up with dirt on takeoff and not open. The removed racks lie on the wings of the chassis niches and when they open, they freely fall. If the hydraulic system fails, the landing gear is mechanically released, and if one of the main pillars fails, the plane could land on the three remaining

					<i>NAU 20 01A 00 00 00 20 EN</i>	<i>Sheet</i>
<i>Ch.</i>	<i>Sheet</i>	<i>Document No</i>	<i>Signed</i>	<i>Date</i>		8

1.3. Aircraft geometry.

The geometrical parameters are found on the base of the calculations results presented in table 1.1.

1.3.1. Wing geometry calculation

Geometrical characteristics of the wing are determined from the take of weight m_0 and specific wing load P_0 .

Wing loading value has been accepted on the base of similar planes analysis.

For the designed plane it was chosen to be equal to $148,54 \text{ kg/m}^2$

From this:

Full wing area with extensions is:

$$S_{\text{wing}} = \frac{m_0 \cdot g}{P_0} = \frac{91295 \cdot 9.8}{4153} = 215.43 \text{ (m}^2\text{)}$$

The following wing parameters were found:

Relative wing extensions area is 0.1;

-Wing area is: $S_w=107.5 \text{ [m}^2\text{]}$;

-Wing span is: $l_w=31890 \text{ [m]}$;

-Root chord is: $b_0=4.55 \text{ [m]}$;

-Tip chord is: $b_t=1.500 \text{ [m]}$;

On board chord for trapezoidal shaped wing is:

$$b_{ob}=4.241 \text{ [m]}$$

Among the main wing geometrical parameters, the following values have been selected.

Aspect ratio.

An important characteristic of the wing is an aspect ratio. The greater the aspect ratio of the wing, the more efficient is the wing aerodynamically.

Some examples of the aspect ratio values are presented in table 1.2.

For proposed plane the value of aspect ratio 7.5 has been selected.

					NAU 20 01A 00 00 00 20 EN	Sheet
Ch.	Sheet	Document No	Signed	Date		9

Table 1.2 Aircraft wing aspect ratio examples

№	Aircraft type	Aspect ratio
1	Hand glider	4-8
2	Glider (sailplane)	20-40
3	Homebuilt	4-7
4	General Aviation	5-9
5	Jet trainer	4-8
6	Low subsonic transport	6-9
7	High subsonic transport	8-12
8	Supersonic fighter	2-4
9	Tactical missile	0.3-1
10	Hypersonic aircraft	1-3

The taper ratio of the wing has been selected equal to 2.67 as a result of the following considerations:

a) The planform shape should not give rise to an additional lift distribution that is so far from elliptical that the required twist for low cruise drag results in large off design penalties; b) The chord distribution should be such that with the cruise lift distribution, the distribution of lift coefficient is compatible with the section performance. Avoid high C_l 's which may lead to buffet or drag rise or separation; c) The chord distribution should produce an additional load distribution which is compatible with the high lift system and desired stalling characteristics; d) Lower taper ratios lead to lower wing weight; e) Lower taper ratios result in increased fuel volume; f) The tip chord should not be too small as Reynolds number effects cause reduced C_l capability; g) Larger root chords more easily accommodate landing gear.

Here, again, a diverse set of considerations are important. The major design goal is to keep the taper ratio as small as possible (to keep the wing weight down) without excessive C_l variation or unacceptable stalling

characteristics.

Since the lift distribution is nearly elliptical, the chord distribution should be nearly elliptical for uniform Cl 's. Reduced lift or t/c outboard would permit lower taper ratios. The thickness to chord value has been selected equal to 0.140 because: We would like to make the t/c as large as possible to reduce wing weight (thereby permitting larger span, for example); b) Greater t/c tends to increase CL_{max} up to a point, depending on the high lift system, but gains above about 12% are small if there at all; c) Greater t/c increases fuel volume and wing stiffness; d) Increasing t/c increases drag slightly by increasing the velocities and the adversity of the pressure gradients; e) The main trouble with thick airfoils at high speeds is the transonic drag rise which limits the speed and CL at which the airplane may fly efficiently.

The sweep back angle has been selected equal to 22 degrees. The purpose of the swept back angle is an increase in the speed at which the wave crisis sets in, and as a result, less resistance at transonic speeds in comparison with a straight wing.

At a choice of structural scheme of the wing we determine quantity of spars and their position, and the places of wing portioning.

On the modern transport planes two spars or three spars designs are most conventional. The two spars design have been selected as appropriate.

I use the geometrical method of mean aerodynamic chord determination (figure 1.1). Mean aerodynamic chord is equal: $b_{MAC}=3.281$ [m].

									Sheet
									11
Ch.	Sheet	Document No	Signed	Date	NAU 20 01A 00 00 00 20 EN				

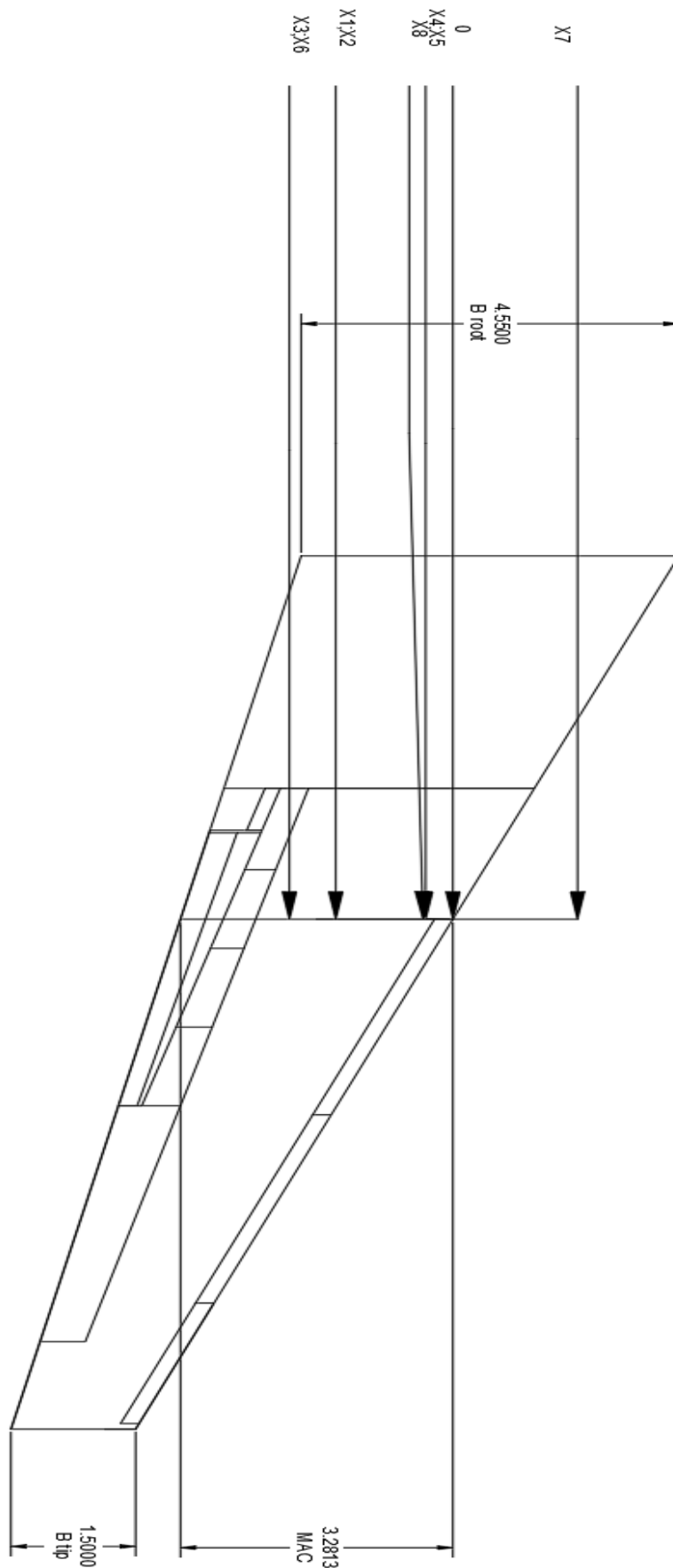

Fig.1.1. Detrmination of the mean aerodynamic chord

						Sheet
					NAU 20 01A 00 00 00 20 EN	12
Ch.	Sheet	Document No	Signed	Date		

After determination of the geometrical characteristics of the wing we come to the estimation of the ailerons geometrics and high-lift devices.

Ailerons geometrical parameters are determined in next consequence:

- Ailerons span: $l_{ail}=5.98$ [m];
- Aileron area: $S_{ail}=3.493$ [m²];

Increasing of l_{ail} and b_{ail} more than recommended values is not necessary and convenient. With the increase of l_{ail} more than given value the increase of the ailerons coefficient falls, and the high-lift devices span decreases. With b_{ail} increase, the width of the xenon decreases.

In the airplanes of the third generation there is a tendency to decrease relative wing span and ailerons area. In this case for the transversal control of the airplane we use spoilers together with the ailerons. Due to this the span and the area of high-lift devices may be increased, which improves take off and landing characteristics of the aircraft.

Aerodynamic compensation of the aileron.

Axial $S_{axinail} \leq (0.25 \dots 0.28) S_{ail} = 0.908$ [m²].

Inner axial compensation $S_{inaxinail} = (0.3 \dots 0.31) S_{ail} = 1.047$ [m²];

Area of ailerons trim tab.

For two engine airplane: $S_{tail}=0.174$

Range of aileron deflection

Upward $\delta'_{ail} \geq 20^\circ$;

Downward $\delta''_{ail} \geq 10^\circ$.

The aim of determination of wing high-lift devices geometrical parameters is the providing of take of and landing coefficients of wing lifting force, assumed in the previous calculations with the chosen rate of high-lift devices and the type of the airfoil profile.

Taking into the account the design of planes-prototypes and current trends in the design of high lift devices the Coanda effect double slotted flaps design has been proposed.

					<i>NAU 20 01A 00 00 00 20 EN</i>	Sheet
Ch.	Sheet	Document No	Signed	Date		13

Layout and geometrical parameters determination of wing high-lift devices. The main aim of this chapter is the providing of take off and landing coefficients of wing lifting force, assumed in the previous calculations with the chosen rate of high-lift devices and the type of the airfoil profile.

Before doing following calculations it is necessary to choose the type of airfoil due to the airfoil catalog, specify the value of lift coefficient $C_{y_{max}bw}$ and determine necessary increase for this coefficient $\bar{C}_{y_{max}}$ for the high-lift devices outlet by the formula: $\Delta\bar{C}_{y_{max}} = (C_{y_{max}l} / C_{y_{max}bw})$

Where $c_{y_{max}l}$ is necessary coefficient of the lifting force in the landing configuration of the wing by the aircraft landing insuring (it is determined during the choice is the aircraft parameters).

Effectiveness of high-lift devices ($C_{y_{max}l}^*$) rises proportionally to the wing span increase, serviced by high-lift devices, so we need to obtain the biggest span of high lift devices ($l_{hld} = l_w - D_f - 2l_{ail} - l_n$) due to use of flight spoiler and maximum diminishing of the are of engine and landing gear nacelles.

During the choice of structurally-power schemes, hinge-fitting schemes and kinematics of the high-lift devices we need to come from the statistics and experience of domestic and foreign aircraft construction. We need to mention that in the majority of existing constructions elements of high-lift devices are done by single spar structural scheme.

1.3.2. Fuselage layout

Based on the main tasks performed by the designed aircraft, the fuselage was designed to withstand the loads that affect it at subsonic speeds ($V < 800$ km/h).

During transonic and subsonic flights, the shape of the nose of the fuselage affects the wave resistance C_{xw} . So the fuselage aspect ratio:

$$\lambda_f = 2.1.$$

					<i>NAU 20 01A 00 00 00 20 EN</i>	Sheet
Ch.	Sheet	Document No	Signed	Date		14

According to cruising speed and taking into account wave resistance, fuselage nose part has to be:

$$L_{nfp}=6.51 \text{ [m]}.$$

Since the prototype is a short take-off and landing airplane, considering the loads acting on the fuselage, I took the circular cross-section shape of the fuselage.

The fuselage has a small diameter and since the plane is a cargo plane, I decided to lengthen the fuselage to accommodate a larger commercial load. The main task of the fuselage in this prototype is to remove and distribute the load from the wing to the fuselage, providing space for useful loads. Based on this parameters fuselage length:

$$l_f=25.735 \text{ [m]}.$$

From the design point of view it is convenient to have round cross section, because in this case it'll be the strongest and the lightest. But for passenger and cargo placing this shape is not always the most convenient one. In the most cases, one of the most suitable ways is to use the combination of two circles intersection, or oval shape of the fuselage. We need to remember that the oval shape is not suitable in the production, because the upper and lower panels will bend due to extra pressure and will demand extra bilge beams, and other construction amplifications.

Since the unloading and loading ramp is intended, among other things, for dropping cargo in flight, it rolled back along the guide under the fuselage. That is cause length of the fuselage rear part is equal:

$$l_{frp}=6.51 \text{ [m]}.$$

Step of normal bulkhead in the fuselage construction is in the range of 360...500mm, depends on the fuselage type.

					<i>NAU 20 01A 00 00 00 20 EN</i>	<i>Sheet</i>
<i>Ch.</i>	<i>Sheet</i>	<i>Document No</i>	<i>Signed</i>	<i>Date</i>		15

1.3.3. Layout and calculation of basic parameters of empennage

To maintain the controllability of the aircraft in flight and its stable behavior, the tail was selected with a T-shape and large fences were installed on the sides of the tail, reducing harmful interference.

Area of vertical tail unit is equal:

$$S_{vtu}=19.35 \text{ [m}^2\text{]}$$

The stabilizer mounted on top of the fin was outside the bevel of the stream behind the wing, and to ensure a larger range of working angles of attack, it was made interchangeable.

Area of horizontal tail unit is equal:

$$S_{htu}=26.875 \text{ [m}^2\text{]}$$

The stabilizer profile with a flat top surface and the installation of a deflector along the leading edge eliminates the risk of stall conditions.

The height of the vertical tail unit h_{bo} is determined accordingly to the location of the engines. Taking it into account we assume:

- Low wing, E_{onW} , $M < 1$, $h_{bo}=(0.14..0.2)l_w$;
- Engine in the root part of the wing, $h_{bo}=(0.13..0.165)l_w$;
- Engine in the tail part, $h_{bo}=(0.13..0.14)l_w$

Altitude elevator area: $S_{el}=7.43 \text{ [m}^2\text{]}$

Rudder area: $S_{rud}=4.52 \text{ [m}^2\text{]}$

To ensure directional stability, a powerful keel is installed on the plane. The rudder has an original double-hinged design, which increased its efficiency at low speeds, and is divided into two sections by height.

For high wing airplanes we need to set the upper limit.

Taper ratio of horizontal and vertical tail unit we need to choose:

- For planes $M < 1$ $\eta_{htu}=2...3$ $\eta_{vtu}=1...3.3$

The area of elevator trim tab:

$$S_{te}=0.5944 \text{ [m}^2\text{]}$$

					<i>NAU 20 01A 00 00 00 20 EN</i>	<i>Sheet</i>
<i>Ch.</i>	<i>Sheet</i>	<i>Document No</i>	<i>Signed</i>	<i>Date</i>		16

Area of rudder trim tab is equal:

$$S_{tr}=0.2712 \text{ [m}^2\text{]}$$

Root chord of horizontal stabilizer is:

$$b_{0htu}=5.46 \text{ [m]}$$

Tip chord of horizontal stabilizer is:

$$b_{t\text{htu}}=2.730 \text{ [m]}$$

Root chord of vertical stabilizer is:

$$b_{0vtu}=1.523 \text{ [m]}$$

Tip chord of vertical stabilizer is:

$$b_{t\text{vtu}}=0.662 \text{ [m]}$$

1.3.4. Landing gear design

In the primary stage of design, when the airplane center-of-gravity position is defined and there is no drawing of airplane general view, only the part of landing gear parameters may be determined.

Great attention in the design of this aircraft is given to the landing gear. The aircraft should have not only short take-off and landing, but also land on unprepared airfields.

Landing gear wheel base:

$$B = 8.190 \text{ [m]}$$

Front wheel axial offset will be equal:

$$d_{ng}=7,313 \text{ [m]}$$

Wheel track is: $T=4.140 \text{ m}$

Wheels for the landing gear is chosen by the size and run loading on it from the take off weight; for the front support we consider dynamic loading also.

Conventional retractable landing gear with a controllable front pillar and four powerful main pillars with independent linkage was chosen. To increase security, the main racks do not have locks of a retracted position that could clog up with dirt on take-off and not open. The removed racks lie on the flaps of the chassis niches and, when opened, freely lower. If the hydraulic system fails, the

					<i>NAU 20 01A 00 00 00 20 EN</i>	<i>Sheet</i>
<i>Ch.</i>	<i>Sheet</i>	<i>Document No</i>	<i>Signed</i>	<i>Date</i>		17

landing gear is mechanically released, and if one of the main struts fails, the plane lands on the three remaining.

The load on the wheel is determined:

$K_g = 1.5...2.0$ – dynamics coefficient.

Nose wheel load is equal:

$$P_{NLG}=30867.92 \text{ [N]}$$

Main wheel load is equal:

$$P_{MLG}=40218.275 \text{ [N]}$$

Table 1.3 – Aviation tires for designing aircraft

Main gear		Nose gear	
Tire size	Ply rating	Tire size	Ply rating
1050x400mm	18	720x310 mm	14

1.4 Engine selection

Turbofan engines with a high degree of bypass allow to implement the Coanda effect in practice. D-36, created in the Design Bureau of Progress by V.A. Lotarev, provided sufficient air flow, and, which is especially valuable, a relatively "cold" exhaust stream of gases directed to blowing the wing.

Table 1.4 – Examples of application Д-30КУ(КП)

Model	Thrust	Bypass ratio	Dry weight
Д-36	63.75 kN	5.6:1	1124 kg
Д-36 series 1A/2A	63.75 kN	5.6:1	1124 kg
Д-36 series 3A	63.75 kN	5.6:1	1124 kg

1.5 Aircraft center of gravity calculation

Mass of the equipped wing contains the mass of its structure, mass of the equipment placed in the wing and mass of the fuel. Regardless of the place of mounting (to the wing or to the fuselage), the main landing gear and the front gear are included in the mass register of the equipped wing. The mass register includes names of the objects, mass themselves and their center of gravity coordinates. The origin of the given coordinates of the mass centers is chosen by the projection of the nose point of the mean aerodynamic chord (MAC) for the surface XOY. The positive meanings of the coordinates of the mass centers are accepted for the end part of the aircraft.

The example list of the mass objects for the aircraft, where the engines are located on the upper surface of wing, included the names given in the table 1.4.

Determination of the mass power of the equipped fuselage

Origin of the coordinates is chosen in the projection of the nose of the fuselage on the horizontal axis. For the axis X the construction part of the fuselage is given. The example list of the objects for the aircraft, which engines are mounted to the upper surface of wing, is given in table 1.5.

The centre of gravity (C.G.) coordinates of the fully equipped fuselage are determined by formulas:

$$X_f = \frac{\sum m_i' X_i'}{\sum m_i'}$$

$$Y_f = \frac{\sum m_i' Y_i'}{\sum m_i'}$$

After we determined the C.G. of fully equipped wing and fuselage, we construct the moment equilibrium equation relatively fuselage nose:

$$m_f x_f + m_w (x_{MAC} + x_w') = m_0 (x_{MAC} + C)$$

$$X_{MAC} = \frac{m_f \cdot X_f + m_w \cdot x_w' - m_0 \cdot C_n}{m_0 - m_w} = 6,45 (m)$$

						Sheet
					NAU 20 01A 00 00 00 20 EN	19
Ch.	Sheet	Document No	Signed	Date		

Knowing the wings position relatively to fuselage on the layout drawing, we connect the wings power elements and the fuselage. After the wings and fuselage arrangement a C.G. calculation takes place. C.G. positioning is called the relative position of centre of masses relatively to MAC leading edge.

Table 1.5 Trim sheet of equipped fuselage masses.

N	Object name	Mass		C.g. Coordinates X_i, m	Moment of mass $M_i / x_i,$ $kg \cdot m$
		Units	Total mass $m(i)$		
1	Wing (structure)	0,118	4363,275	1,410	6155,839
2	Fuel system	0,001	55,831	1,410	78,768
3	Airplane control, 30%	0,002	101,377	1,968	199,571
4	Electrical equipment, 30%	0,002	80,808	0,328	26,513
5	Anti-ice system , 70%	0,012	462,810	0,328	151,848
6	Hydraulic systems , 70%	0,016	595,042	1,968	1171,400
7	Power plant	0,084	3087,240	-1,5	-4630,860
8	Equipped wing without landing gear and fuel	0,238	8746,385	0,360	3153,080
9	Nose landing gear	0,009	363,930	-6,59	-2398,303

Table 1.5 Continue

N	Object name	Mass		C.g. Coordinates X_i, m	Moment of mass $M_i / x_i,$ $kg \cdot m$
		Units	Total mass $m(i)$		
10	Main landing gear	0,039	1454,547	1,804	2624,003
11	Fuel	0,13	4844,451	1,410	6834,697
	Total	0,419	15409,316	-3,375	10213,47

Table 1.6 C.G. positioning sheet

Object name	mass in Kg, m_i	coordinate X_i, M	mass moment Kg.m
Equipped wing (without fuel and landing gear)	8746,385	6,812	59583,34
Nose landing gear (extended)	363,930	0,861	313,646
Main landing gear (extended)	1454,547	8,255	12008,51
Reservefuel	931,232		
Fuel	4844,451	7,862	38090,31
Equipped fuselage (without payload)	11609,934	9,848	114341,9
Cargo	8405,522	12,687	106645,1
Crew	375	3	1125
Nose landing gear (retracted)	363,930	0,861	313,646
Main landing gear (retracted)	1454,547	6,451	9384,504

Table 1.7 Airplanes C.G. position variants

№	Name	Maca, m_i kg	mass moment $m_i X_i$	center of mass X_{IM}	center X_C %
1	Take off mass (L.G. extended)	36730	294017,491	8,004	0,230
2	Take off mass (L.G. retracted)	36731,004	282008,954	7,677	0,323
3	Landing weight (LG extended)	31885,548	294017,491	9,222	0,167
4	Ferry version	28325,482	175363,924	6,191	0,02
5	Parking version	22549,798	186247,431	8,259	0,151

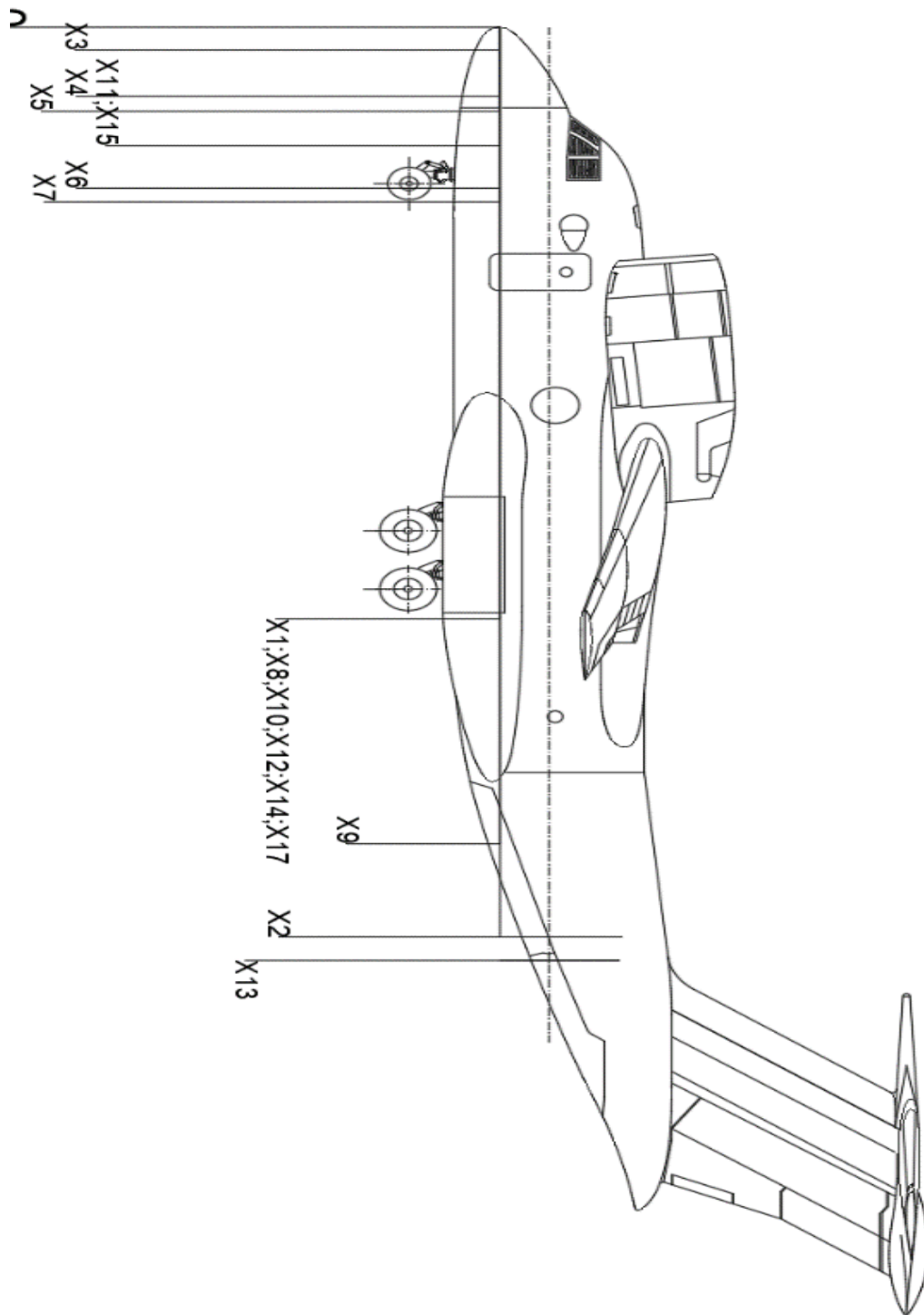

Fig. 1.2 Fuselage components centers of mass

					NAU 20 01A 00 00 00 20 EN	Sheet
Ch.	Sheet	Document No	Signed	Date		23

Part 2. BALL MAT DESIGN FOR PROPOSED AIRCRAFT

2.1. Ball mat principle of work

In these work I represent the aircraft cargo handling ball mat for short take-off and landing cargo aircraft. A ball mat for the loading deck of an aircraft is a known device to support cargo and assist the movement there of.

It works like this: A loader will move a container into the aircraft through one of the large cargo doors. Just inside the door is a ball mat, a device in the floor of the cargo hold that will pull the container all the way in the end then start it on its way to the correct location, where it will be locked in place. The container is moved forwards or backwards by motorized rollers in the floor, the so-called PDUs (Power Drive Units).

Ball mat:

1) are omni-directional load-bearing spherical balls mounted inside a restraining fixture. They are identical in principle to a ball computer mouse upside-down, or a trackball, except there is an array of them side-by-side.

2) Typically the design involves a single large ball supported by smaller ball bearings. They are commonly used in an inverted ball up position where objects are quickly moved across an array of units, known as a ball transfer table, a type of conveyor system. This permits manual transfer to and from machines and between different sections of another conveyor system.

3) Prior to the invention of the ball transfer unit, first patented by Autoset Production Ltd in 1958, these applications were solved by the use of inverted casters. However, casters recognize a trail, meaning that the wheels had to align before directional change could be achieved.

<i>Department of Aircraft Design</i>				<i>NAU 20 01A 00 00 00 20 BM</i>			
<i>Performed by</i>	<i>Artiukh R.V.</i>			<i>Special part</i>	<i>Letter</i>	<i>Sheet</i>	<i>Sheets</i>
<i>Supervisor</i>	<i>Karuskevich M.V.</i>						
<i>Adviser</i>							
<i>Stand.contr.</i>	<i>Khizhnyak S.V.</i>						
<i>Head of Dep.</i>	<i>Ignatovich S.R.</i>						
					<i>AF 402 134</i>		

Ball transfer units can also be used non-inverted ball down position as a type of caster, however this use is restricted by load-bearing limitations and the type of floor.

Compared to purely manual loading, power drive units (PDU) make ground operations more efficient. PDUs add considerable weight to the OEW and require power during ground operations. There are floor mounted and track mounted PDUs. The latter are small enough to fit into trays and are lighter, but have to be provided at a greater numbers.

Quality of rubber coating of the small rollers is essential for satisfactory operation. To allow ULD movement in all directions and rotation necessary in door areas, there are steerable floor-mounted PDUs. Alternatively, a set of PDUs in perpendicular layout can be installed.

A centralized control unit is necessary to ensure efficient and safe operation and only PDUs needed to move ULDs at their actual position are powered. Spacing of PDUs is a tradeoff between the number and weight of all PDUs. Tray mounted PDUs may be spaced wider. If spacing is too wide, badly warped ULDs with bent base edges may stall as PDUs lose contact with the ULDs during transport. In wet conditions, a poor ULD contact with the PDUs may cause conveying difficulties.

Figure 2.1 shows the empty cabin looking aft from the doorway on the right. The cabin can accommodate six cargo pallets or five seat pallets plus one pallet-mounted galley unit. In the foreground is the ball mat which occupies the doorway pallet position and provides for a ninety degree change of direction as pallets are loaded and unloaded. The galley unit is loaded in this doorway position on the ball mat. The cabin floor aft of the doorway comprises four longitudinal roller tracks with six lateral rows of four pallet locks which provide restraint in forward, aft and vertical directions.

					<i>NAU 20 01A 00 00 00 20 BM</i>	<i>Sheet</i>
<i>Ch.</i>	<i>Sheet</i>	<i>Document No</i>	<i>Signed</i>	<i>Date</i>		25



Fig 2.1 Typical Ball mat flooring

2.2. Ball mat design

Nowadays there is no well-known solution for loading cargo in and out of aircraft cargo compartment from door to floor areas. The existing solution for aircraft without significantly sloped doorway floor areas is a doorway area surface referred to as a ball mat.

These allows for the horizontal movement of cargo in all directions. These balls are also called as Ball Transfer Units (BTUs) which are spaced 6 inches from each other. The ball mat is mounted parallel to airplane floor. The main problem of typical rolled mat is that after cargo is in compartment you can not move it or rotate. Rolled floor provides movement only forward and backward directions. In case quick load of cargo is needed ball mat floor is the best decision.

						Sheet
					<i>NAU 20 01A 00 00 00 20 BM</i>	26
Ch.	Sheet	Document No	Signed	Date		

2.3. Calculation of ball mat panel

In designing prototype length and width of cargo compartment were calculated. Using these parameters the ball mat panels are distributed. First of all I choose to install ball mat panel which is meter in length and meter in width. Advantages of this sizing of panel is in placing on aircraft frames and longitudinal beams. In designing short take-off and landing cargo aircraft spars have step 500 mm, so one ball mat plane places on two spars. So area of cargo compartment is equal:

$$S_{c.c.} = L_{c.c.} * W_{c.c.} = 10.5 * 2.15 = 22.57 \text{ (m}^2\text{)}$$

Maximum commercial load of designed aircraft is 7 tons, so using this parameter with area of cargo compartment specific load on floor is equal:

$$P_f = P_c / S_{c.c.} = 7500 / 22.57 = 332,29 \text{ (kg/m}^2\text{)}$$

For ease and practice of calculation I choose square meter panel.

2.4. Determination of ball mechanism type

Taking into account principal importance of weight on aircraft the optimal ball in ball mat panel choice required. Since all ball mat panels have standart balls diameter and materials I choose hi-tech, double seal ball structure 6025-5 from table 2.1

A typically ball mat contains a series of roller balls which have next parameters:

- One inch diameter main spherical balls;
- each one inch ball supported by one-eight inch diameter bearing

Table 2.1 Hi-tech double seal ball transfer units

6025-0	6025-1	6025-2	6025-3	6025-4	6025-5
High load Capacity. Dimensionally compatible with Hevi-Load 7121.	Bolt fixing high load capacity. If used for height adjustment the locknut must remain secured to the body.	Top flange high load capacity. Dimensionally compatible with Hevi-load 7125.	High load capacity. Ball height compatible with Hevi-load 7123.	High load capacity. Coned flange for smoother onoff transfer.	Ideal for shock loading. Stainless steel springs available on request.

The advantages of such ball transfer units are:

- Double sealing. Prevent debris on the bearings appearance;
- The top cover seal removes larger particles;
- the inner knife edge scraper seal skims liquid, paste, fine dust, etc. off the large ball;
- expels liquid, paste, fine dust through side vents;
- a dirt exit hole can also be incorporated;
- chemical resistance. High resistance to organic solvents, petrol and oil;
- temperature. -30°C upto +100°C.

Also choice of a such ball transfer unit explains by materials which are used. The Hi-tech units have glass re-inforced nylon bodies so their weight is less than half that of the Ø25.4mm Heavy-Load units. Scheme of such BTU is shown on figure 2.1.

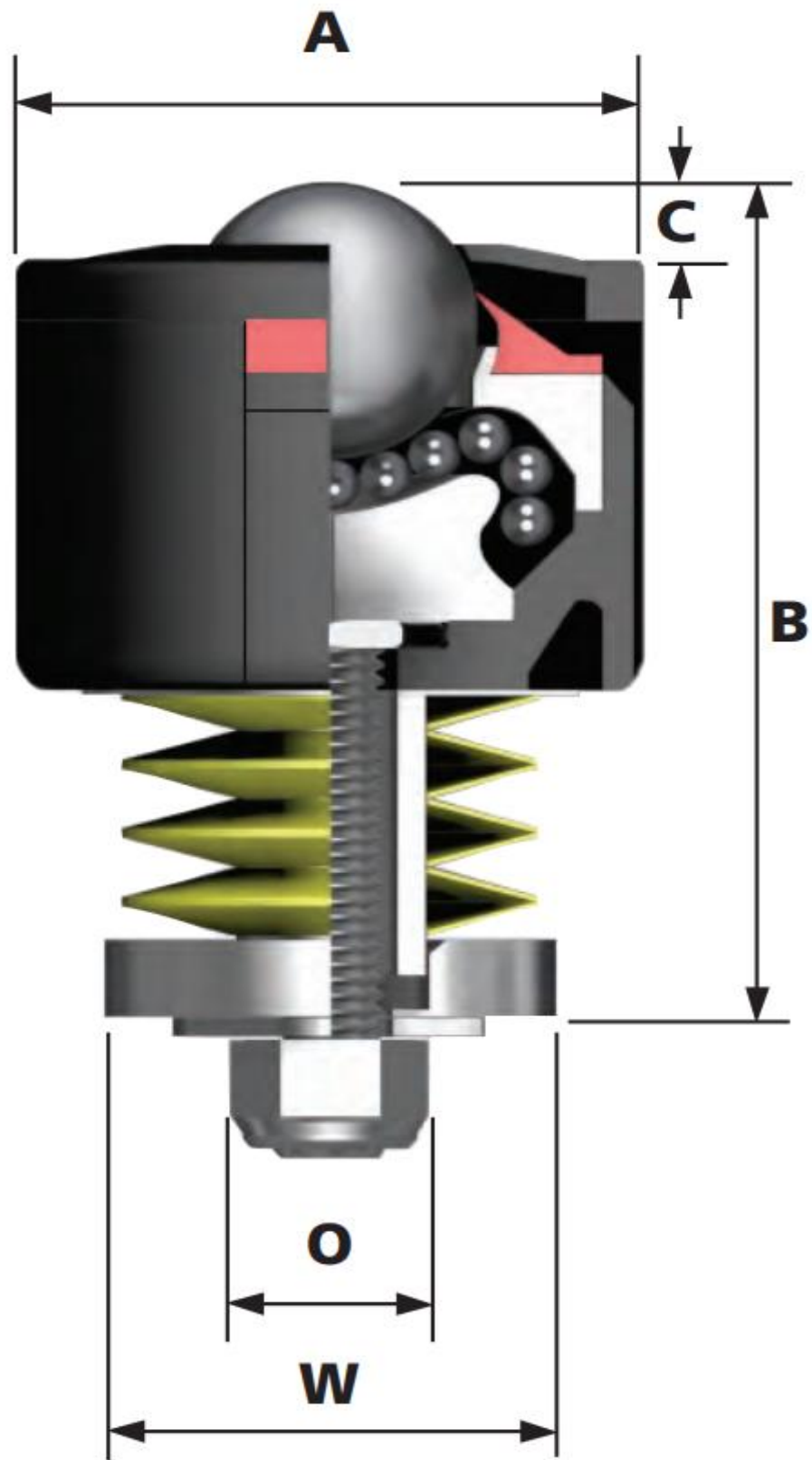

Fig. 2.2 Stainless Steel Spring Double Seal BTU

Ch.	Sheet	Document No	Signed	Date

NAU 20 01A 00 00 00 20 BM

Sheet

29

From the given variants and types of 6025-5 ball transfer units before choosing the load on one ball calculation required. Geometrical parameters and dimensions of such BTUs are represented in table 2.2.

Table 2.2 Geometrical parameters and dimensions of BTUs

Ref no.	Ball size (mm)	Maximum diameter (mm)	Working height of ball (mm)	Collar diameter (mm)	Dynamic support load (kg)
6025-5-13A	25.4	50.8	61.9	38	7
6025-5-13B	25.4	50.8	61.5	38	23
6025-5-13C	25.4	50.8	60.7	38	45
6025-5-13D	25.4	50.8	61.9	38	70
6025-5-13E	25.4	50.8	81.0	38	90
6025-5-13F	25.4	50.8	79.8	38	140
6025-5-13G	25.4	50.8	81.0	38	180
6025-5-13H	25.4	50.8	81.0	38	230

Since BTU panel dimensions are known I choose to distribute 16 BTUs on it. I use typical distance between ball units 200mm. Also calculations are needed to provide equal distances between BTUs on different panels. Distance from center to center is equal:

$$L_c = B_p / n_{BTU} = 1000/4 = 250 \text{ (mm)}$$

Where B_p is width or length of panel and N_{BTU} is numbers of BTU

And again I can not place BTUs to the edges of panel it causes no distance between them at the junction of panels. So the distance from center of BTU to edge is equal:

$$L_e = L_c / 2 = 250 / 2 = 125 \text{ (mm)}$$

Calculated placing of BTUs are represented on figure 2.2.

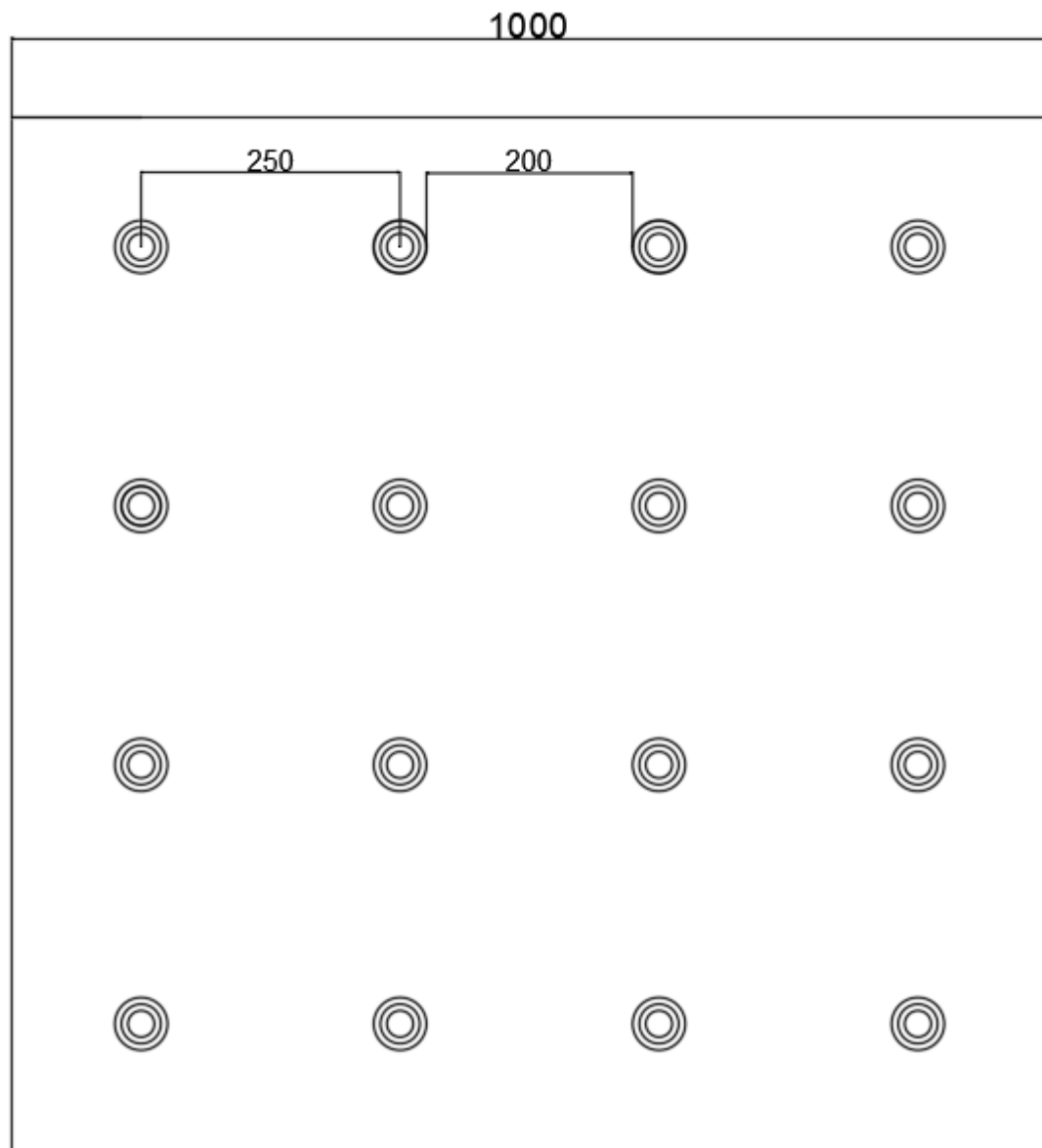

Fig 2.3 BTUs placing on square panel

To avoid unnecessary weight on aircraft by installing ball mat optimal type of BTU should be choose. Since I have specific load on floor value the specific load on one ball is equal:

$$P_{BTU} = P_f / N_{BTU} = 332,29 / 16 = 20.76 \text{ (kg/m}^2\text{)}$$

2.5 Ball Mat Panel installation

Since I know how ball transfer units are distributed i need to install them in panel. Nowadays the best choice is honeycomb composite structure, but it has some features.

A typical honeycomb floor panel consists of:

1. Mat Overlay which provides additional impact and wear protection.
2. Top skin. Carries loads caused by bending. Also provides impact resistance and wear protection.
3. Edge fill. Helps prevent liquid from getting into the panel structure.
4. Core. Light-weight honeycomb structure provides stiffness and strength.
5. Bottom skin. Carries loads caused by bending of the panel.
6. Vibration Dampeners. Reduce vibration and noise travelling through the panels.

Panels are made from honeycomb sandwich panels with carbon – epoxy – glass faces and aramid core. Usually this panels have foam inside to prevent smoke appearance in cabin and to absorb vibrations. Edge fillet prevents liquid from getting into panel structure.

Floor panels can be standard or heavy-duty configurations depending on the applications. In my case I install panels in plane which has heavy big amount of unloading and loading cycles, so heavy-duty panel is the best decision in combination with chosen BTUs.

Advantages of using composite honeycomb floor panel:

- Durability
- Strength
- Stiffness
- Impact and crush-resistance
- Shear strength
- Flammability resistivity properties

					NAU 20 01A 00 00 00 20 BM	Sheet
Ch.	Sheet	Document No	Signed	Date		32

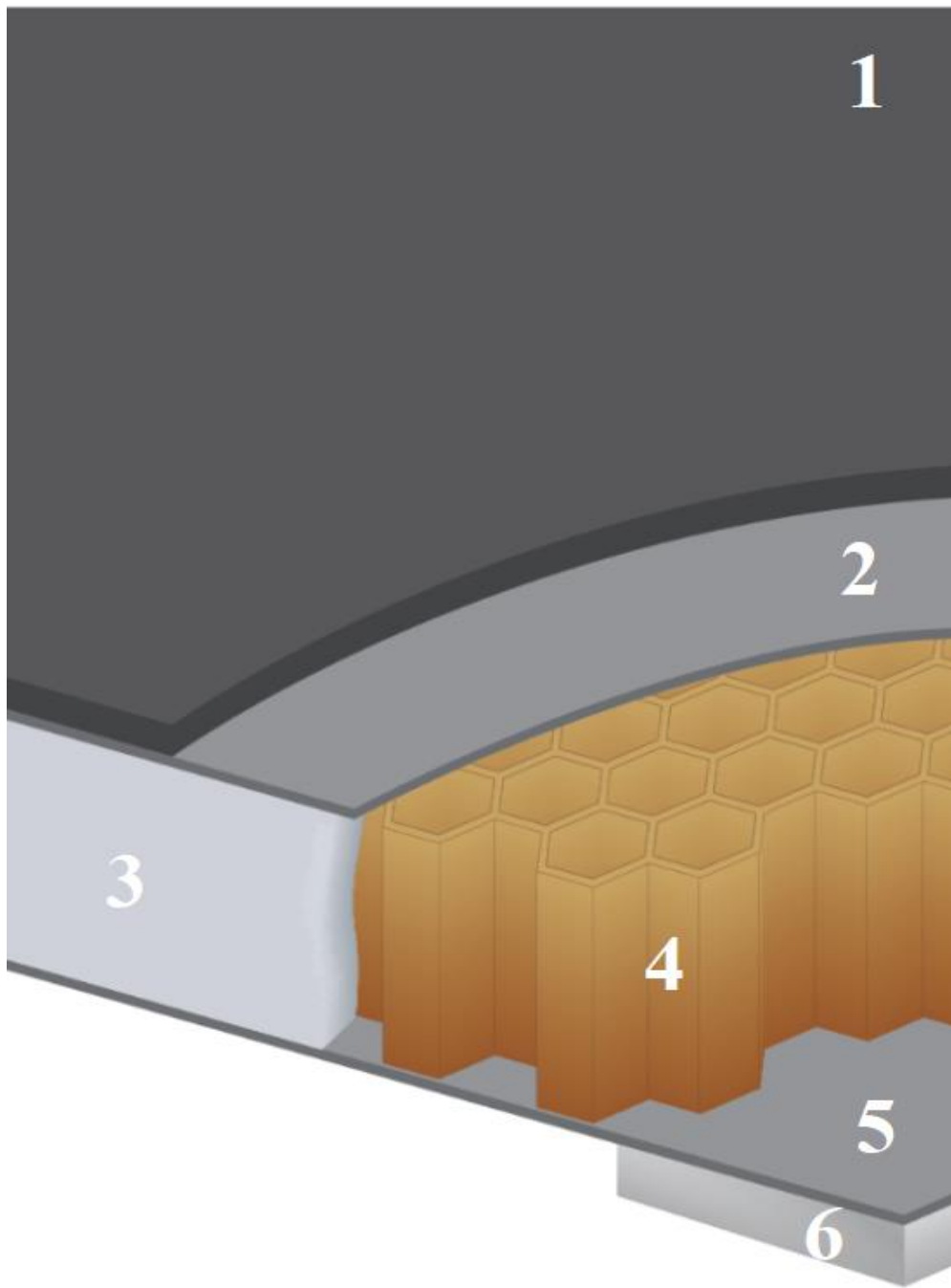

Fig. 2.4 A typical honeycomb composite floor panel

General conclusions

The preliminary design presented in the first part of the diploma paper comprises results of new aircraft synthesis on the base of known successful machines and calculation procedures.

During this designing work the following results have been achieved:

- the geometrical and mass parameters have been selected;
- the mass of main aircraft components have been calculated;
- the engine for the required power has been selected;
- the landing gear parameters have been found;
- the range of the center of gravity of the airplane has been determined.

The chosen design of high wing aircraft with two engines, which are located on wing, makes it possible to increase aerodynamic characteristics of the wing, to use the aerodynamic effects from engines jet stream and to increase lift power.

Due to calculation of ball mat was performed the optimal type of ball transfer unit has selected. This makes aircraft loading and unloading more easy, without huge additional weight.

*Department
of Aircraft Design*

NAU 20 01A 00 00 00 20 EN

<i>Performed by</i>	<i>Artiukh R.V.</i>			<i>Conclusions</i>	<i>Letter</i>	<i>Sheet</i>	<i>Sheets</i>
<i>Supervisor</i>	<i>Karuskevich M.V.</i>						
<i>Adviser</i>					<i>AF 402 134</i>		
<i>Stand.contr.</i>	<i>Khizhnyak S.V.</i>						
<i>Head of Dep.</i>	<i>Ignatovich S.R.</i>						

References

1. 14 CFR Part 25 – Airworthiness standards: transport category airplanes
<https://www.law.cornell.edu/cfr/text/14/part-25>
2. Karuskevich M. V., Maslak T.P. «Design of aviation machines. Modern regional turboprop». Lecture outline. – K.: NAU, 2007. – 60.
3. Karuskevich M.V., Maslak T.P. «Aircraft. Design». Lectures course for the students of speciality 6.070102 «Aeronavigation». – K.:NAU, 2013. – 176 p.
4. Попов А.В., Шпакович Н.И., Маслак Т.П. Методические рекомендации по выполнению дипломных работ (проектов) для студентов специальности 272 «Авиационный транспорт» специализации «Техническое обслуживание и ремонт воздушных судов и авиадвигателей». – К.: НАУ, 2017. – 56с.
5. Житомирский Г.И. Конструкция самолетов: Учебник для студентов авиационных специальностей ВУЗов. – М.: Машиностроение, 1991. – 400 с.
6. Гаража В.В. Конструкция самолетов: Учебник для студентов авиационных специальностей ВУЗов. – К.: КМУГА, 1998. – 524 с.
7. Проектирование самолетов: учебник для вузов / под ред. С. М. Егера. – 3-е изд., перераб. и доп. – М.: Машиностроение, 1983. – 616 с.
8. Конструкція та міцність літальних апаратів (частини 1,2): методичні рекомендації до виконання курсового проекту для студентів спеціальності 134 «Авіаційна та ракетно-космічна техніка»/уклад.: С.Р. Ігнатович, М.В. Карускевич, Т.П. Маслак, С.В. Хижняк, С.С. Юцкевич. – К.: НАУ, 2018. – 139 с.

<i>Department of Aircraft Design</i>				<i>NAU 20 01A 00 00 00 20 EN</i>			
<i>Perform by</i>	<i>Artiukh R.V.</i>			<i>References</i>	<i>Letter</i>	<i>Sheet</i>	<i>Sheets</i>
<i>Supervisor</i>	<i>Karuskevich M.V.</i>						
<i>Stand.contr</i>	<i>Khizhnyak S.V.</i>				<i>AF 402 134</i>		
<i>Head of dep.</i>	<i>Ignatovich S.R</i>						