

**MINISTRY OF EDUCATION AND SCIENCE OF UKRAINE  
NATIONAL AVIATION UNIVERSITY  
DEPARTMENT OF AIRCRAFT DESIGN**

**APPROVED BY**

Head of department

Dr. of Sc., professor

\_\_\_\_\_ S.R. Ignatovich

«\_\_\_\_» \_\_\_\_\_ 2020

**MASTER THESIS**

**ON SPECIALITY**

**“AVIATION AND SPACE ROCKET TECHNOLOGY”**

**Theme: «Concept of a smart bin in a passenger aircraft»**

**Prepared by:** \_\_\_\_\_ E. Michael

**Supervisor:**  
PhD, associate professor \_\_\_\_\_ T. Maslak

**Advisers:**  
**Labor protection:**  
PhD, associate professor \_\_\_\_\_ O. Konovalova

**Environmental protection:**  
PhD, associate professor \_\_\_\_\_ L. Pavliukh

**Standard inspector**  
PhD, associate professor \_\_\_\_\_ S. Khizhnyak

**Kyiv 2020**

# NATIONAL AVIATION UNIVERSITY

Aerospace Faculty  
Department of Aircraft Design  
Master's degree  
Specialty 134 "Aviation and space rocket technology"  
Educational professional program «Aircraft Equipment»

**APPROVED BY**  
Head of Department  
Dr. of Sciences, Prof.  
\_\_\_\_\_ S.R. Ignatovich  
«\_\_\_\_\_» \_\_\_\_\_ 2020

## TASK

**for the master thesis**

ELENWOKE MICHAEL

1. Topic: **«Preliminary design of smart storage bins for passenger aircraft»**, approved by the order of the Rector of October 5, 2020 № 1906/CT.
2. Thesis term: from 5.10.2020. to 13.12.2020.
3. Initial data: statistic data of prototypes, cruise speed of designing plane 850 km/hour, flight range 5500 km, 250 number of passengers
4. Contents of the explanatory note: analysis of current trends in passenger cabin design, preliminary design of mid-range passenger aircraft, smart bin design
5. The list of illustrative material: placards illustrated the results of storage bin design, drawings of the passenger aircraft general view and cabin layout.

All graphical materials are performed by CATIA, AutoCad

## 6. Thesis schedule

№	Task	Time limits	Done
1	Task receiving, processing of statistic data of prototypes	5.10.2020–8.10.2020	
2	Literature review	9.10.2020–15.10.2020	
3	Initial data calculation for designing plane	16.10.2020–17.10.2020	
4	Geometrical calculations, aircraft layout, center of gravity calculation	18.10.2020–25.10.2020	
5	Storage bin design	25.10.2020–29.10.2020	
6	Execution of the parts, devoted to environmental and labor protection	30.10.2020–5.11.2020	
7	Preparation of illustrative material, writing the report	5.11.2020–20.11.2020	
8	Completion of the explanatory note	21.11.2020–05.12.2020	

## 7. Special chapter consultants

Chapter	Consultants	Date, signature	
		The task issued	Task accepted
Labor protection	PhD, assoc. prof. O. Konovalova		
Environmental protection	PhD, assoc. prof. L. Pavliukh		

Date: 5.10.2020 year

Supervisor \_\_\_\_\_ T. Maslak

Student \_\_\_\_\_ E. Michael

## **ABSTRACT**

Master degree thesis “conceptual design of a smart storage bin in a passenger aircraft”

97p, 4 drawings, 22fig, 15 tables, 21 references

Object of study: sensors and storage equipment of a passenger aircraft, taking into account Boeing 767.

Subject of study: smart storage bin in a passenger aircraft.

Aim of master thesis: is to design a smart storage bin for a passenger aircraft

Research and development methods: analyzing the requirements of a storage bin, taking into account the preliminary design of the plane. For this project Load sensors are connected to each passenger storage bin and provide an output signal proportional to a weight of items within the bin. The range sensors are also coupled to each passenger storage bin and provide an output signal proportional to an amount of empty space available within the bin. Analyzing the smart sensor system for the plane, considering the labor and environmental factors of design and production.

Novelty of results: it is the first time a smart bin will be successfully designed and implemented in a passenger aircraft.

Practical value: it will improve the safety onboard a passenger aircraft by indicating a full storage bin to avoid fall. It also will save time for passengers when boarding and existing the aircraft to know which storage facility to use at each point in time. The display device provides a visual indication based upon such status signal whether or not the associated storage bin is filled.

**AIRCRAFT, PRELIMINARY DESIGN, LAYOUT, CENTER OF GRAVITY  
POSITON, DESIGN OF SMART STORAGE BIN**

## **ABBREVIATIONS**

LED – light emitting diode

CD- Compact disc

BPA – Bisphenol A

PVC- Polyvinyl chloride

PET- Polyethylene terephthalate

IATA – International Air Transport Association

FAA- Federal aviation authority

## **CONTENT**

INTRODUCTION.....	11
PART 1 STATE OF THE ART LITERATURE REVIEW.....	13
1.1 General requirements of a storage bin in a plane.....	13
1.2 Current trends in storage bin design .....	14
1.3 Storage bin design enhancements to improve retention .....	17
Conclusion to part 1.....	20
PART 2 PRELIMINARY DESIGN OF A LONG-RANGE PASSENGER PLANE ..	21
2.1. Geometry calculations for the main parts of the aircraft.....	23
2.1.1 Wing geometry calculation.....	24
2.1.2 Fuselage layout.....	28
2.1.3 Luggage compartment.....	30
2.1.4 Galleys and buffets.....	31
2.1.5 Lavatories.....	31
2.1.6 Layout and calculation of basic parameters of tail unit.....	32
2.1.7 Landing gear design.....	34
2.1.8 Choice and description of power plant.....	36
2.2 Determination of centering of the equipped wing.....	37
2.2.2 Determination of the centering of the equipped fuselage.....	38
2.2.3 Calculation of center of gravity positioning variant.....	42
Conclusion to part 2.....	43
PART 3 CONCEPTUAL DESIGN OF A SMART STORAGE BIN.....	45
3.1 Analysis of storage bin operation.....	45
3.2 Detailed description of storage bin design .....	49
3.3 smart storage bin system analysis of operation.....	54
3.4 Calculation for strength of overhead storage bin bottom part.....	61
Conclusion to part 3.....	66
PART 4 LABOR PROTECTION.....	67
4.2 Analysis of the working conditions.....	67

4.2.1 Organizing the workspace of the engineer.....	67
4.2.2 Harmful and dangerous factors list.....	68
4.2.3 Harmful and dangerous factors analysis.....	68
4.2.4 The Artificial lighting calculation.....	71
4.3 General production safety requirements in equipment design and production of equipment.....	73
4.4 Safety requirements before starting work.....	73
4.5 General safety requirements during production of equipment.....	74
4.6 Safety requirements after production .....	75
4.7. Safety requirements at emergency situations during production.....	75
Conclusion to part 4.....	77
<b>PART 5 ENVIRONMENTAL PROTECTION.....</b>	<b>78</b>
5.1 Utilization of plastics as materials.....	78
5.2 The effect of plastic debris on environment and wildlife.....	80
5.3 The effect of plastic in our natural environment.....	82
5.4 production, usage, waste management solutions.....	85
5.5 Biopolymers, degradable and non-degradable biopolymers solutions.....	89
5.6 Policy measures.....	91
Concision of part 5.....	95
<b>GENERAL CONCLUSION.....</b>	<b>96</b>
<b>REFERENCES.....</b>	<b>97</b>

## INTRODUCTION

This project work is on the smart bin implementation in a passenger aircraft. We would be analyzing the design and production of a smart storage bin in a long range passenger aircraft.

The Airplane turn time (the time required to unload an airplane after its arrival at the gate and to prepare it for departure again) has increased since the mid-1970s. This contributes to both flight delays and increased passenger frustration. One of the key elements of turn time in a single-aisle aircraft is passenger boarding. One factor that contributes to an increase in passenger boarding time is an increase in the amount of passenger carry-on luggage. Passengers have increased their carry-on baggage for a number of reasons, including the implementation of checked baggage fees by the airlines. During the boarding process, finding available overhead bin storage space for carry-on baggage becomes increasingly time consuming and frustrating for passengers and flight attendants, and can cause delayed departure.

Airlines and aircraft manufacturers have attempted to address boarding delays in a number of ways. For example, airlines have modified the order of passenger boarding, but studies have shown that new boarding algorithms have proven largely ineffective in reducing boarding time. Airlines and manufacturers have also changed the size and shape of overhead bin storage space to make the space more usable, but because this option is limited by space constraints this has also been found ineffective in reducing boarding time.

Accordingly, there is a need for an improved system which assists in speeding the aircraft boarding process.

A system for monitoring an overhead storage bin includes a proximity sensor, a load sensor, a latch mechanism sensor, and a controller operatively connected to the proximity sensor, the load sensor and the latch mechanism sensor. The controller is configured to retrieve proximity data from the proximity sensor indicative of a space status of an overhead storage bin, retrieve load data from the load sensor indicative of a stowage weight status of



the bin, and retrieve a latch status from the latch mechanism indicative of a latch status of an access door of the bin. The controller is further configured to determine, based on the space status, the weight data, and the latch status, a probability indicative of whether an item stowed in the bin may fall from the bin, and output, based on the probability, an indication on an output device on an exterior surface of the bin.

# **PART 1**

## **STATE OF THE ART LITREATURE REVIEW**

### **1.1 General requirements of a storage bin in a passenger plane**

The IATA Baggage Services Manual contains information on the rules and industry-accepted procedures relating to the carriage of baggage:

For the purposes of this publication, the term “carry-on baggage” is synonymous with unchecked baggage, hand baggage and cabin baggage, and the terms are used interchangeably.

All cabin baggage must be securely stowed. Accident reports indicate that the presence of excess cabin baggage can be a significant factor affecting passenger survival in accident situations. Unsecured baggage can be dislodged and become a projectile during accidents and severe turbulence. It can also obstruct evacuation routes and exits, where it can delay the evacuation of passengers and crew. All airlines and manufacturers should ensure that sufficient adequately designed cabin storage facilities are provided on all passenger aircraft.

Consideration should be given to weight, volume and aircraft type. All carry-on passenger baggage that cannot be stowed or does not conform to regulations should not be carried in the cabin and should be checked.

Baggage Allowance Carry-on baggage should be stowed in the aircraft cabin which limits baggage to a size, weight and shape that fits under a passenger seat or in a storage compartment. Cabin baggage should have a maximum length of 22 inches (56 cm), width of 18 inches (45 cm) and depth of 10 inches (25 cm)

These dimensions include wheels, handles, side pockets, etc. Carry-on items must remain with the passenger at all times and are the responsibility of the passenger. Cabin crew should be encouraged to be vigilant during the boarding phase to ensure that all carry-on baggage conforms to the airline’s regulations and that carry-on baggage is properly

tagged and stowed. Ground staff should also monitor cabin baggage during the check in and boarding process and not allow deviations from the airline's standards.

No certificate holder may allow the boarding of carry-on baggage on an airplane unless each passenger's baggage has been scanned to control the size and amount carried on board in accordance with an approved carry-on baggage program in its operations specifications. In addition, no passenger may board an airplane if his/her carry-on baggage exceeds the baggage allowance prescribed in the carry-on baggage program in the certificate holder's operations specifications

## **1.2 Current trends in storage bin design**

Overhead stowage bins were never designed to replace the checking of baggage for transport in the cargo compartment of the airplane. In fact, early airplane models, such as the 707, 727, and 737, provided a limited overhead stowage. These appropriately named "hat racks" were limited to stowing emergency equipment and soft items such as coats, hats, blankets, and pillows.

But as the type and quantity of passenger carry-on baggage evolved, so did stowage bin designs. Stowage bin capacities have increased, and the designs have changed to better accommodate the sizes and geometry of carry-on baggage.

Currently, there are three types of overhead stowage bins: shelf, pivot, and translating bins. Individual bin size generally is determined by the length of the airplane, interior arrangement, carry-on baggage requirements, and the spacing of the body frames to which the bins are attached. Standard shelf bins range in length from 15 to 88 in. Standard pivot and translating bins are 15 to 44 in long.

The shelf bin is the most common design fig. 1(<http://www.boeing.com/1>). Its door opens outward and up. It is most often found as an outboard overhead stowage bin on older interior designs delivered on both single-aisle and twin-aisle airplanes. The pivot and translating bin designs have a controlled rate of opening and provide good visibility during opening and closing because the door opens out and down. Pivot and translating bins are

common on both single-aisle and twin-aisle airplanes. Stowage bin designs have evolved over the years and depend on the available space within the airplane the following page summarizes the types of stowage bins available by airplane model. The maximum load capability of each stowage bin is identified on load-limit placards displayed on the interior surface of each stowage bin.

Early derivatives of twin-aisle airplanes typically used the pivot or translating bins for the center or inboard overhead stowage bins, and shelf bins for the outboard overhead stowage bins. MD-11 airplanes, however, were offered with two overhead bin configurations. Some used a translating or articulating center overhead stowage bin, while others used a center shelf bin. Newer twin-aisle airplanes such as the 777 and 767-400 have a more open interior aesthetic design that uses outboard pivot bins and inboard or center translating bins.

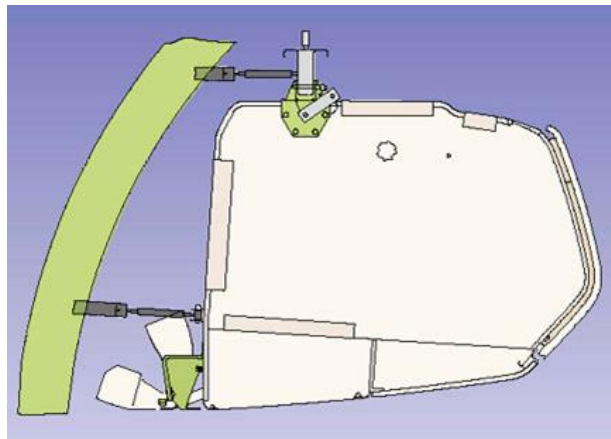

Figure 1.1 – Outboard overhead shelf bin design in closed position

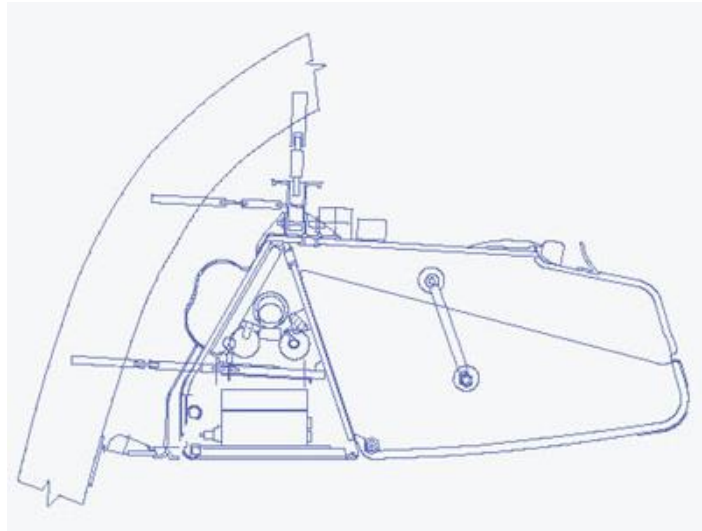

Figure 1.2 - Outboard overhead pivot bin design in closed position

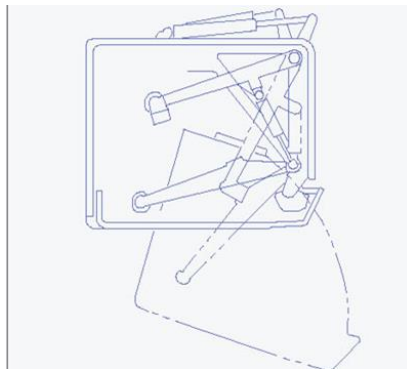

Figure 1.3 – Centre overhead translating bin

Airplane model	Bin system
717	Outboard shelf
737-300/-400/-500	Outboard shelf
737-600/-700/-800/-900	Outboard shelf
747-100/-200	Outboard pivot
	Center pivot
747-300	Outboard shelf
	Outboard pivot (zone A)
	Center pivot
747-400	Outboard shelf
	Outboard pivot (zone A)
	Outboard pivot optional (zone B)
	Center pivot
757	Outboard shelf
767-200/-300	Outboard shelf shallow
	Outboard shelf deep
	Center translating
767-400 new-look interior	Outboard pivot
	Center pivot
777-200/-300	Outboard pivot
	Center translating
DC-9	Outboard shelf
MD-11	Outboard shelf
	Center shelf
	Center translating
MD-80 contemporary deep-rack interior/ extended spatial concept interior	Outboard shelf
	Outboard shelf
MD-90 extended spatial concept interior	Outboard shelf

Figure 1.4 – Overhead bin systems by airplane model

### 1.3 Storage bin design enhancements to improve retention

Even if an overhead storage bin is properly loaded before takeoff, it is possible that items removed during flight may not be properly reloaded. An improperly loaded overhead storage bin has a higher probability of becoming unstable during routine flight maneuvers than does a properly loaded bin.

To address this issue, Boeing incorporated a variety of overhead storage bin enhancements to reduce the risk of carry-on items becoming dislodged when the overhead storage bin door is opened. The design enhancements include warning placards and secondary restraint devices.

The 6- by 1.25-in placards are posted on the front of the storage bins to increase passengers' awareness that carry-on items may have shifted during flight.



Figure 1.5 – Overhead storage bin warning placard

Another design enhancement is the installation of secondary restraint devices on shelf bins such as secondary doors or visors, nets, and deflector panels and thresholds. The secondary door or visor system consists of a set of two secondary doors or visors per bin, which remains in the closed position when the primary bin door is opened (fig.6. <http://www.boeing.com/>) The visors have open viewing ports with flexible nets installed over the ports. After opening the primary bin door, the visor allows a person to observe the bin contents and take necessary action if an item has the potential for falling when the visor is opened. Parts are currently available for many 737, 747, and 757 applications.

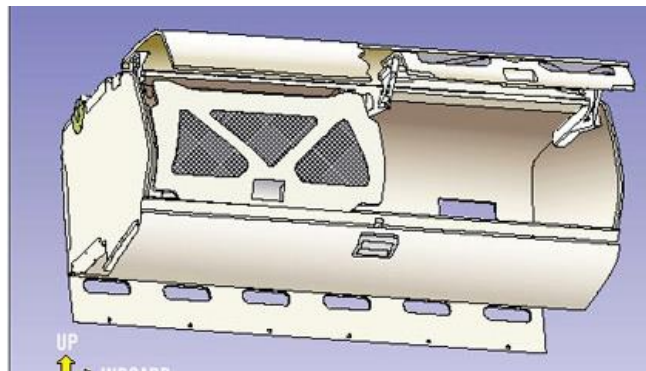

Figure 1.6 – Outboard overhead shelf bin with a visor system installed

Another type of secondary restraint system is a net system for use on 727 and 767 airplanes. This system, developed by Ansett Australia, Melbourne, consists of a weave of elastic straps sewn together to form a net. The net mechanically fastens to the inside of the stowage bin and covers approximately the lower half of the stowage bin opening. With the

primary stowage bin door in the open position, baggage items maybe loaded and unloaded by displacing the elastic netting

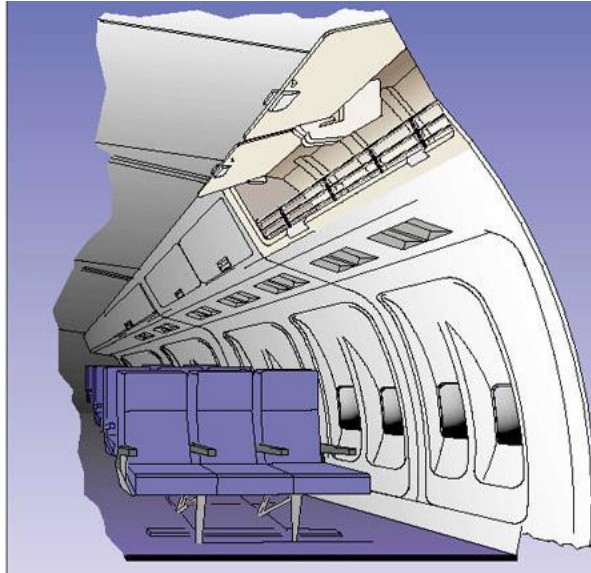

Figure 7. outboard overhead shelf bin with a net system



## **Conclusion to part 1**

In this part I analyzed the different trends of a storage bin in a passenger aircraft, taking into account the plane models and various storage types and capacity, furthermore into the project the prototype of a Boeing 767 will be considered for the implementation of a smart storage bin for proper air safety and management.

In my opinion the current trends currently designed storage bins have no way of indicating if full or not and that most times causes flight delays during takeoff, implementing the smart storage bin designs will not only ensure faster flight trips but also ensure safety of the passengers on board

## PART 2

### PRELIMINARY DESIGN OF A LONG-RANGE PASSENGER AIRCRAFT

The subject of my diploma was the preliminary design of a long range aircraft that can transport, 200-300 passengers with modification to the storage compartment for the possibility of installing smart storage bins.

Prototypes of the aircraft, taking for the designing of the plane were in the class of 200-300passengers of the Boeing 767 family, various variants of the prototypes and its specifications are listed in the table 1 below .

Table 2.1 –Specifications of various Boeing 767 aircrafts

Variant	767-200	767-200ER	767-300	767-300ER/F	767-400ER
Cockpit crew	Two				
3-class seats	174 (15F, 40J, 119Y)		210 (18F, 42J, 150Y)		243 (16F, 38J, 189Y)
2-class seats	214 (18J, 196Y)		261 (24J, 237Y)		296 (24J, 272Y)
1- class(limit)	245Y (290)		290Y (351)		409Y (375)
Cargo	3,070 ft <sup>3</sup> / 86.9 m <sup>3</sup>		4,030 ft <sup>3</sup> / 114.1 m <sup>3</sup>		4,905 ft <sup>3</sup> / 138.9 m <sup>3</sup>
ULD	22 LD2s		30 LD2s		38 LD2s
Length	159 ft 2 in / 48.51 m		180 ft 3 in / 54.94 m		201 ft 4 in / 61.37 m
Wingspan	156 ft 1 in / 47.57 m				170 ft 4 in / 51.92 m
Wing	3,050 ft <sup>2</sup> / 283.3 m <sup>2</sup> , 31.5° sweepback				3,130 ft <sup>2</sup> / 290.7 m <sup>2</sup>
Fuselage	Exterior: 17 ft 9 in / 5.41 m height, 16 ft 6 in / 5.03 m width; <sup>1</sup> Cabin width: 186 in/ 4.72 m				

Continuation of table 2.1

MTOW	315,000 lb / 142.9 t	395,000 lb / 179.2 t	350,000 lb / 158.8 t	412,000 lb / 186.9 t	450,000 lb / 204.1 t
Max. payload	73,350 lb (33.3 t)	78,390 lb (35.6 t)	88,250 lb (40.0 t)	96,560 lb (43.8 t)	101,000 lb (45.8 t)
OEW	176,650 lb / 80.1 t	181,610 lb / 82.4 t	189,750 lb / 86.1 t	198,440 lb / 90.0 t	229,000 lb / 103.9 t
Fuel capacity <sup>1</sup>	std-ER: 16,700-24,140 US gal / 63.2-91.4 m <sup>3</sup> (111,890-161,740 lb / 50.8-73.4 t)				
Range	3,900 nmi 7,200 km	6,590 nmi 12,200 km	3,900 nmi 7,200 km	5,980 nmi 11,070 km	5,625 nmi 10,415 km
Cruise speed	Long range-Maximum: 459–486 kn (850–900 km/h) at altitude of 39,000 ft (12,000 m)				
Ceiling	43,100 ft (13,100 m)				
Takeoff	6,300 ft (1,900 m)	2,480 m / 8,150 ft	9,200 ft (2,800 m)	2,650 m / 8,700 ft	3,290 m / 10,800 ft
Engines (×2)	JT9D / PW4000 / CF6	JT9D / PW4000 / CF6 / RB211		PW4000 / CF6 / RB211	CF6 / PW4000
Thrust (×2)	48,000–52,500 lbf 214–234 kN	48,000–60,600 lbf 214–270 kN	48,000–60,600 lbf 214–270 kN	56,750–61,500 lbf 252–274 kN	60,600 lbf 270 kN

To ensure the even distribution of the aircraft's weight on the ground, the 767 has a retractable tricycle landing gear with four wheels on each main gear and two for the nose gear. The original wing and gear design accommodated the stretched 767-300 without major changes. The 767-400ER features a larger, more widely spaced main gear with 777 wheels, tires, and brakes. To prevent damage if the tail section contacts the runway surface during takeoff, 767-300 and 767-400ER models are fitted with a retractable tailskid. The 767 has left-side exit doors near the front and rear of the aircraft.

In addition to shared avionics and computer technology, the 767 uses the same auxiliary power unit, electric power systems, and hydraulic parts as the 757. A raised

cockpit floor and the same forward cockpit windows result in similar pilot viewing angles. Related design and functionality allows 767 pilots to obtain a common type rating to operate the 757 and share the same seniority roster with pilots of either aircraft.

The 767 is equipped with three redundant hydraulic systems for operation of control surfaces, landing gear, and utility actuation systems. Each engine powers a separate hydraulic system, and the third system uses electric pumps. A ram air turbine provides power for basic controls in the event of an emergency. An early form of fly-by-wire is employed for spoiler operation, utilizing electric signaling instead of traditional control cables. The fly-by-wire system reduces weight and allows independent operation of individual spoilers. The 767 features a twin-aisle cabin with a typical configuration of six abreast in business class and seven across in economy. The standard seven abreast, 2–3–2 economy class layout places approximately 87 percent of all seats at a window or aisle. As a result, the aircraft can be largely occupied before center seats need to be filled, and each passenger is no more than one seat from the aisle. It is possible to configure the aircraft with extra seats for up to an eight abreast configuration, but this is less common.

The 767 interior designers introduced larger overhead bins and more lavatories per passenger than previous aircraft. The bins are wider to accommodate garment bags without folding, and strengthened for heavier carry-on items. A single, large galley is installed near the aft doors, allowing for more efficient meal service and simpler ground resupply. Passenger and service doors are an overhead plug type, which retract upwards, and commonly used doors can be equipped with an electric-assist system.

## **2.1. Geometry calculations for the main parts of the aircraft**

Layout of the aircraft consists from composing the relative disposition of its parts and constructions, and all types of the loads (passengers, luggage, cargo, fuel, and so on).

Choosing the scheme of the composition and aircraft parameters is directed by the best conformity to the operational requirements.

### 2.1.1 Wing geometry calculation

Geometrical characteristics of the wing are determined from the take off weight  $m_0$  and specific wing load  $P_0$ .

Full wing area with extensions is:

$$S_{wfull} = \frac{m_0 \cdot g}{p_0} = \frac{33076 \cdot 9.8}{4480} = 286 [m^2]$$

Relative wing extensions area is 0.1.

Wing area is:

$$S_w = 286 \cdot 0,9 = 286 [m^2]$$

Wing span is:

$$l = \sqrt{S_w \cdot \lambda} = \sqrt{286,16 \cdot 7.86} = 47.5 [m]$$

Root chord is:

$$b_o = \frac{2S_w \cdot \eta_w}{(1 + \eta_w) \cdot l} = \frac{2 \cdot 120,13 \cdot 3,3}{6 \cdot 47.5} = 10(m)$$

Tip chord is:  $b_t = \frac{b_o}{\eta_w} = \frac{10}{5} = 2(m)$

Taper Ratio:

$$\eta_w = \frac{b_o}{b_t} = \frac{10}{2} = 5$$

Maximum wing width is determined in the forehead i-section and by its span it is equal:

$$C_i = \bar{c} \times b_i = 0,13 \times 2 = 0,26 [m]$$

On board chord for trapezoidal shaped wing is:

$$b_{ob} = b_0 \times \left( 1 - \frac{(\eta_w - 1) \times D_f}{\eta_w \times l_w} \right) = 10 \times \left( 1 - \frac{(5 - 1) \times 5}{5 \times 47.5} \right)$$

$$= 9.16 [m]$$

At a choice of power scheme of the wing we determine quantity of spars and its position, and the places of wing portioning.

On the modern aircraft we use torsion box wing. Our aircraft has three spars.

Relative position of spars in wing by chord:

$$\bar{x}_i = \frac{x_i}{b}$$

In wing with two spars  $\bar{x}_1 = 0,2$ ;  $\bar{x}_2 = 0,6$ .

I use the geometrical method of mean aerodynamic chord determination (figure 2.1).

Mean aerodynamic chord is equal:  $b_{MAC} = 6.89 [m]$

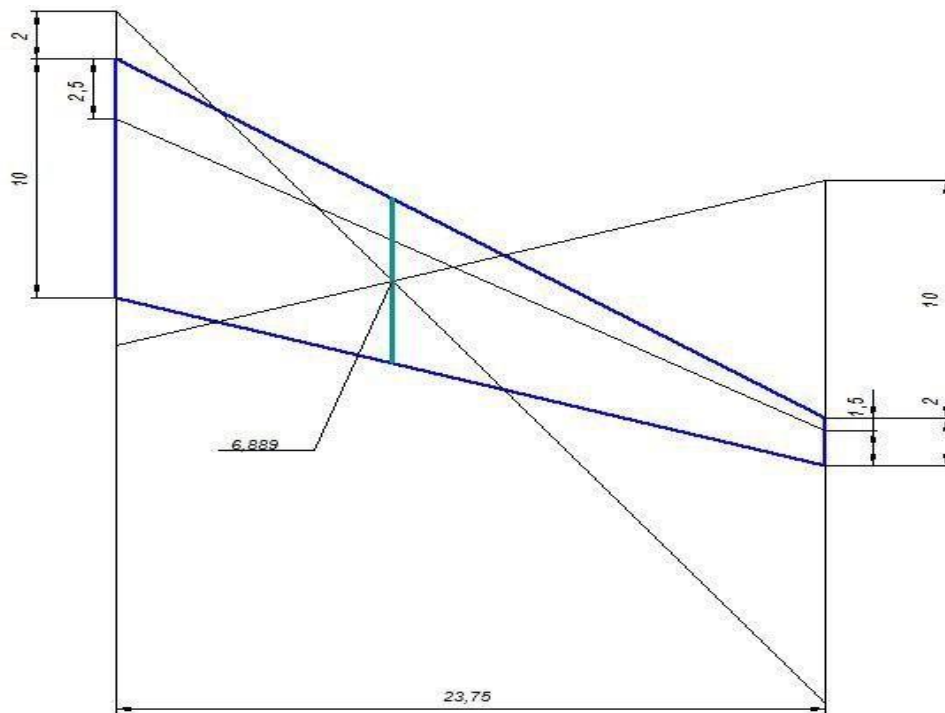

Figure 2.1. – Determination of mean aerodynamic chord

After determination of the geometrical characteristics of the wing we come to the estimation of the ailerons geometrics and high-lift devices.

Ailerons geometrical parameters are determined in next consequence:

Ailerons span

$$l_{ail} = 0,35 \times \frac{l_w}{2} = 0,35 \times \frac{47.5}{2} = 5.7 [m]$$

Chord of aileron:

$$C_{ail} = 0,023 \times b_i = 0,023 \times 2 = 0,046 [m]$$

Aileron area:

$$S_{ail} = 0,022 \times \frac{S_w}{2} = 0,022 \times \frac{286}{2} = 3.14 [m^2]$$

Increasing of  $l_{ail}$  and  $b_{ail}$  more than recommended values is not necessary and convenient. With the increase of  $l_{ail}$  more than given value the increase of the ailerons coefficient falls, and the high-lift devices span decreases. With  $b_{ail}$  increase, the width of the xenon decreases.

In the airplanes of the third generation there is a tendency to decrease relative wing span and ailerons area. So,  $l_{ail} = 0.122$ . In this case for the transversal control of the airplane we use spoilers together with the ailerons. Due to this the span and the area of high-lift devices may be increased, which improves take off and landing characteristics of the aircraft.

Aerodynamic balance of the aileron.

Axial balance:

$$S_{axinail} \leq (0.25...0.28) S_{ail} = 0,27 \times 3,087 = 0,833 [m^2]$$

Inner axial balance

$$S_{inaxinail} = (0.3..0.31) S_{ail} = 0,3 \times 3,087 = 0,926 [m^2]$$

Area of ailerons trim tab.

For two engine airplane:

$$S_{tr.ail} = 0,05 \times S_{ail} = 0,05 \times 3,087 = 0,15435 [m^2]$$

Range of aileron deflection

Upward  $\delta'_{ail} \geq 25$ ;

Downward  $\delta''_{ail} \geq 15^\circ$ .

The aim of determination of wing high-lift devices geometrical parameters is the providing of take off and landing coefficients of wing lifting force, assumed in the previous calculations with the chosen rate of high-lift devices and the type of the airfoil profile.

Before doing following calculations it is necessary to choose the type of airfoil due to the airfoil catalog, specify the value of lift coefficient  $C_{y_{max}bw}$  and determine necessary increase for this coefficient  $C_{y_{max}}$  for the high-lift devices outlet by the formula:

$$\Delta C_{y_{max}} = \left( \frac{C_{y_{max}l}}{C_{y_{max}bw}} \right)$$

Where  $C_{y_{max}l}$  is necessary coefficient of the lifting force in the landing configuration of the wing by the aircraft landing insuring (it is determined during the choice is the aircraft parameters).

In the modern design the rate of the relative chords of wing high-lift devices is:

$b_{sf} = 0.25..0.3$  – for the split edge flaps;

$b_f = 0.28..0.3$  – one slotted and two slotted flaps;

$b_f = 0.3..0.4$  – for three slotted flaps and Faylers flaps;

$b_s = 0.1..0.15 \times b_l = 0.1 \times 1,75 = 0,175$  – slats.

Effectiveness of high-lift devices rises proportionally to the wing span increase, serviced by high-lift devices, so we need to obtain the biggest span of high lift devices due to use of flight spoiler and maximum diminishing of the are of engine and landing gear nacelles.

During the choice of structurally-power schemes, hinge-fitting schemes and kinematics of the high-lift devices we need to come from the statistics and experience of domestic and foreign aircraft construction. We need to mention that in the majority of



existing constructions elements of high-lift devices are done by longeron structurally-power schemes. In my airplane the rate of the relative chords of wing high-lift devices is:

$$bf = 0.3..0.4 - \text{for three slotted flaps and Fowler's flaps;}$$

### 2.1.2 Fuselage layout

During the choice of the shape and the size of fuselage cross section we need to come from the aerodynamic demands (streamlining and cross section).

Applicable to the subsonic passenger and cargo aircrafts ( $V < 800$  km/h) wave resistance doesn't affect it. So we need to choose from the conditions of the list values friction resistance  $C_{xf}$  and profile resistance  $C_{xp}$ .

During the transonic and subsonic flights, shape of fuselage nose part affects the value of wave resistance  $C_{xw}$ . Application of circular shape of fuselage nose part significantly diminishing its wave resistance.

For transonic airplanes fuselage nose part has to be:

$$l_{npf} = 2 \times D_f = 2 \times 5 = 10 \text{ m}$$

Except aerodynamic requirements consideration during the choice of cross section shape, we need to consider the strength and layout requirements.

For ensuring of the minimal weight, the most convenient fuselage cross section shape is circular cross section. In this case we have the minimal fuselage skin width. As the partial case we may use the combination of two or more vertical or horizontal series of circles. For cargo aircrafts the aerodynamics is not so important in the fuselage shape choice, and the cross section shape is may be close to rectangular one.

To geometrical parameters we concern: fuselage diameter  $D_f$ ; fuselage length  $l_f$ ; fuselage aspect ratio  $\lambda_f$ ; fuselage nose part aspect ratio  $\lambda_{np}$ ; tail unit aspect ratio  $\lambda_{TU}$ . Fuselage length is determined considering the aircraft scheme, layout and airplane center-of-gravity position peculiarities, and the conditions of landing angle of attack  $\alpha_{land}$  ensuring.

To geometrical parameters we concern: fuselage diameter  $D_f$ ; fuselage length  $l_f$ ; fuselage

aspect ratio  $\lambda_f$ ; fuselage nose part aspect ratio  $\lambda_{np}$ ; tail unit aspect ratio  $\lambda_{TU}$ .

Fuselage length is equal:

$$l_f = \lambda_f \times D_f = 9.8 \times 5 = 49 [m]$$

Fuselage nose part aspect ratio is equal:

$$\lambda_{fnp} = \frac{l_{fnp}}{D_f} = \frac{10}{5} = 2$$

Sum of nose part and rear part aspect ratio:

$$\lambda_{fnp} + \lambda_{frrp} = 5$$

So, aspect ratio of rear part is equal:

$$\lambda_{frrp} = 5 - \lambda_{fnp} = 3$$

Length of the fuselage rear part is equal:

$$l_{frrp} = \lambda_{frrp} \times D_f = 3 \times 5 = 15$$

During the determination of fuselage length, we seek for approaching minimum mid-section  $S_{ms}$  from one side and layout demands from the other.

For passenger and cargo airplanes fuselage mid-section first of all comes from the size of passenger saloon or cargo cabin. One of the main parameter, determining the mid-section of passenger airplane is the height of the passenger saloon.

For short range airplanes we may take the height as:  $h_1=1.75m$ ; passage width  $b_p=0.45...0.5m$ ; the distance from the window to the floor  $h_2=1m$ ; luggage space  $h_3=0.6...0.9m$ .

For long range airplanes correspondingly: the height as:  $h_1=1.9m$ ; passage width  $b_p=0.6m$ ; the distance from the window to the floor  $h_2=1m$ ; luggage space  $h_3=0.9...1.3m$ .

$$H_{cab} = 1,48 + 0,17B_{cab} = 1,48 + 0,17 \times 3,55 = 2,0835 [m]$$

I choose the next parameters:

Cabin height is equal:  $H_{cab} = 2.1 \text{ m}$ .

From the design point of view, it is convenient to have round cross section, because in this case it'll be the strongest and the lightest. But for passenger and cargo placing this shape is not always the most convenient one.

In the most cases, one of the most suitable ways is to use the combination of two circles intersection, or oval shape of the fuselage. We need to remember that the oval shape is not suitable in the production, because the upper and lower panels will bend due to extra pressure and will demand extra bilge beams, and other construction amplifications.

Step of normal bulkhead in the fuselage construction is in the range of 360...500mm, depends on the fuselage type and class of passenger saloon.

The windows are placed in one light row. The shape of the window is round, with the diameter of 300...400mm, or rectangular with the rounded corners. The window step corresponds to bulkhead step and is 500...510mm.

For economic salon with the scheme of allocation of seats in the one row (2/2/2) determine the appropriate width of the cabin:

$$B_{cab} = n_2 b_2 + n_3 b_3 + n_n b_n + 2 + \delta + 2\delta = 4.98 \text{ [m]}$$

The lengths of the cabin is equal:

$$L_{cab} = L_1 + (N - 1) + L_{cr} + L_2 = 28.2 \text{ [m]}$$

### 2.1.3 Luggage compartment

Given the fact that the unit of load on floor  $K = 400... 600 \text{ kg/m}^2$

The area of cargo compartment is defined:

$$S_{cargo} = \frac{M_{bag}}{0,4K} + \frac{M_{cargo \text{ and } mail}}{0,6K} = \frac{20 \times 182}{0,4 \times 500} + \frac{15 \times 182}{0,6 \times 500} = 27.3 \text{ [m}^2\text{]}$$

Cargo compartment volume is equal:

$$V_{cargo} = v \times n_{pass} = 0,12 \times 182 = 21.84[m^3]$$

Luggage compartment design similar to the prototype.

#### **2.1.4 Galleys and buffets**

International standards provide that if the plane made a mixed layout, be sure to make two dishes. If flight duration less than 3 hours at this time of food to passengers not issued in this case provided cupboards for water and tea. Tickets to the flight time less than one hour buffets and toilets can not be done. Kitchen cupboards and must be placed at the door, preferably between the cockpit and passenger or cargo have separate doors. Refreshment and food can not be placed near the toilet facilities or connect with wardrobe.

Volume of buffets (galleys) is equal:

$$V_{galley} = 01 \times 182 = 21 [m^3]$$

Area of buffets (galley) is equal:

$$S_{galley} = \frac{V_{galley}}{H_{cab}} = \frac{21.84}{2.1} = 10 [m^3]$$

Number of meals per passenger breakfast, lunch and dinner – 0,8 kg; tea and water – 0,4 kg; If food organized once it is given a set number 1 weighing 0,62 kg. Food passengers appears every 3.5...4 hour flight.

Buffet design similar to prototype.

#### **2.1.5 Lavatories**

Number of toilet facilities is determined by the number of passengers and flight duration: with  $t > 4:00$  one toilet for 40 passengers, at  $t = 2 \dots 4$  hours and 50 passenger's  $t < 2$  hours to 60 passengers.

The number of lavatories I choose according to the original airplane and it is equal:

$$n_{lav}=5$$

Area of lavatory:

$$S_{lav} = 1,5[m^3]$$

Width of lavatory: 1m. Toilets design similar to the prototype.

### 2.1.6 Layout and calculation of basic parameters of tail unit

One of the most important tasks of the aerodynamic layout is the choice of tail unit placing. For ensuring longitudinal stability during overloading its center of gravity should be placed in front of the aircraft focus and the distance between these points, related to the mean value of wing aerodynamic chord, determines the rate of longitudinal stability.

$$m_x^{Cy} = \bar{x}_T - \bar{x}_F < 0$$

Where  $m_x^{Cy}$  –is the moment coefficient;  $x_T, x_F$ - center of gravity and focus coordinates. If  $m_x^{Cy}=0$ , than the plane has the neutral longitudinal static stability, if  $m_x^{Cy}>0$ , than the plane is statically instable. In the normal aircraft scheme (tail unit is behind the wing), focus of the combination wing – fuselage during the install of the tail unit of moved back.

Static range of static moment coefficient: horizontal  $A_{htu}$ , vertical  $A_{vtu}$  given in the table with typical arm  $H_{tu}$  and  $V_{tu}$  correlations. Using table, we may find the first approach of geometrical parameters determination.

Determination of the tail unit geometrical parameters

Area of vertical tail unit is equal:

$$S_{VTU} = (0,18 \dots 0,25)S_w = 20 [m^2]$$

$$A_{htu} = 0.725$$

$$A_{vtu} = 0.1$$

$$L_{htu} \approx L_{vtu} = 3$$

$$L_{htu} = 20.7 \text{ m}$$

$$S_{vtu} = 0.1 \cdot 47.5 \cdot 286/20.7 = 65.6 \text{ ( m}^2 \text{ )}$$

where  $L_{VTU}$  – length of vertical tail unit.

For mid- range passenger, turbo jet engine:

Area o horizontal tail unit is equal:

$$S_{HTU} = (0,12 \dots 0,2)S_w = \frac{286}{20.7} = 13.8 \text{ [m}^2\text{]}$$

Values  $L_{htu}$  and  $L_{vtu}$  depend on some factors. First of all, their value are influenced by: the length of he nose part and tail part of the fuselage, sweptback and wing location, and also from the conditions of stability and control of the airplane.

Determination of the elevator area and direction:

Altitude elevator area:

$$S_{el} = (0,3 \dots 0,4)S_{HTU} = 0,35 \times 13.8 = 4,9 \text{ [m}^2\text{]}$$

Rudder area:

$$S_{rud} = (0,35 \dots 0,45)S_{VTU} = 0,4 \times 65 = 26 \text{ [m}^2\text{]}$$

I choose the area of aerodynamic balance.

If,  $M \geq 0,75$  , so  $S_{el} \approx S_{rud} = (0,18 \dots 0,23) S$

Elevator balance area is equal:

$$S_{el} = S_{EL} \cdot 0,2 = 0,2 \cdot 65 = 13 \text{ [m}^2\text{]}$$

Rudder balance area is equal:

$$S_{rud} = S_{RUD} \cdot 0,2 = 0,2 \cdot 4,935 = 0,987 [m^2]$$

The area of altitude elevator trim tab:

$$S_{te} = S_{EL} \cdot 0,1 = 0,1 \cdot 4,935 = 0,4935 [m^2]$$

Area of rudder trim tab is equal:

$$S_{tr} = S_{RUD} \cdot 0,05 = 0,05 \cdot 65 = 3.25 [m^2]$$

Root chord of horizontal stabilizer is:

$$l_{HTU} = (0,32 \dots 0,5) l_w = 19.5 \text{ m}$$

### **2.1.7 Landing gear design**

In the primary stage of design, when the airplane center-of-gravity position is defined and there is no drawing of airplane general view, only the part of landing gear parameters may be determined.

Main wheel axel offset is:

$$e = b_{MAC} \cdot (0.15 \dots 0,2) = 0.2 \cdot 6.9 = 1.38 [m]$$

With the large wheel axial offset the lift-off of the front gear during take-off is complicated, and with small, the drop of the airplane on the tail is possible, when the loading of the back of the airplane comes first. Landing gear wheel base comes from the expression:

Landing gear wheel base comes from the expression:

(2.44)

$$B = (0,3 \dots 0,4)L_{\phi} = (6 \dots 10)e$$

(2.45)

$$B = (0,3 \dots 0,4)L_f = (6 \dots 10)e = 0,4 \times 49 = 19.6 [m]$$

The last equation means that the nose support carries 6...10% of aircraft weight.

Front wheel axial offset will be equal:

$$d_{ng} = B - e = 18.22 [m]$$

Wheel track is:

(2.47)

$$T = (0,7 \dots 1,2)B \leq 12 = 0.7 \cdot 13.8 = 9.3$$

I choose this parameter similar to prototype:

On a condition of the prevention of the side nose-over the value  $K$  should be  $> 2H$ , where  $H$  – is the distance from runway to the center of gravity.

Wheels for the landing gear is chosen by the size and run loading on it from the take off weight; for the front support we consider dynamic loading also.

$$WT \geq 2 \cdot H_{cg}$$

s:  $9.3m > 8m$ , the condition is satisfied

Type of the pneumatics (balloon, half balloon, arched) and the pressure in it is determined by the runway surface, which should be used. We install breaks on the main wheel, and sometimes for the front wheel also.

The load on the wheel is determined:

$$K_g = 1.5 \dots 2.0 - \text{dynamics coefficient.}$$



Nose wheel load is equal:

$$P_{NLG} = \frac{(9,81 \cdot e \cdot k_g \cdot m_0)}{(B \cdot z)} = \frac{(9,81 \cdot 1.38 \cdot 1,5 \cdot 130837)}{(19.6 \cdot 2)} = \frac{2656867}{39.2}$$

$$P_{NLG} = 67777 [N]$$

Main wheel load is equal:

$$P_{MLG} = \frac{(9,81 \times (B - e) \times m_0)}{(B \times z \times n)} = \frac{(9,81 \times (19.6 - 1.38) \cdot 130837)}{(19.6 \cdot 4 \cdot 2)}$$

$$= \frac{2338556}{156.8} = 149142 [N]$$

Table 2.1 – Aviation tires for designing aircraft

Main gear		Nose gear	
Tire size	Ply rating	Tire size	Ply rating
H46x81.0-20	32	23x7.0-12 mm	12

### 2.1.8 Choice and description of power plant

The D-18T series 3 is used to power the passenger and cargo aircrafts. The engine is equipped with an efficient thrust reverser mounted in fan duct. The engine's module design together with efficient component condition diagnostics means provides possibility of on condition operation without plant overhauls.

high takeoff thrust;

- low specific fuel consumption;
- low noise and pollutant emission levels (comply with ICAO standards);
- high maintainability and repairability.

Table 2.2- Example of application D18-T turbofan engine

Model	Thrust	Bypass ratio	Dry weight
D-18T3	47,68	5.7	4.100kg

## 2.2 Determination of centering of the equipped wing

Mass of the equipped wing contains the mass of its structure, mass of the equipment placed in the wing and mass of the fuel. Regardless of the place of mounting (to the wing or to the fuselage), the main landing gear and the front gear are included in the mass register of the equipped wing. The mass register includes names of the objects, mass themselves and their center of gravity coordinates. The origin of the given coordinates of the mass centers is chosen by the projection of the nose point of the mean aerodynamic chord (MAC) for the surface XOY. The positive meanings of the coordinates of the mass centers are accepted for the end part of the aircraft.

The example list of the mass objects for the aircraft, where the engines are located under the wing, included the names given in the table 2.3.

The example list of the mass objects for the aircraft, where the engines are located in the wing, included the names given in the table 2.3. The mass of AC is 91295 kg.

Coordinates of the center of power for the equipped wing are defined by the formulas:

Table 2.3 - Trim sheet of equipped wing masses

	Object	mrel	m <sub>i</sub>	X <sub>i</sub>	m <sub>i</sub> * X <sub>i</sub>
1	wing structure	0,10022	13112,48	2,962	38842,72
2	fuel system	0,0087	1138,28	2,962	3371,89
3	airplane control, 30%	0,00159	208,03	4,133	859,87
4	electrical equipment, 30%	0,00903	1181,46	0,689	813,91

5	anti-ice system, 70%	0,01095	1432,67	0,689	986,96
6	hydraulic systems, 70%	0,01071	1401,26	4,133	5791,99
7	power plant	0,09825	12854,74	-2,21	-28408,96
8	eq. wing without	0,23945	31328,92	0,710	22258,38
9	nose landing gear	0,0027645	361,69	-16,844	-6092,60
10	Main landing gear	0,0156655	2049,63	2,756	5647,95
11	fuel	0,28859	37758,25	2,962	111850,13
12	total	0,54647	71498,49	1,869	133663,86

### 2.2.2 Determination of the centering of the equipped fuselage:

Origin of the coordinates is chosen in the projection of the nose of the fuselage on the horizontal axis. For the axis X the construction part of the fuselage is given. The example list of the objects for the AC, which engines are mounted under the wing, is given in table 2.4.

The CG coordinates of the FEF are determined by formulas:

$$X_f = \frac{\sum m_i X_i}{\sum m_i}; Y_f = \frac{\sum m_i Y_i}{\sum m_i}$$

We can find fuselage center of gravity coordinate  $X_f$  by divided sum of mass moment of the fuselage ( $m_i X_i$ ) on sum of total mass of fuselage ( $\sum m_i$ ):

$$X_f = \sum m_i \times X_i / \sum m_i = 23,553$$

AC fuselage centering of gravity masses drawing which is presented in (Appendix C):

After we determined the center of gravity (CG of FEW) and fuselage, we construct the moment equilibrium equation relatively fuselage nose:

$$m_f \times x_f + m_w \times (x_{MAC} + x'_w) = m_0 \times (x_{MAC} + C)$$

From here we determined the wing MAC leading edge position relative to fuselage, means  $X_{MAC}$  value by formula:

$$X_{MAC} = \frac{m_f \times x_f + m_w x_w - m_0 \times c_n}{m_0 - m_w} = 22,502$$

Where  $m_0$  – AC takeoff mass, kg;  $m_f$  – mass of FEF, kg;  $m_w$  – mass of FEW, kg;  $C$  – distance from MAC leading edge to the CG point, determined by the designer.

Table 2.4 – Trim sheet of equipped fuselage masses

No	Object	mrel	m_i	X_i	m_i * X_i
1	fuselage	0,12681	16591,44	22	365011,68
2	horizontal tail	0,0103	1347,62	44	59295,33
3	vertical tail	0,01001	1309,68	33	43219,39
4	radar	0,0028	366,34	0,5	183,17
5	radio equipment	0,0021	274,76	1	274,76
6	instrument panel	0,0049	641,10	2,5	1602,75
7	aero navigation equipment	0,0042	549,52	2	1099,03
8	lavatory1	0,00076431	100	4	400
9	lavatory 2,3	0,00152862	200	19	3800

10	lavatory 4,5	0,00152862	200	34	6800
11	galley 1	0,00496801	650	4,5	2925
12	galley 2	0,00206364	270	19	5130

Continuation of table 2.4

13	galley 3	0,00573232	750	38	28500
14	aircraft control system 70%	0,00371	485,41	25	12135,13
15	hydro-pneumatic sys 30%	0,00459	600,54	25	15013,55
16	electrical equipment 70%	0,02107	2756,74	25	68918,39
17	Not typical equipment	0,0093	1216,78	25	30419,60
18	Sound insulation	0,0094	1229,87	25	30746,69
19	Anice&airconditon	0,00219	286,53	25	7163,33
20	passenger seats (business)	0,00058088	76	7,15	543,4
21	passenger seats (economic class)	0,00997424	1305	20,5	26752,5

22	seats of flight attendants	0,00275152	360	25	9000
23	seats of pilot	0,00229293	300	2,5	750
24	addition equip.,	0,001965	257,09	18	4627,70
25	Equil.,fuel without payload	0,24553009	32124,42	22,55	724311,40
26	Passenger business	0,00428013	560	8,3	4648
27	On board meal	0,00377	493,26	24,5	12084,76

28	baggage	0,0534864	6998	24,5	171451
29	Cargo mail	0,05044445	6600	5,5	3630
30	crew	0,00504444	660	5,5	3630
31	Passenger economy.,	0,09095287	119000	20,2	240380
32	total	0,45350837	59335,68	22,21606	1318205,16
33	total fraction	0,99997837			

### 2.2.3 Calculation of center of gravity positioning variants

The list of mass objects for center of gravity variant calculation given in Table 2.5 and Center of gravity calculation options given in table 2.6, completes on the base of both previous tables. Origin of the coordinates is chosen in the projection of the nose of the fuselage on the horizontal axis. After designing of the wing and the fuselage we have made the calculations of the center of gravity determination of the equipped aircraft.

Table 2.5 – Calculation of C.G. positioning variants

Object	$m_i$	$X_{i,, M}$	Kg.m
equipped wing (without fuel and landing gear)	31328,92	22,1401	693625,3
Nose landing gear (extended)	361,69	4,5852	1658,47
main landing gear (extended)	2049,63	24,1852	49570,69
fuel/fuel reserve	37758,25	24,3919	920995,2
equipped fuselage (without payload)	32124,42	22,5471	724311,4
passengers of business class	560	8,3	4648
passengers of economy class	11900	20,2	240380

baggage	998	5	74950
cargo	0	25	165000
crew	660	5,5	3630
nose landing gear (retracted)	361,69	3,5852	1296,771
main landing gear (retracted)	2049,63	24,1852	49570,69
reserve fuel	4448,46	25	111211,5

Table 2.6 – Airplanes C.G. position variants

O	Object	$m_i$	$X_{i,, M}$	$X_m, M$	% MAC
---	--------	-------	-------------	----------	-------

1	take off mass (L.G. extended)	130340,915	2978769,09	22,8537	20,67
2	take off mass (L.G. retracted)	130340,915	2978407,39	22,8509	20,63
3	landing weight (LG extended)	9703,1233	216898,34	22,3535	13,41
4	ferry version	104282,915	2393429,39	22,9513	22,089
5	parking version	65864,6653	1469165,89	22,3058	12,719

## Conclusion to part 2

In this section of the work conclusion was made base on the determination of the center mass position sand its characteristics. Estimated and showed the main calculations of the aircraft. We have also checked the mass position of the main parts of the aircraft and main equipment and furnishing by its distance from the main aerodynamic chord. After designing of the wing and the fuselage we have made the calculations of the center of gravity determination of the equipped aircraft of the main equipment and furnishing the distance from the main aerodynamic chord. Which range from 13.41-20.67 i.e. for both take off mass and landing weight



**PART 3**  
**CONCEPTUAL DESIGN OF A SMART STORAGE BIN**

**3.1 Analysis of storage bin operation**

A system for displaying storage capacity status information for one or more passenger storage bins in an aircraft, comprising: at least one first sensor coupled to each of the passenger storage bins for providing a first output signal proportional to a first type of capacity level of the associated passenger storage bin; a processor for each of the passenger storage bins coupled to the associated at least one first sensor and configured to calculate, based upon the output signal from the at least one first sensor, whether or not the associated storage bin is filled to capacity, the processor also configured to provide an output signal indicating whether or not the associated storage bin is filled to capacity; and a display device for each passenger storage bin coupled to receive the output signal from the associated processor and for providing a visual indication whether or not the associated storage bin is filled to capacity.

In another word Strain gauges are sensors which are used in variety of physical measurements. They change resistance when they are stretched or compressed. Because of this property, strain gauges often are bonded to a solid surface and used for measuring acceleration, pressure, tension and force. We can use the measurement of tension to determine the weight applied to the load cell. Fundamentally, strain is a change in length per unit length. For instance, if a 1 m long beam is stretched to 1.000002 m, the strain is 2 micro strains. One characteristic of strain gauges are gauge factor, and is defined as fractional change in resistance divided by the strain. For example, if we have strain gauge with gauge factor of 2, for the previous example the resistance change would be  $(2*2)*10^{-6} = 4*10^{-6} \Rightarrow 4\mu\Omega$ . Normally strain gauge resistance value are around 120 – 350  $\Omega$ , however there are some gauges with resistance as low as 30 $\Omega$  or as high as 3k $\Omega$  If a strip of conductive metal is stretched, it will become skinnier and longer, which will result an increasing electrical resistance. On the contrary, if you compress the strain gauge, it will broaden and shorten, hence the electrical resistance will decrease. If these stretches don't exceed strain gauge's elasticity, the strip can be used for measuring weight. A typical strain gauge would look something like this:

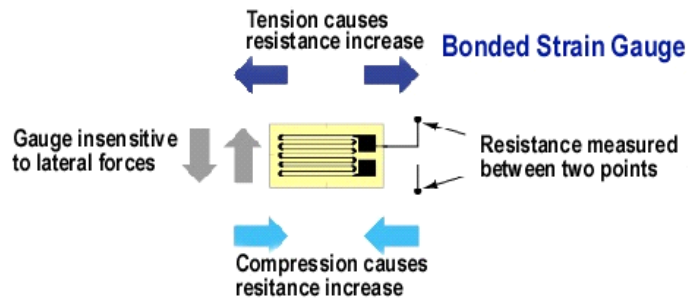

Figure 3.1 - Strain gauge

In one aspect, a system is provided for displaying storage capacity status information for one or more passenger storage bins in an aircraft. The system includes at least one first sensor coupled to each of the passenger storage bins for providing a first output signal proportional to a first type of capacity level of the associated passenger storage bin. The system also includes a processor for each of the passenger storage bins coupled to the associated at least one first sensor and configured to calculate, based upon the output signal from the at least one first sensor, whether or not the associated storage bin is filled to capacity. The processor is also configured to provide an output signal indicating whether or not the associated storage bin is filled to capacity. Finally, the system includes a display device for each passenger storage bin coupled to receive the output signal from the associated processor and for providing a visual indication whether or not the associated storage bin is filled to capacity.

In one further aspect, each of the at least one first sensors may be a load sensor and the output signal from each of the at least one first sensors may be proportional to a weight of items within the associated passenger storage bin.

In another further aspect, each of the at least one first sensors may be a range sensor and the output signal from each of the at least one first sensors may be proportional to an amount of empty space available within the associated passenger storage bin.

In yet another further aspect, the system may also include at least one second sensor coupled to each of the passenger storage bins for providing an output signal proportional to a second type of capacity level of the associated passenger storage bin. The processor may

also be coupled to the associated at least one second sensor and may be further configured to calculate whether or not the associated storage bin is filled to capacity based on the output signals from the at least one first sensor and the at least one second sensor. Each of the at least one first sensors may be a load sensor and the output signal from each of the at least one first sensors may be proportional to a weight of items within the associated passenger storage bin. Each of the at least one second sensors may be a range sensor and the output signal from each of the at least one second sensors may be proportional to an amount of empty space available within the associated passenger storage bin.

Each processor may be configured to calculate whether or not the associated storage bin is filled to capacity based, at least in part, on a predetermined weight level. In addition, each processor may be configured to calculate whether or not the associated storage bin is filled to capacity based, at least in part, on a predetermined amount of empty space.

The system may also include an attendant console coupled to each of the processors for the one or more passenger storage bins for receiving and displaying the storage capacity status of each of the one or more passenger storage bins. Also, each of the processors for the one or more passenger storage bins may be coupled to each other via a network and the system may also include a wireless interface coupled to the network and a handheld wireless device coupled to the wireless interface for receiving, via the wireless interface, and displaying the storage capacity status of each of the one or more passenger storage bins.

Each of the display devices may be a light emitting element or a display panel located on an external portion of or adjacent to the associated passenger storage bin. Each of the at least one load sensors may be coupled to a support structure of the associated passenger storage bin to measure load of the associated storage bin or may be mounted on a bottom panel of the associated passenger storage bin to measure load of the associated storage bin.

In another aspect, a system is provided for displaying storage capacity status information for one or more passenger storage bins in an aircraft. The system includes at least one first sensor coupled to each of the passenger storage bins for providing a first output signal proportional to a first type of capacity level of the associated passenger storage bin.

The system also includes a processor coupled to each of the at least one first sensors and configured to calculate, for each of the at least one first sensors and based upon the output signal from the at least one first sensor, whether or not the storage bin associated with the at least one first sensor is filled to capacity. The processor is also configured to provide an output signal for each of the at least one first sensors indicating whether or not the storage bin associated with the at least one first sensor is filled to capacity. Finally, the system includes a display device for each passenger storage bin coupled to receive the output signal from the processor and for providing a visual indication whether or not the associated passenger storage bin is filled to capacity.

In one further aspect, each of the at least one first sensors may be a load sensor and the first output signal from each of the at least one first sensors may be proportional to a weight of items within the associated passenger storage bin.

In another further aspect, each of the at least one first sensors may be a range sensor and the first output signal from each of the at least one first sensors may be proportional to an amount of empty space available within the associated passenger storage bin.

In yet another further aspect, the system may also include at least one second sensor coupled to each of the passenger storage bins for providing an output signal proportional to a second type of capacity level of the associated passenger storage bin. The processor may also be coupled to each of the at least one second sensors and may be further configured to calculate whether or not the storage bin associated with each of the at least one second sensors is filled to capacity based on the output signals from the at least one first sensor and the at least one second sensor. Each of the at least one first sensors may be a load sensor and the output signal from each of the at least one first sensors may be proportional to a weight of items within the associated passenger storage bin. Each of the at least one second sensors may be a range sensor and the output signal from each of the at least one second sensors may be proportional to an amount of empty space available within the associated passenger storage bin.

An attendant console may be coupled to the processor for receiving and displaying the storage capacity status of each of the one or more passenger storage bins.

In yet another aspect, a method for displaying storage capacity status information for one or more passenger storage bins in an aircraft. First, for each of the passenger storage bins, a weight of items within the associated passenger storage bin is determined. Next, for each of the passenger storage bins, an amount of empty space available within the associated passenger storage bin is determined. Then, based upon the weight of items within the associated passenger storage bin and the amount of empty space available within the associated passenger storage bin, a processor calculates whether or not the associated storage bin is filled to capacity. Finally, based upon the calculation by the processor, a visual indication is provided indicating whether or not the associated storage bin is filled to capacity.

The features, functions, and advantages that have been discussed can be achieved independently in various embodiments or may be combined in yet other embodiments, further details of which can be seen with reference to the following description and drawings.

### **3.2 Detailed description of storage bin design**

On this section I'm going to describe in detailed the drawing with a reference numbers which refer elements throughout the drawings, which illustrate various exemplary embodiments of the present in it.

The system disclosed herein helps to speed the boarding process by providing a clear visual indication of whether there is available space in each overhead luggage storage bin. Preferably, such indication is visible from a distance even if the overhead luggage storage bin is closed. With this system, passengers may proceed down an aircraft aisle quickly to an available bin, without having to open each closed bin to check for available space. The block diagram is shown for an overhead luggage storage bin capacity sensing.

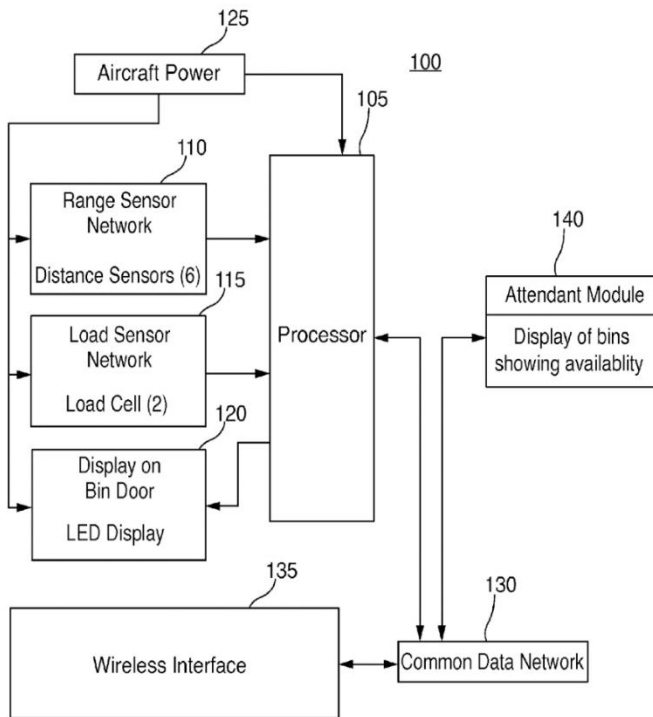

Figure 3.1 - Block circuit diagram of an overhead luggage storage bin capacity sensing system according to a first embodiment of the present disclosure

On the figure.3.2 is a diagram showing load sensors positioned on a bottom surface of an overhead luggage storage bin according to the present disclosure.

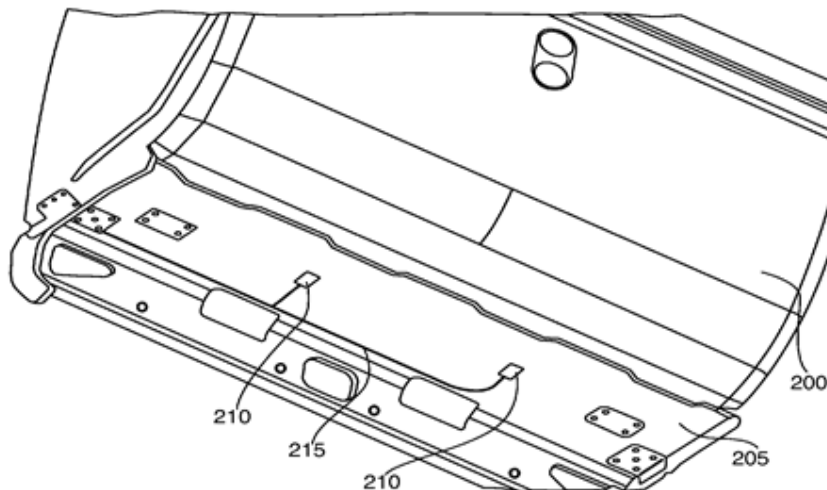

Figure 3.2. diagram showing load sensors positioned on a bottom surface

On the figure.3.3 is a diagram showing range sensors positioned on a top surface of an overhead luggage storage bin according to the present disclosure;

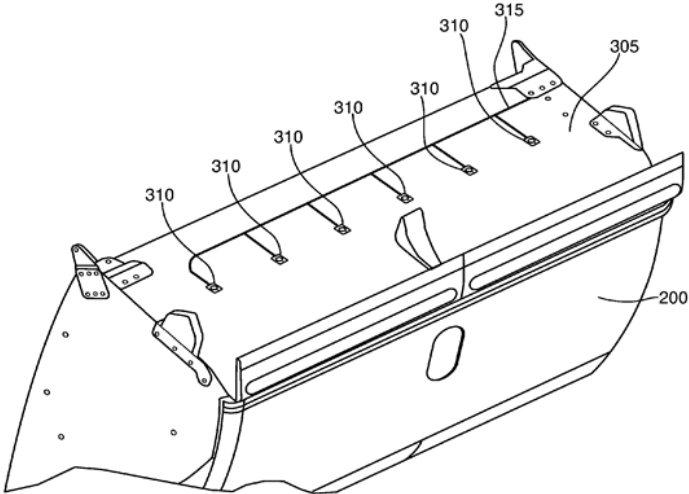
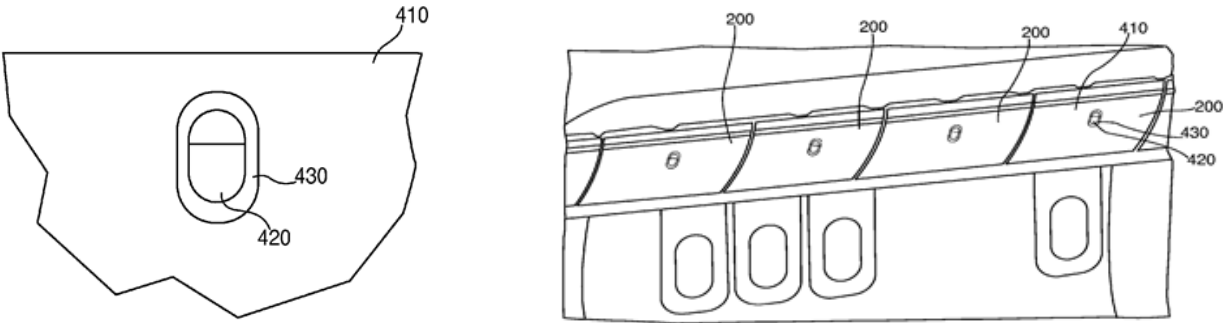

Figure 3.3 - Diagram showing range sensors

On the figure.3.4A is a diagram showing visual indicators according to the present disclosure positioned on a front surface of overhead luggage storage bins, and figure. 4b is a diagram showing a close-up of a single visual indicator from FIG. 4a;



a)

b)



Figure 3.3 (a) overhead luggage storage. (b) a diagram showing a close-up of a single visual indicator

On the figure.3.5 is block circuit diagram of an overhead luggage storage bin capacity sensing system according to a second embodiment of the present disclosure

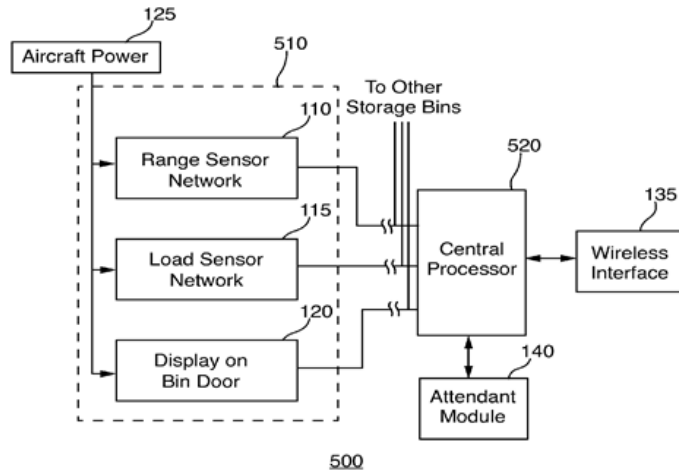

Figure 3.5. block circuit diagram of an overhead luggage storage bin

On the figure.3.6 is a flowchart of a method of determining overhead luggage storage bin capacity according to the present disclosure.

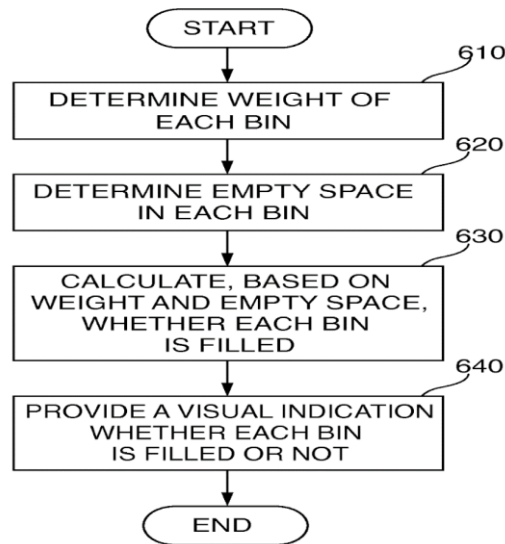

Figure 3.6. flowchart of a method of determining overhead luggage storage bin capacity.

The following detailed description, given by way of example and not intended to limit the present disclosure solely thereto, will best be understood in conjunction with the accompanying drawings in which:

- 105- Processor
- 100-System
- 110-Range Sensor
- 115-Load Sensor
- 120-Data network
- 130-Common Data network
- 135-Wireless Interface
- 140-Display Console
- 200-Storage bins
- 201-load sensor
- 210-load sensor
- 215-wiring
- 310-ultrarangefinder devices
- 305-top panel
- 315-wiring
- 410-front panel
- 420-latch mechanism
- 430-display device
- 500-Sensing system
- 510-one storage bin

520-Central processor

600-flow chart

(610-640)-Step.

### **3.3 Smart storage bin system analysis of operation**

In the present disclosure, like reference numbers refer to like elements throughout the drawings, which illustrate various exemplary embodiments of the present disclosure.

The system disclosed herein helps to speed the boarding process by providing a clear visual indication of whether there is available space in each overhead luggage storage bin. Preferably, such indication is visible from a distance even if the overhead luggage storage bin is closed. With this system, passengers may proceed down an aircraft aisle quickly to an available bin, without having to open each closed bin to check for available space. The system disclosed herein allows passengers to easily identify and fill overhead luggage storage bins only partially filled but closed by other passengers. The present system eases the frustrating and time-consuming search for overhead space that occurs when other passengers close partially filled overhead luggage storage bins, and thus speeds the boarding process and provides a smoother and less stressful boarding experience for both flight attendants and passengers. In addition, when passengers spend less time searching for storage space and instead are able to move directly to an empty bin, there is less interference (and resultant passenger stress) in the aisles. A quicker boarding process is also instrumental in improving an airline's on-time performance.

System according to a first embodiment. Sensing system includes, for each overhead luggage storage bin, a block diagram is shown for an overhead luggage storage bin capacity sensing, a processor having a first input coupled to a range sensor network and a second input coupled to a load sensor network. In addition, processor may have an output coupled to a display device which is preferably mounted on an external portion of a door of the overhead luggage storage bin. As one of ordinary skill in the art will readily recognize,

display device may be mounted in other positions adjacent to the associated overhead luggage storage bin and still provide adequate status notice to passengers. Processor, range sensor network, load sensor network and display device are all powered via the aircraft power system, which in one embodiment provides power at 12-volt DC. In addition, processor and the sensors selected for use in range sensor network and load sensor network are preferably selected to be low power, low voltage units to minimize the loading on aircraft power system. Display device is preferably an LED device which provides a clear indication that the associated overhead luggage storage bin is either “full” or “not full.” For example, display device may emit a first color (e.g., green) when the associated overhead luggage storage bin is not filled and a second color (e.g., red) when the overhead luggage storage bin is filled. In one alternative embodiment, display device may only become active (lit) when the associated overhead luggage storage bin is filled (or when it is not filled)—e.g., an LED device positioned behind a translucent “FULL” (or “NOT FULL”) panel. In another alternative embodiment, display device may be an LED display which provides more detailed description of the status of the associated overhead luggage storage bin, e.g., a display which states one of “FULL” or “NOT FULL.”

The processor for each overhead luggage storage bin may be coupled to a wireless interface (discussed below) and/or one or more display consoles via a common data network. The display console displays the status of each overhead luggage storage bin on the aircraft. Display console may be provided for access only by the flight attendants, or may be publicly located at the entrance of the aircraft so that entering passengers can immediately access the status of each overhead luggage storage bin. In a further embodiment, more than one display consoles may be provided, e.g., one for use by flight attendants and the other for use by entering passengers. Data network may be, for example, an aircraft data network compliant with industry standard ARINC-664 network protocol. Since aircraft data network drops are already available in new aircraft for passenger services units and oxygen boxes, the additional wiring necessary to interface each processor to the aircraft data network is minimal. In another embodiment, groups of processors may be daisy-chained together, with

each processor linked to processors in adjacent overhead luggage storage bins. In this embodiment, only one processor among the group of processors is linked to the aircraft data network. This allows for a reduced number of interfaces to the aircraft data network, a reduced complexity, and a streamlined design and easier installation. This also decreases the overall system weight and cost of additional wiring by keeping the system self-contained.

As described above, in the present system each overhead luggage storage bin includes a range sensor network and a load sensor network, each network, coupled to an input of a processor, preferably an on-board microcontroller. Processor is configured to receive signals from each range sensor within range sensor network and signals from each load sensor in load sensor network and, based on such signals, to determine if the associated overhead luggage storage bin has mass or volume capacity available (i.e., if it is filled, either by weight or volume). Based on such determination, processor is configured to output a signal to display device that indicates current status information, i.e., at least whether the particular overhead luggage storage bin is either "FULL" or "NOT FULL," as discussed above. Processor is also configured to communicate that status information to a display console via the aircraft data network. In a further embodiment, a wireless interface (e.g., a Bluetooth® interface) may be provided coupled to the aircraft data network for transmitting signals to a flight attendant's wireless device (e.g., a smart phone with a Bluetooth® interface and associated specialized application) to allow each flight attendant to access status information throughout the aircraft. In other embodiments, satisfactory operation may be obtained by using only a range sensor network or only a load sensor network to determine if full capacity of each respective overhead luggage storage bin has been reached. Each load sensor in the load sensor network is preferably mounted on a bottom panel of the overhead luggage storage bin. Each load sensor is preferably a conventional load cell (or equivalent as known to one of ordinary skill in the art). Each load sensor is coupled to processor via wiring. In alternative embodiments, load sensors may be mounted either on support rods or attachment fittings for overhead luggage storage bin (instead of on bottom panel). Each load sensor provides an output signal which enable processor to determine, based upon

predetermined settings, if a maximum weight for overhead luggage storage bin has been met by the luggage or other items currently stored in that bin (meaning that nothing further should be placed into (overhead luggage storage bin). Two load sensors are shown for the load sensor network, but, in an alternative embodiment, additional load sensors may be included, and satisfactory results may be obtained in some cases with only one load sensor.

range sensor network preferably consists of six ultrasonic rangefinder devices mounted on a top panel of overhead luggage storage bin that are used in system to determine available volume (space) within overhead luggage storage bin. Each of the ultrasonic rangefinder devices provides a volume signal to processor via wiring to allow processor to generate a map of the current volume of stowed luggage within overhead luggage storage bin to determine, based on predetermined settings, whether there is any space remaining within overhead luggage storage bin.

Six ultrasonic rangefinder devices are shown in range sensor network. As one of ordinary skill in the art will readily recognize, the precise number of such devices required in range sensor network depends upon the size of overhead luggage storage bin and the type of such device selected for use in system. each overhead luggage storage bin has a front panel with a latch mechanism. A display device may be provided surrounding latch mechanism which is, in the preferred embodiment, capable of being activated in two different colors, e.g., red and green. In operation, processor is configured to determine, preferably based on both the received load data and the received volume data, whether or not the associated overhead luggage storage bin has space available for additional luggage, and provides a status indication (i.e., causes display device to be activated as a red light when overhead luggage storage bin is filled and to be activated as a green light when overhead luggage storage bin is not filled). As discussed above and as one of ordinary skill in the art will readily recognize, there are many ways to display status and all are intended to fall within the scope of the present disclosure. In a further embodiment, as discussed

above, status information for each overhead luggage storage bin may also be transmitted to display console.

a block diagram is shown for an overhead luggage storage bin capacity sensing system according to a second embodiment. Sensing system includes, for each overhead luggage storage bin (one storage bin is represented by dotted line), a range sensor network, a load sensor network and a display device. Sensing system also includes a central processor which is electrically coupled in a conventional manner to the range sensor network, load sensor network and display device for each overhead luggage storage bin. Central processor is also conventionally coupled to attendant module and to a wireless interface. Sensing system operates in a similar manner to sensing system of the first embodiment shown in but with central processor performing the processing for each overhead luggage storage bin (instead of having separate processors for each storage bin as in the embodiment.

a flowchart is shown of a method for displaying storage capacity status information for one or more passenger storage bins in an aircraft. First, at step, the weight of items within the associated passenger storage bin is determined for each of the passenger storage bins. Next, at step, an amount of empty space available within the associated passenger storage bin is determined for each of the passenger storage bins. Thereafter, at step, a calculation is made based upon the weight of items within the associated passenger storage bin and the amount of empty space available within the associated passenger storage bin, whether or not the associated storage bin is filled to capacity for each of the passenger storage bins. Finally, at step, a visual indication is provided indicating whether or not the associated storage bin is filled to capacity for each of the passenger storage bins.

Although the present disclosure has been particularly shown and described with reference to the preferred embodiments and various aspects thereof, it will be appreciated by those of ordinary skill in the art that various changes and modifications may be made without departing from the spirit and scope of the disclosure. It is intended that the appended claims

be interpreted as including the embodiments described herein, the alternatives mentioned above, and all equivalents thereto.

There were discussed recommendations of FAA and IATA for carry-on bag size. These recommendations have “regulatory approach” and are aimed on necessary level of onboard baggage load for already existing overhead bins dimensions providing.

Analysis of low-cost carriers’ preferences for bags' length, total length and volume shown some semblance and distinction in requirement for carry-on bags size. Operators from some regions have typical recommendation for bags size. Due to that these carriers provide a standard requirement for luggage. This standards awareness will be useful for aircraft and aircraft equipment designers. Such “adaptive approach” for overhead bins could give flexibility for passenger cabin layout designing.

Looking at the analysis which was made and taking we can see that most usual baggage size almost coincide with baggage sizes, which were chosen in IATA’s cabin ok initiative (55x35x20). So it is possible to make conclusion that the best sizes for overhead storage bin that will be designed is equal to (55x35x20).

### **3.4 Calculation for strength of overhead storage bin bottom part**

The mass of baggage which could be stored in overhead bin is usually limited by 12 kilograms.

General Provisions (a) The design of the aircraft should be such that, even if the aircraft is damaged, the safety conditions for all passengers and crew members are ensured in the conditions of emergency landing on the ground or on the water given below.

(b) The design of the aircraft should be such that passengers and crew members have a real opportunity to avoid serious injuries in an emergency landing with minor damage when:

- (1) Seats, seat belts and other safety equipment are correctly used.
- (2) The chassis is removed (when possible); and



(3) The calculated inertial forces, corresponding to the accelerations, operate separately for the passengers and crew members, as follows:

(i) upwards 3.0g;

(ii) forward 9.0 g;

(iii) towards 3.0g for the airframe and 4.0g for the seats and their anchorages;

(iv) downward to 6.0g;

(v) backwards 1.5g.

(c) For equipment, goods in a passenger cabin and any other large masses, the following shall be accepted:

(1) These masses shall be located so that, when they are separated, they:

(i) do not cause direct injury to passengers and crew members;

(ii) no fuel tanks or pipelines were punctured or fire or explosion resulted from the destruction of nearby systems;

(iii) did not block any life-saving appliances intended for use in an emergency landing.

(2) If such an arrangement is not possible (for example, the engine and the APU are located in the fuselage), each such mass and its attachment points must

withstand loads up to the points given in paragraph (b) (3) of this paragraph. The local strength of the attachment points of these masses should also be provided for loads of 1.33 times greater if they are subject to considerable wear and tear with frequent permutations (for example, frequently replaced interior items).

(d) The seats and individual weights (and their supporting structure), under the influence of loads up to the points specified in paragraph (b) (3), shall not be deformed so as not to interfere with the subsequent rapid evacuation of passengers and crew.”

According to this we will use acceleration of 6 units and safety factor of 1.33.

Lets consider the overhead storage bin bottom part as beam on to supports. The scheme for this case will be as shown on figure 3.6 (<https://patentimages.storage.googleapis.com> .)

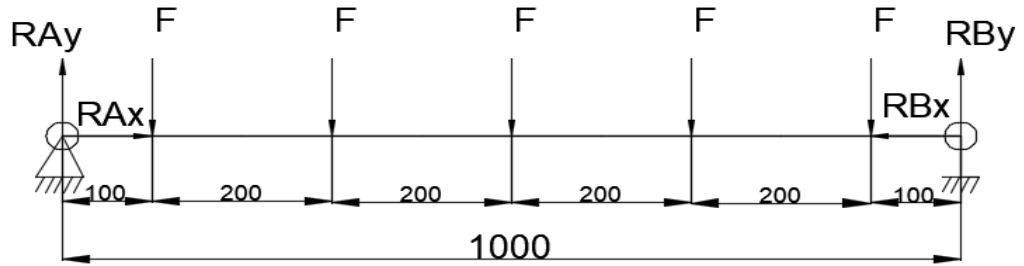

Figure. 3.8 - Scheme for strength calculation of overhead Storage bin bottom part

On this figure the outer forces “F” represents the loads from baggage.

$$F = m \cdot n \cdot g = 12 \cdot 6 \cdot 9.81 = 706.32(N);$$

here m is mass of one bag, n-units of overload, g-gravity acceleration.

$R_{Ay}$ ,  $R_{Ax}$ ,  $R_{By}$ ,  $R_{Bx}$ , are supports reactions.

It is obvious that reactions in x directions are equal to zero because there is no outer forces, which have non-zero projection on x-axis:

$$R_{Ax}=0;$$

$$R_{Bx}=0.$$

According to Newton’s 2-nd law, sum of forces projections on y-axis is equal to zero:

$$R_{Ay}+R_{By}-5F=0.$$

As beam and load on it is simetrial, we can assume that suppots reaction are equal each other:

$$R_{Ay}=R_{By}.$$

So we can calculate reactions:

$$R_{Ay}=5 \cdot F/2=5 \cdot 706.32/2=1765.8(N);$$

$$R_{Ay}= R_{By}=1765.8(N).$$

Next step is to calculate shear loads and bending moments in each section.

There is 7 points in which the rate of change of shear load or bending moment is changes. Correspondently there is 6 sections that are shown on figure 3.7 (Zhitomirskiy G.I. Aircraft design: A textbook for students of aviation specialties of universities. -M.: Mashinostroenie,)

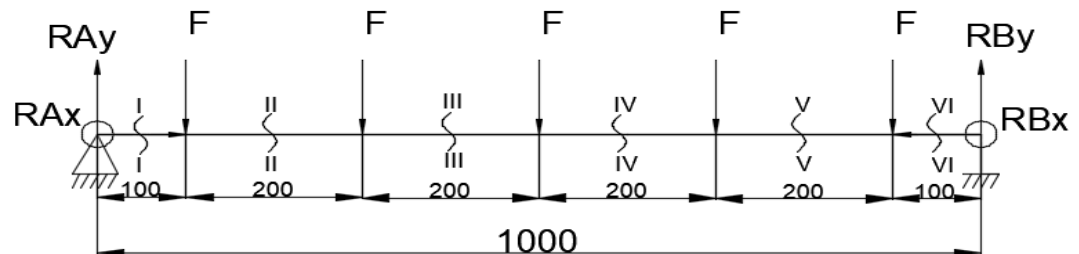

Figure 3.9 - Principal Sections of Beam.

Calculation of loads in each sections looks as next:

Lets consider the increment of shear force and bending moment at parts of beam, the results of internal forces are presented in the table 3.1.

Table 3.1 – The results of calculation of internal forces for the diagrams

Section of beam, m	Coordination, m	Shear force, N	Bending moment, Nm
$0 < x < 0.1$	$x=0$	$Q=RAy=1765.8$	$Mx1= RAy \cdot x=1765.8 \cdot 0=0$
	$x=0.1$	$Q=RAy=1765.8$	$Mx= RAy \cdot x=1765.8 \cdot 0.1=176.58$
$0.1 < x < 0.3$	$x=0.1$	$Q=RAy=1765.8$	$Mx=Ray \cdot x-f \cdot (x-0.1)=1765.8 \cdot 0=0$
	$X=0.3$	$Q=RAy-F=1765.8$	$Mx= RAy \cdot x-F \cdot (x-0.1)=1765.8 \cdot 0=0$
$0.3 < x < 0.5$	$X=0.3$	$Q=RAy-2F=1765.8$	$Mx= RAy \cdot x-F \cdot (x-0.1)-F \cdot (x-0.2)=1765.8 \cdot 0=0;$

	$x=0.5$	$Q=RAy-2F=1765.8$	$Mx= RAy \cdot x - F \cdot (x-0.1) - F \cdot (x-0.3) = 1765.8 \cdot 0 = 0.$
$0.5 < x < 0.7$	$x=0.5$	$Q=RAy-3F=1765.8$	$Mx= RAy \cdot x - F \cdot (x-0.1) - F \cdot (x-0.3) - F \cdot (x-0.5) = 1765.8 \cdot 0 = 0$
	$x=0.7$	$Q=RAy-3F=1765.8$	$Mx= RAy \cdot x - F \cdot (x-0.1) - F \cdot (x-0.3) - F \cdot (x-0.5) = 1765.8 \cdot 0 = 0;$
$0.7 < x < 0.9$	$x=0.7$	$Q=RAy-4F=1765.8$	$Mx= RAy \cdot x - F \cdot (x-0.1) - F \cdot (x-0.3) - F \cdot (x-0.5) - F \cdot (x-0.7) = 1765.8 \cdot 0 = 0$
	$x=0.9$	$Q=RAy-4F=1765.8$	$Mx= RAy \cdot x - F \cdot (x-0.1) - F \cdot (x-0.3) - F \cdot (x-0.5) - F \cdot (x-0.7) = 1765.8 \cdot 0 = 0;$
$: 0.9 < x < 1$	$x=0.9$	$Q=RAy-5F=1765.8$	$Mx= RAy \cdot x - F \cdot (x-0.1) - F \cdot (x-0.3) - F \cdot (x-0.5) - F \cdot (x-0.7) - F \cdot (x-0.9) = 1765.8 \cdot 0 = 0$
	$x=1$	$Q=RAy-5F=1765.8$	$Mx= RAy \cdot x - F \cdot (x-0.1) - F \cdot (x-0.3) - F \cdot (x-0.5) - F \cdot (x-0.7) - F \cdot (x-0.9) = 1765.8 \cdot 0 = 0$

Using this calculation or using Zhuravsky rule it is possible to draw graph of loads as shown on figure 3.10

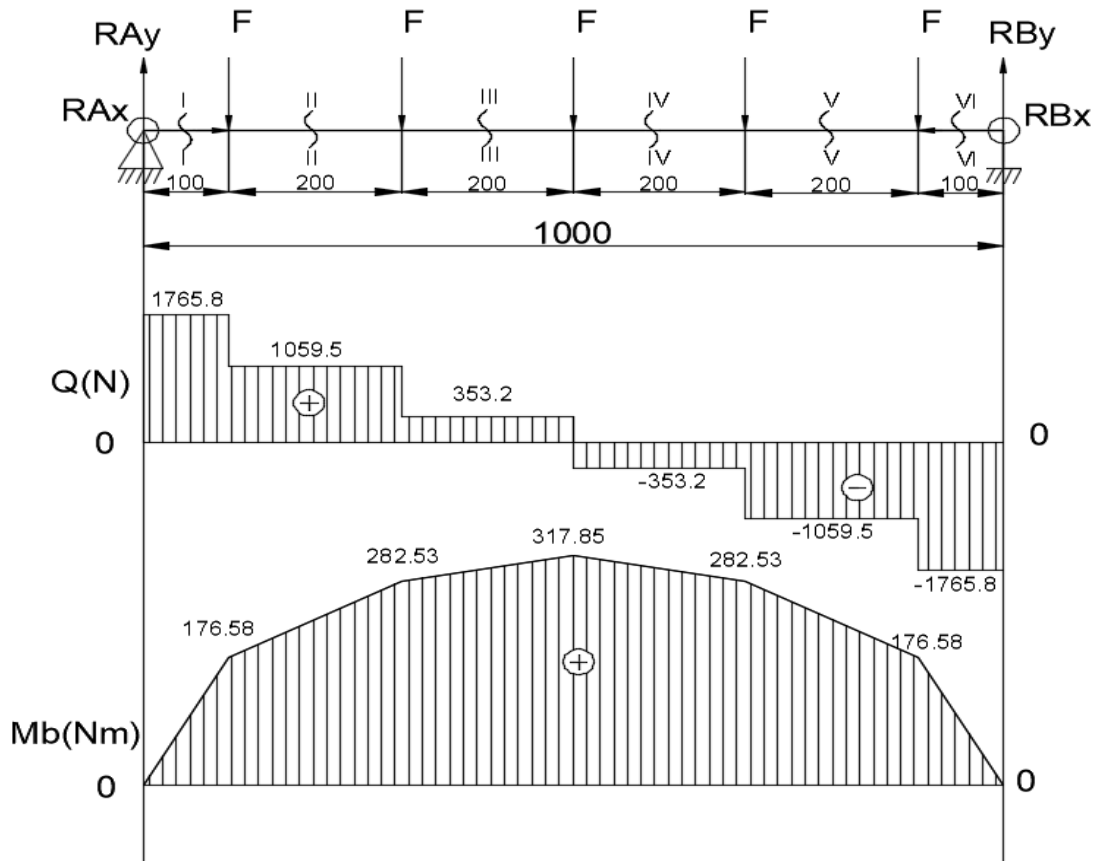

Figure 3.10 - Graph of loads

Next step is to determine the maximum stresses in the cross-section of bin.

For strength calculation we need to define moments of inertia. For this we can use CAD program, where we should build the explored cross-section and then using build-in instrument define main axis and moments of inertia. Results is shown on figure 3.10(Zhitomirskiy G.I. Aircraft design: A textbook for students of aviation specialties of universities. -M.: Mashinostroenie,)

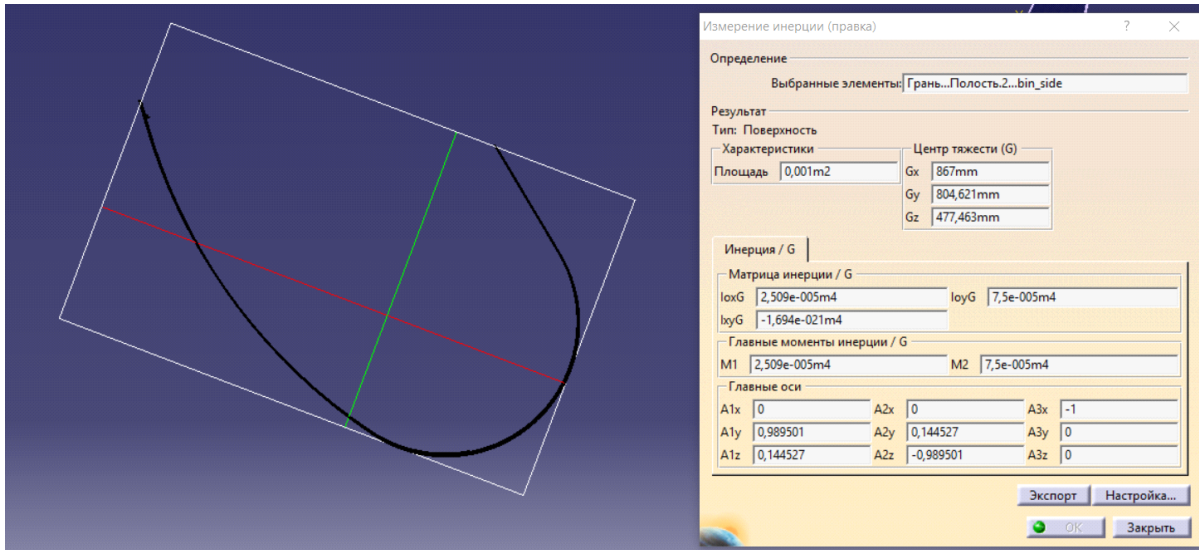

Figure 3.11 – determination of moments of inertia using CAD program

We obtained main moments of inertia. The thickness of profile was chosen 1mm. Really, the thickness of overhead bins walls is bigger, but it is made from honeycomb structure and normal forces to the considered profile are withstands by walls of honeycomb structure. The plane of moments did not coincide with any plane of main moment of inertia so this case is called oblique banding. For this case it is possible to use next formula, where  $\alpha = 14,24^\circ$  is angle between main axis and lateral axis of airplane,  $J_y = 7,5 \cdot 10^{-5} (m^4)$ ,  $J_z = 2,5 \cdot 10^{-5} (m^4)$  - are main moments of inertia,  $y_{\max} = 290,21 (mm)$   $z_{\max} = 453,67$  - distance from main moment of inertia axis and most distant point of cross-section from axis.

$$\sigma_{\max} = M \cdot \left( \frac{y_{\max} \cdot \cos \alpha}{J_z} + \frac{z_{\max} \cdot \sin \alpha}{J_y} \right) =$$

$$= 317,85 \cdot \left( \frac{0,29 \cdot \cos(14,24)}{2,5 \cdot 10^{-5}} + \frac{0,45 \cdot \sin(14,24)}{7,5 \cdot 10^{-5}} \right) = 4 (MPa)$$

The ultimate stress of fiber glass  $\sigma_u$  is equal to 1400 MPa, so the safety coefficient is largely bigger than 1,33 required

### **Conclusion to part 3**

The preliminary design of a smart aircraft overhead luggage bin system was developed in order to create a displaying storage capacity status information for one or more passenger storage bin in an aircraft. Which was based on load sensors mechanism that are coupled to each passenger storage bin and provide an output signal proportional to a weight of items with the bin by the help of strain gage. Also I analyzed a suitable size for overhead storage bin that I have chosen. And the mechanism for opening overhead bin was created, and checked using CAD program. Besides that, using CAD program integrity of designed overhead storage bin and its ergonomics characteristic was checked as well.

## **PART 4**

### **Labor Protection**

This chapter is dedicated to providing safe working conditions while working on diploma project. Therefore, two workplaces are used when carrying out all the necessary procedures of the experiment.

The first one is mechanical laboratory, used for the pure test conduction of the duralumin specimens while the second one is open space personal computer workplace of the engineer, where the CAE simulation is performed.

In this part stress engineer working in front of a computer is considered as the subject of the work. Consequently, the office room layout working conditions will be analyzed.

This section lists the dangerous factors in office conditions. The specified measures for protection against these factors, the recommendations for Production of equipment safety and the calculation of artificial lighting are given.

#### **4.2 Analysis of the working conditions**

Analyzing the working conditions in the workplace includes the following aspects:

##### **4.2.1 Organizing the workspace of the engineer**

Stress engineer workplace is located in the office, which is the part of the engineering design center. There are two adjacent workplaces in the room. They are quite similar except for the presence of a laptop on one side and personal computer on the other.

Geometrical sizes of the room are 3 m x 4 m x 3 m (length x width x height). Therefore, room area is 12 m<sup>2</sup> and airspace is 36 m<sup>3</sup>. All these building parameters are approved by the state construction rules of Ukraine (ДБН В.2.2–28–2010) [15]. Generally, the size of the office room is proportional to the number of engineers sitting in it. There is a plenty of room layouts, but fundamental principles for all of them are the same. It



can be an open space zone, where the engineers' workplaces are separated with partitions and it can be an enclosed room, usually termed as office.

Attached in the Fig 1 below is an example of the workplace office

Figure 1 - office workplace



#### **4.2.2 Harmful and dangerous factors list**

According to the standard ГОСТ 12.0.003-74 «Гігієнічна класифікація праці за показниками шкідливості та небезпечності факторів виробничого середовища, важкості та напруженості трудового процесу» [18], the following harmful and dangerous factors take place during worktime operation:

1. lack or absence of natural light,
2. Insufficient lightening of the work area
3. Increased or decreased air temperature of the working area;
4. Increased vibration level;
5. Increased level of ionizing radiation in the working area;

Since PC operation take the overwhelming majority of the working time, the sensory load takes place. But in this case it is not considered as a hazardous factor.

#### **4.2.3 Harmful and dangerous factors analysis**

Lamplight. The fluorescent lamps are used in considered working room. Two windows of size 2 m × 1.5 m serve as a source of natural light. They have a three layers of glass and the metal frame. Daylight factor ~ 1.7%. The actual value of light is 200-250 lx.

In order to provide the artificial lighting in these areas, the light sources with sufficiently high efficiency should be located in general lighting lamps, which are located on the working places in a uniform rectangular order. LED lamps will be the best choice in these areas because of their highest output of light. Artificial lighting should provide the workplace illumination of 300-500 lx. Artificial lighting influences engineer's sight significantly. The lack of illumination causes the additional tension and can even lead to the visual deterioration in the worst cases. So, it is very important to take care of our eyes, because they are loaded the most of all other parts of the body.

Artificial lighting is used as a partial amount of natural light. These general premises used artificial lighting. Only artificial light can be improved normally:

1. Fluorescent lamps of LB type are used as a source of artificial light;
2. Improvement of working room lightning requires the reconstruction of installed artificial lightning. Some of these approaches can be the usage of different types of lamps, changing its capacity and quantity. The LED lamps was chosen to install. Unlike the fluorescent lamps, the LED lamps are able to convert directly the electrical current into the light and, theoretically, without a great energy loss. LED are poor heating and they emit a narrow spectrum, and UV and IR radiation are usually absent. LED are mechanically strong and extremely reliable. Its service life can reach 100 thousand hours, which is almost 5.10 times higher than in fluorescent lamps. Finally, LED – low voltage appliance, so they are relatively safe. It is necessary to use the system switches in order to regulate the artificial lightning intensity depending on the intensity of natural light and your own needs.

To ensure optimal performance and health preservation of engineer, during the work shift regular breaks should be determined and installed. Time regulated breaks during the work shift should be set depending on its duration, type of work and employment category. Continuous operation without interruption should not exceed 2 hours. At 8 – hour work shift and work on the PC regulated break should be set: for category I work – 2 hours from the beginning of the shift and every 2 hours after the lunch break of 15 minutes each. Some exercises on eyes can be carried out for eye fatigue prediction.

Artificial lighting is used as a partial amount of natural light. These general premises used artificial lighting. Only artificial light can be improved normally:

3. Fluorescent lamps of LB type are used as a source of artificial light;

4. Improvement of working room lightning requires the reconstruction of installed artificial lightning. Some of these approaches can be the usage of different types of lamps, changing its capacity and quantity. The LED lamps was chosen to install. Unlike the fluorescent lamps, the LED lamps are able to convert directly the electrical current into the light and, theoretically, without a great energy loss. LED are poor heating and they emit a narrow spectrum, and UV and IR radiation are usually absent. LED are mechanically strong and extremely reliable. Its service life can reach 100 thousand hours, which is almost 5.10 times higher than in fluorescent lamps. Finally, LED – low voltage appliance, so they are relatively safe. It is necessary to use the system switches in order to regulate the artificial lightning intensity depending on the intensity of natural light and your own needs.

Microclimate: temperature, humidity, air velocity. According to the required standards ДСН 3.3.6.042–99 “Санітарні норми мікроклімату виробничих приміщень” [19], depending on the complexity of work, engineer designers categorized IB (light physical work). The optimal values of temperature, relative humidity and air velocity of the working area of business premises are shown at Table

Table 4.2 – Actual values of temperature, relative humidity and air speed

Season	Category of works	Air temperature, C°	Relative humidity, %	Speed, m/s
Cold	Easy –1 b	18	35	0.25

To meet the humidity increasing in the room with computers equipment humidifiers should be used, which also need to be refueled every day by distilled water. Reducing the negative impact of microclimate is achieved by efficient ventilation done and also heating.

It is important to provide the office with an advanced high tech ventilation system. The sense of it is that it can regulate the above mentioned parameters in two ways: automatically and manually. it however has the control panel allowing to change these parameters in each separate unit of the office . Air filters must be mounted to prevent the inlet of different biological hazards from the outside. The continuous airflow in the open space positively stimulates the human brain on working, however the lack of the fresh air can lead to serious health problems along with low working effectively.

#### **4.2.4 The Artificial lighting calculation**

A Normal room illumination ( $E_{min}$ ) depends on the level of visual work performed in this room, which in turn is determined by the minimum size of the object of discrimination. For general lighting engineer at the lowest room illumination by ДБН В.2.5–28–2018 “Природне і штучне освітлення” [22] of at least 400 lx (lux). The actual value of light is 200 – 250 lx. Total light output is given by:

$$E_{gen} = \frac{E_n \cdot S \cdot k_1 \cdot k_2}{V}$$

where  $E_n$  – normalized illumination ( $E_n=400lx$ );

$S$  – area of application;

$k_1$  – Coefficient taking into account the aging of lamps and lighting pollution ( $k_1=1.2$ );

$k_2$  – Coefficient taking into account the uneven illumination space ( $k_2= 1.1$ );

$V$  – Ratio of luminous flux, defined according to the reflection coefficient of walls, work surfaces, ceilings, room geometry and types of lamps.

Room size up:  $A = 3$  m,  $B = 4$  m,  $H = 3$ m.

$$S = A \cdot B = 3 \cdot 4 = 12 \text{ m}^2$$

Choose the table using the light flux ratios:

1. Reflection coefficient of whitewashed ceiling ( $R_{\text{ceiling}} = 70\%$ );
2. Index of refraction of white walls ( $R_{\text{wall}} = 55\%$ );
3. Reflection coefficient from the dark hardwood floors ( $R_{\text{floor}} = 10\%$ );
4. Index space ( $i = \frac{A \cdot B}{h_p \cdot (A+B)}$ ).

$$h_p = H - h_n$$

where  $h_n$ — work surface height over the floor ( $h_n=0.7 \text{ m}$ ).

Defining the room rate:

$$h_p = 3 - 0.7 = 2.3 \text{ m}$$

The utilization of light flux:

$$i = \frac{3 \cdot 4}{2.3 \cdot (3+4)} \approx 0.75.$$

Now we define the value of the total luminous flux: ( $V=0.7$ )

$$E_{\text{gen}} \frac{400 \cdot 12 \cdot 1.2 \cdot 1.1}{0.7} = 9051 \text{ lm}$$

To ensure total artificial lighting, selected LED bulbs LED-T8SE-180 and replace fluorescent lamps 18W 990 lm. Luminous flux of one lamp LED-T8SE-180 (20W.). Thus,  $E_l=1650 \text{ lm}$ .

Now we define the number of lamps required to illuminate the room:

$$N = \frac{E_{\text{gen}}}{E_l} = \frac{9051}{1650} = 6 \text{ lamps}$$

Thus, to provide light  $E_{\text{gen}}=9051 \text{ lm}$  output the 6 LED lamps must be used instead of 10 fluorescent lamps. Put in 2 rows. Power of 10 fluorescent lamps:

$$W_{\text{gen}} = W_N \cdot N = 18 \cdot 10 = 180 \text{ W}$$

Savings from the use of LED lamps.

$$N = W_{\text{gen}} / (N_{\text{LED}} \cdot P_{\text{LED}}) = 180 / (6 \cdot 20) = 1.5$$

Therefore, we can deduce from the calculations that the usage of LED lamps is much more efficient and advised.

### **4.3 General production safety requirements in equipment design and production of equipment**

- 3.1) Inform Supervisors of Unsafe Conditions.
- 3.2) Use Equipment, Machines, and Tools Properly;
- 3.3) Misusing tools and machines is the most prevalent cause of workplace injuries.
- 3.3) Wear Safety Equipment (PPE)
- 3.4) When cleaning up messes and using equipment, make sure you wear the proper safety equipment
- 3.5) Prevent Slips and Trips
- 3.6) Keep Work Areas and Emergency Exits Clear
- 3.7) Eliminate Fire Hazards
- 3.8) Avoid Tracking Hazardous Materials
- 3.9) Prevent Objects from Falling

---

- 3.10) Use Correct Posture when Lifting
- 3.11) Take Work Breaks from Time to Time

### **4.4 Safety requirements before starting work**

- 4.1) All employees will wear all required safety gear, safety glasses, and safety clothing for their job/position while at their workstation.
- 4.2) All employees working around moving machinery are prohibited from wearing loose clothing or loose jewelry.
- 4.3) All employees working around moving machinery must have long hair tied back where it cannot fall forward or be caught in the machinery.
- 4.4) All tools will be in use or will be stored at their proper location at all times, no tools are to be left in any location where they are not being used or being stored.

4.5) All equipment, tools and machinery are to be kept clean and in full working condition, with any defects being immediately reported to maintenance.

4.6) The instruction manuals for all machinery must be readily available for review.

4.7) All equipment and machinery is to be shut down when not in use.

4.8) All presses and machinery will require two hand operation to keep fingers and hands away from moving part.

4.9) All machinery is to have the manufacturer's installed safety guards.

4.10) No machinery is to be modified by any employee who is not specifically trained in the technical aspects of the machinery.

#### **4.5 General safety requirements during production of equipment**

5.1) Never take shortcuts.

5.2) Clean and organize your workspace.

5.3) Ensure a clear and easy route to emergency exits and equipment.

5.6) Be alert and awake on the job.

5.7) Be attentive at all times to your work surroundings.

5.8) When in doubt, contact your supervisor or manager for instruction, guidance, or training.

5.9) Never take risks when it comes to safety.

5.10) Obey safety signs, stickers, and tags.

5.11) Take short breaks when you keep up a repetitive motion for a long period of time, and sit, stand, or walk with good posture.

5.12) Report serious injuries immediately to a supervisor and get emergency assistance.

5.13) Always keep the communication lines open with your co-workers, employers, or employees in order to promote and maintain a safe environment.

5.14) Immediately notify others of any (new or old) hazards that you perceive.

5.15) Be alert to hazards that could affect anyone— not just yourself; in this respect, maintain a team mentality at all times.

5.16) Fire extinguishers must be available and readily attainable.

5.17) First aid kits must be available and readily attainable.

5.18) Never remove or tamper with safety devices.

#### **4.6 Safety requirements after production**

6.1) Clean your tools and keep them in good working order.

6.2) Organize your tools and don't be careless; someone could easily slip or get hit due to a misplaced object.

6.3) Turn off machines and equipment before you even consider cleaning, un-jamming, oiling, adjusting, or moving them.

6.4) Wash face and hands with warm water and soap/take a shower if workplace has such provision after production.

6.7) Place the instrument in the place provided for this purpose after usage

#### **4.7. Safety requirements at emergency situations during production**

A production company should have an emergency plan mapped out incase such a scenario occurs. The lack of an emergency plan could lead to severe losses such as multiple casualties and possible financial collapse of the organization.

7.1) The emergency plan includes:

All possible emergencies, consequences, required actions, written procedures, and the resources available.

Detailed lists of emergency response personnel including their cell phone numbers, alternate contact details, and their duties and responsibilities.

Floor plans.

Large scale maps showing evacuation routes and service conduits (such as gas and water lines).



Objective: The objective is a brief summary of the purpose of the plan; that is, to reduce human injury and damage to property and environment in an emergency. It also specifies those staff members who may put the plan into action.

7.2) Organization: One individual should be appointed and trained to act as Emergency Co-coordinator as well as a "back-up" co-coordinator. However, personnel on site during an emergency are key in ensuring that prompt and efficient action is taken to minimize loss

Procedures: Many factors determine what procedures are needed in an emergency situation during production, such as:

Nature of emergency.

Degree of emergency.

Natural hazards, such as floods or severe storms, often provide prior warning. The plan should take advantage of such warnings with, for example, instructions on sand bagging, removal of equipment to needed locations, providing alternate sources of power, light or water, extra equipment, and relocation of personnel with special skills. Phased states of alert allow such measures to be initiated in an orderly manner.

7.2) The following are should be done:

Identify evacuation routes, alternate means of escape, make these known to all staff; keep the routes unobstructed.

Specify safe locations for staff to gather for head counts to ensure that everyone has left the danger zone. Assign individuals to assist employees with disabilities

7.3) Testing and Revision: Exercises and drills may be conducted to practice all or critical portions (such as evacuation) of the plan.

7.4) Emergency exits from the building, de-energize, close windows and close doors.

7.4) Leave the building and stay in the evacuation zone

#### **Conclusion to part 4**

For a designer and the production team it is necessary for proper lightening of both the natural and also the artificial source of a recommended amount is important to ensure effectiveness and for the safety of the designer and the production team, it is also necessary to consider the safety requirements necessary for production before starting. Another key factor is to plan for emergency situations for a better risk management to avoid fatalities.

## **PART 5**

### **ENVIRONMENTAL PROTECTION**

This chapter of the project embodies the environmental protection analysis and we will be discussing the plastic utilization.

Plastics have transformed everyday life; usage is increasing and annual production is likely to exceed 300 million tonnes by 2010. It is evident that plastics bring many societal benefits and offer future technological and medical advances. However, concerns about usage and disposal are diverse and include accumulation of waste in landfills and in natural habitats, physical problems for wildlife resulting from ingestion or entanglement in plastic, the leaching of chemicals from plastic products and the potential for plastics to transfer chemicals to wildlife and humans. However, perhaps the most important overriding concern, which is implicit throughout this volume, is that our current usage is not sustainable.

This Part of the project synthesizes current understanding of the benefits and concerns surrounding the use of plastics and looks to challenges, opportunities and priorities for the future.

## **5.1 Utilization of plastics as materials**

Plastics are inexpensive, lightweight, strong, durable, corrosion-resistant materials, with high thermal and electrical insulation properties. The diversity of polymers and the versatility of their properties are used to make a vast array of products that bring medical and technological advances, energy savings and numerous other societal benefits as a consequence, the production of plastics has increased substantially over the last 60 years from around 0.5 million tonnes in 1950 to over 260 million tonnes today. In Europe alone the plastics industry has a turnover in excess of 300 million euros and employs 1.6 million people. Almost all aspects of daily life involve plastics, in transport, telecommunications, clothing, footwear and as packaging materials that facilitate the transport of a wide range of food, drink and other goods. There is considerable potential for new applications of plastics that will bring benefits in the future, for example as novel medical applications, in the generation of renewable energy and by reducing energy used in transport.

Virgin plastic polymers are rarely used by themselves and typically the polymer resins are mixed with various additives to improve performance. These additives include inorganic fillers such as carbon and silica that reinforce the material, plasticizers to render the material pliable, thermal and ultraviolet stabilizers, flame retardants and colourings. Many such additives are used in substantial quantities and in a wide range of products. Some additive chemicals are potentially toxic (for example lead and tributyl tin in polyvinyl chloride, PVC), but there is considerable controversy about the extent to which additives released from plastic products (such as phthalates and bisphenol A, BPA) have adverse effects in animal or human populations. The central issue here is relating the types and quantities of additives present in plastics to uptake and accumulation by living organisms. Additives of particular concern are phthalate plasticizers, BPA, brominated flame retardants and anti-microbial agents. BPA and phthalates are found in many mass-produced products including medical devices, food packaging, perfumes, and cosmetics, toys, flooring materials, computers and CDs and can represent a significant content of the plastic. For instance, phthalates can constitute a substantial proportion, by weight, of PVC, while BPA is the monomer used for production of polycarbonate plastics as well as an additive used for production of PVC. Phthalates can leach out of products because they are not chemically bound to the plastic matrix, and they have attracted particular attention because of their high production volumes and wide usage. Phthalates and BPA are detectable in aquatic environments, in dust and, because of their volatility, in air there is considerable concern about the adverse effects of these chemicals on wildlife and humans. In addition to the reliance on finite resources for plastic production, and concerns about additive effects of different chemicals, current patterns of usage are generating global waste management problems. show that plastic wastes, including packaging, electrical equipment and plastics from end-of-life vehicles, are major components of both household and industrial wastes; our capacity for disposal of waste to landfill is finite and, in some locations, landfills are at, or are rapidly approaching, capacity. So, from several perspectives it would seem that our current use and disposal of plastics is the cause for concern.

## **5.2 The effect of plastic debris on environment and wildlife**

There are some accounts of effects of debris from terrestrial habitats, for example ingestion by the endangered California condor, but however, the vast majority of work describing environmental consequences of plastic debris is from marine settings and more work on terrestrial and freshwater habitats is needed. Plastic debris causes aesthetic problems, and it also presents a hazard to maritime activities including fishing and tourism. Discarded fishing nets result in ghost fishing that may result in losses to commercial fisheries. Floating plastic debris can rapidly become colonized by marine organisms and since it can persist at the sea surface for substantial periods, it may subsequently facilitate the transport of non-native or 'alien' species. However, the problems attracting most public and media attention are those resulting in ingestion and entanglement by wildlife. Over 260 species, including invertebrates, turtles, fish, seabirds and mammals, have been reported to ingest or become entangled in plastic debris, resulting in impaired movement and feeding, reduced reproductive output, lacerations, ulcers and death. The limited monitoring data we have suggest rates of entanglement have increased over time. A wide range of species with different modes of feeding including filter feeders, deposit feeders and detritivores are known to ingest plastics. However, ingestion is likely to be particularly problematic for species that specifically select plastic items because they mistake them for their food. As a consequence, the incidence of ingestion can be extremely high in some populations. For example, 95 per cent of fulmars washed ashore dead in the North Sea have plastic in their guts, with substantial quantities of plastic being reported in the guts of other birds, including albatross and prions. There are some very good data on the quantity of debris ingested by seabirds recorded from the carcasses of dead birds. This approach has been used mostly to monitor temporal and spatial patterns in the abundance of sea-surface plastic debris on regional scales around Europe.

An area of which is of particular concern is the abundance of small plastic fragments or micro plastics. Fragments as small as 1.6  $\mu\text{m}$  have been identified in some marine habitats,

and it seems likely there will be even smaller pieces below current levels of detection. A recent workshop convened in the USA by the National Oceanic and Atmospheric Administration concluded that micro plastics be defined as pieces <5 mm with a suggested lower size boundary of 333  $\mu\text{m}$  so as to focus on micro plastics that will be captured using conventional sampling approaches. However, we consider it important that the abundance of even smaller fragments is not neglected. Plastic fragments appear to form by the mechanical and chemical deterioration of larger items. Alternative routes for micro plastics to enter the environment include the direct release of small pieces of plastics that are used as abrasives in industrial and domestic cleaning applications (for example shot blasting or scrubbers used in proprietary hand cleansers) and spillage of plastic pellets and powders that are used as a feedstock for the manufacture of most plastic products. Data from shorelines, from the open ocean and from debris ingested by seabirds, all indicate that quantities of plastic fragments are increasing in the environment, and quantities on some shores are substantial (>10% by weight of strandline material; Laboratory experiments have shown that small pieces such as these can be ingested by small marine invertebrates including filter feeders, deposit feeders and detritivores, while mussels were shown to retain plastic for over 48 days. However, the extent and consequences of ingestion of micro plastics by natural populations are not known.

More work will be needed to establish the full environmental relevance of plastics in the transport of contaminants to organisms living in the natural environment, and the extent to which these chemicals could then be transported along food chains. However, there is already clear evidence that chemicals associated with plastic are potentially harmful to wildlife. Data that have principally been collected using laboratory exposures are summarized by. These show that phthalates and BPA affect reproduction in all studied animal groups and impair development in crustaceans and amphibians. Molluscs and amphibians appear to be particularly sensitive to these compounds and biological effects have been observed in the low  $\text{ng l}^{-1}$  to  $\mu\text{g l}^{-1}$  range. In contrast, most effects in fish tend to occur at higher concentrations. Most plasticizers appear to act by interfering with hormone

function, although they can do this by several mechanisms). Effects observed in the laboratory coincide with measured environmental concentrations, thus there is a very real probability that these chemicals are affecting natural populations. BPA concentrations in aquatic environments vary considerably, but can reach  $21 \mu\text{g l}^{-1}$  in freshwater systems and concentrations in sediments are generally several orders of magnitude higher than in the water column. For example, in the River Elbe, Germany, BPA was measured at  $0.77 \mu\text{g l}^{-1}$  in water compared with  $343 \mu\text{g kg}^{-1}$  in sediment (dry weight). These findings are in stark contrast with the European Union environmental risk assessment predicted environmental concentrations of  $0.12 \mu\text{g l}^{-1}$  for water and  $1.6 \mu\text{g kg}^{-1}$  (dry weight) for sediments. Also, phthalates and BPA can bio accumulate in organisms, but there is much variability between species and individuals according to the type of plasticizer and experimental protocol. However, concentration factors are generally higher for invertebrates than vertebrates, and can be especially high in some species of molluscs and crustaceans. While there is clear evidence that these chemicals have adverse effects at environmentally relevant concentrations in laboratory studies, there is a need for further research to establish population-level effects in the natural environment, to establish the long-term effects of exposures (particularly due to exposure of embryos), to determine effects of exposure to contaminant mixtures and to establish the role of plastics as sources (albeit not exclusive sources) of these contaminants.

### **5.3 The effect of plastic in our natural environment**

Substantial quantities of plastic have accumulated in the natural environment and in landfills. Around 10 per cent by weight of the municipal waste stream is plastic. Discarded plastic also contaminates a wide range of natural terrestrial, freshwater and marine habitats, with newspaper accounts of plastic debris on even some of the highest mountains., also by comparison with the marine environment, there is a distinct lack of data on the accumulation of plastic debris in natural terrestrial and freshwater habitats. There are accounts of inadvertent contamination of soils with small plastic fragments as a consequence of

spreading sewage sludge of fragments of plastic and glass contaminating compost prepared from municipal solid waste and of plastic being carried into streams, rivers and ultimately the sea with rain water and flood events. However, there is a clear need for more research on the quantities and effects of plastic debris in natural terrestrial habitats, on agricultural land and in freshwaters. Inevitably, therefore, much of the evidence presented here is from the marine environment. From the first accounts of plastic in the environment, which were reported from the carcasses of seabirds collected from shorelines in the early 1960s, the extent of the problem soon became unmistakable with plastic debris contaminating oceans from the poles to the Equator and from shorelines to the deep sea. Most polymers are buoyant in water, and since items of plastic debris such as cartons and bottles often trap air, substantial quantities of plastic debris accumulate on the sea surface and may also be washed ashore. As a consequence, plastics represent a considerable proportion (50–80%) of shoreline debris. Quantities are highly variable in time and space, but there are reports of more than 100 000 items  $\text{m}^{-2}$  on some shorelines and up to 3 520 000 items  $\text{km}^{-2}$  at the ocean surface Gyres and oceanic convergences appear to be particularly contaminated, as do enclosed seas such as the Mediterranean. Despite their buoyant nature, plastics can become fouled with marine life and sediment causing items to sink to the seabed. Taking into example, shallow seabed in Brazil were more heavily contaminated than the neighbouring shorelines, indicating that the seabed may be an ultimate sink even for initially buoyant marine debris.

In some locations around Europe, it has been suggested that quantities on the seabed may exceed 10 000 items  $\text{ha}^{-1}$ , and debris has even been reported more than a 1000 m below the ocean surface, including accounts of inverted plastic bags passing a deep-sea submersible like a ghost assembly. Quantitative data on the abundance of debris on the seabed are still very limited, but there are concerns that degradation rates in the deep sea will be especially slow because of darkness and cold.

Monitoring the abundance of debris is very important as it assists in establishing rates of accumulation and the effectiveness of any remediation measures. Most studies assess the



abundance of all types of anthropogenic debris including data on plastics and/or plastic items as a category. In general, the abundance of debris on shorelines has been extensively monitored, in comparison to surveys from the open oceans or the seabed. In addition to recording debris, there is a need to collect data on sources; for plastic debris this should include discharges from rivers and sewers together with littering behaviour. Here, the limited data we have suggest that storm water pulses provide a major pathway for debris from the land to the sea, with  $81 \text{ g m}^{-3}$  of plastic debris during high-flow events in the USA. Methods to monitor the abundance of anthropogenic debris (including plastics) often vary considerably between countries and organizations, adding to difficulties in interpreting trends. As a consequence, the United Nations Environment Programme and the OSPAR Commission are currently taking steps to introduce standardized protocols. More recently, abundance at the sea surface in some regions and on some shorelines appears to be stabilizing, while in other areas such as the Pacific Gyre there are reports of considerable increases. On shorelines the quantities of debris, predominantly plastic, are greater in the Northern than in the Southern Hemisphere. The abundance of debris is greater adjacent to urban centres and on more frequented beaches and there is evidence that plastics are accumulating and becoming buried in sediments consider that contamination of remote habitats, such as the deep sea and the polar regions, is likely to increase as debris is carried there from more densely populated areas. Allowing for variability between habitats and locations, it seems inevitable, however, that the quantity of debris in the environment as a whole will continue to increase—unless we all change our practices. Even with such changes, plastic debris that is already in the environment will persist for a considerable time to come.

#### **5.4 Production, usage, waste management solutions**

Accumulation of plastic debris in the environment and the associated consequences are largely avoidable. Considerable immediate reductions in the quantity of waste entering natural environments, as opposed to landfill, could be achieved by better waste disposal and

material handling. Littering is a behavioural issue and some have suggested that it has increased in parallel with our use of disposable products and packaging. Perhaps increasing the capacity to recycle will help to reverse this trend such that we start to regard end-of-life materials as valuable feedstocks for new production rather than waste. To achieve this will require better education, engagement, enforcement and recycling capacity (cc the figure 1a–f(<http://www.swedishepa.se/upload>)). There is evidence that appropriate education can influence behaviour. For example, pre-production plastic pellets account for around 10 per cent, by number, of the plastic debris recorded on shorelines in Hawaii and substantial quantities have been recorded on shorelines in New Zealand. These pellets have entered the environment through spillage during transportation, handling and as cargo lost from ships. In the USA guidelines (cc figure 1e(<http://www.swedishepa.se/upload>)) on handling of resin pellets are reported to have reduced spillage during trials. Conservation organizations such as the UK Marine Conservation Society play an important role in education, and the annual beach cleans they organize can be a good way to raise public awareness and to collect data on trends in the abundance of debris on shorelines. However, there is a pressing need for education to reduce littering at source (figure 1d and e(<http://www.swedishepa.se/upload>)). This is especially important in urban settings where increased consumption of on-the-go/fast food coupled, in some locations, with a reduction in the availability of bins as a consequence of concerns about terrorism is likely to result in increased littering. Where plastic debris enters watercourses as a consequence of dumping or littering a range of strategies including catch basin inserts, booms and separators can be used to facilitate removal (figure 1f(<http://www.swedishepa.se/upload>)).



Figure 1. The pictorial illustrations of Solutions.

The pictorial illustrations of Solutions include: (figure a) measures to reduce the production of new plastics from oil, here an example showing how small changes in product packing reduced the weight of packaging required by 70%, while (figure b) re-useable plastic packing crates have reduced the packaging consumption of the same retailer by an estimated 30,000 tonnes per annum; and (figure c) recycling; here, bales of used plastic bottles have been sorted prior to recycling into new items, such as plastic packaging or textiles. Measures to reduce the quantity of plastic debris in the natural environment include: (figure d) educational signage to reduce contamination via storm drains and (figure e) via industrial spillage, together with (figure f) booms to intercept and facilitate the removal of riverine debris.

Substantial quantities of end-of-life plastics are disposed of to landfill. Waste generation statistics vary among countries and according to the rationale for data collection. For instance, plastics are a small component of waste by weight but a large component by volume. Temporal and spatial comparisons can thus be confounded, and data on quantities of waste recycled can be skewed according to categorization of various wastes. However, in many locations space in landfill is running out. It has also been suggested that because of the longevity of plastics, disposal to landfill may simply be storing problems for the future, considering an example, plasticizers and other additive chemicals have been shown to leach from landfills. The extent of this varies according to conditions, particularly pH and organic

content. There is evidence, however, that landfills can present a significant source of contaminants, such as BPA, to aquatic environments. Efficient treatment approaches are available and are in use in some countries.

From a waste management perspective, the three R's—Reduce, Reuse and Recycle are widely advocated to reduce the quantities of plastic and especially plastics packaging the waste we generate . outline the benefits and limitations of these strategies. They show that to be effective we need to consider the three R's in combination with each other and together with a fourth 'R', energy recovery. Indeed, we also need to consider a 5th 'R', molecular redesign, as an emerging and potentially very important strategy. Hence, the three R's become five: 'reduce, reuse, recycle, recover and redesign'. There are opportunities to 'reduce' usage of raw material by down gauging and there are also some opportunities to 'reuse' plastics, for example, in the transport of goods on an industrial (pallets, crates; and a domestic (carrier bags) scale. However, there is limited potential for wide-scale reuse of retail packaging because of the substantial back-haul distances and logistics involved in returning empty cartons to suppliers. Some of the energy content of plastics can be 'recovered' by incineration, and through approaches such as co-fuelling of kilns, reasonable energy efficiency can be achieved. These approaches have benefits compared with disposal to landfill since some of the energy content of plastics is recovered. However, energy recovery does not reduce the demand for raw material used in plastic production, hence it is considered less energy efficient than product recovery via recycling. In addition, concerns about emissions from incinerators can reduce the appeal of this waste disposal option. There is now strong evidence to indicate significant potential lies in increasing our ability to effectively recycle end-of-life plastic products. Although thermoplastics have been recycled since the 1970s, the proportion of material recycled has increased substantially in recent years and represents one of the most dynamic areas of the plastic industry today.

The recycling message is simple; both industry and society need to regard end-of-life items, including plastics, as raw materials rather than waste. At present our consumption of fossil fuels for plastic production is linear, from oil to waste via plastics. It is essential to

take a more cyclical approach to material usage, but achieving this goal is complex. Greatest energy efficiency is achieved where recycling diverts the need for use of fossil fuels as raw materials, good examples being the recycling of old polyethylene terephthalate (PET) bottles into new ones (closed-loop recycling) or where low-density polyethylene bottles are converted into waste bins (semi-closed loop). In addition to benefits as a consequence of more sustainable material usage, a recent life cycle analysis calculated that use of 100 per cent recycled PET rather than virgin PET to produce plastic bottles could give a 27 per cent reduction on CO<sub>2</sub> emissions.

There is also an increasing urgency to also design products, especially packaging, in order to achieve material reduction and greater end-of-life recyclability. Public support for recycling is high in some countries for example 57% in the UK and 80% in Australia, and consumers are keen to recycle, but the small size and the diversity of different symbols to describe a product's potential recyclability, together with uncertainties as to whether a product will actually be recycled if it is offered for collection, can hinder engagement. In our opinion, what is needed is a simplification and streamlining of everyday packaging, to facilitate recyclability, together with clearer labelling to inform users. One option could be a traffic light system so that consumers can easily distinguish from printed product labelling between packages that use recycled content and have high end-of-life recyclability (marked with a green spot), those that have low end-of-life recyclability and are predominantly made of virgin polymer (red spot), and those which lie between these extremes (amber spot). With combined actions including waste reduction, design for end-of-life, better labelling for consumers, increased options for on-the-go disposal to recycling and improved recycling capability, consider it could be possible to divert the majority of plastic from landfill over the next few decades. This will require consistency of policy measures and facilities among regions and will also require the cooperation of industry since ultimately there needs to be an acceptance of reduced usage and hence reduced income associated with the production of plastics from virgin polymer.

Molecular redesign of plastics (the 5th R) has become an emerging issue in green chemistry that should be incorporated within the design and life cycle analysis of plastics. In this context, green chemists aspire to design chemical products that are fully effective, yet have little or no toxicity or endocrine-disrupting activity; that break down into innocuous substances if released into the environment after use; and/or that are based upon renewable feedstocks, such as agricultural wastes. One of the fundamental factors limiting progress on all other R's is that the design criteria used to develop new monomers have rarely included specifications to enhance reusability, recyclability or recovery of plastic once it has been used. Typically, such assessments have only been made after a product entered the marketplace and problems involving waste and/or adverse health effects have begun to appear. Had the guiding principles of Green Chemistry been available to inform the syntheses of polymers over the past century, perhaps some of the environmental and health concerns described in this Theme Issue would be more manageable. To date, the application of these design criteria to polymers has remained largely in the laboratory. Polylactic acid, a biodegradable polymer sourced from corn and potatoes, has entered the marketplace and has the potential to make a valuable contribution among other strategies for waste management. However, life cycle analyses are required to help establish the most appropriate usage, disposal.

### **5.5 Biopolymers, degradable and non-degradable biopolymers solutions**

Degradable polymers have been advocated as an alternative to conventional oil-based plastics and their production has increased considerably in recent decades. Materials with functionality comparable to conventional plastics can now be produced on an industrial scale; they are more expensive than conventional polymers and account for less than 1 per cent of plastics production. Biopolymers differ from conventional polymers in that their feedstock is from renewable biomass rather than being oil-based. They may be natural polymers, or synthetic polymers made from biomass monomers or synthetic polymers made from synthetic monomers derived from biomass. They are often described as renewable

polymers since the original biomass, for example corn grown in agriculture, can be reproduced. The net carbon dioxide emission may be less than that with conventional polymers, but it is not zero since farming and pesticide production have carbon dioxide outputs. In addition, as a consequence of our rapidly increasing human population, it seems unlikely that there will be sufficient land to grow crops for food, let alone for substantial quantities of packaging in which to wrap it. One solution is to recycle waste food into biopolymers; this has merit, but will ultimately be limited by the amount of waste food available.

Biopolymers that are designed to breakdown in an industrial composter are described as 'biodegradables' while those that are intended to degrade in a domestic composter are known as 'compostable'. There are benefits of these biodegradable materials in specific applications, for example, with packaging of highly perishable goods where, regrettably, it can be necessary to dispose of perished unopened and unused product together with its wrapper. show experimentally that degradation of biodegradable, as opposed to compostable, polymers can be very slow in-home composters. Degradation of these polymers in landfills is also likely to be slow and may create unwanted methane emissions. Hence, the benefits of biopolymers are only realized if they are disposed of to an appropriate waste management system that uses their biodegradable features. Typically, this is achieved via industrial composting at 50°C for around 12 weeks to produce compost as a useful product.

There is also a popular misconception that degradable and biodegradable polymers offer solutions to the problems of plastic debris and the associated environmental hazards that result from littering. However, most of these materials are unlikely to degrade quickly in natural habitats, and there is concern that degradable, oil-based polymers could merely disintegrate into small pieces that are not in themselves any more degradable than conventional plastic. So, while biodegradable polymers offer some waste management solutions, there are limitations and considerable misunderstanding among the general public about their application. To gain the maximum benefit from degradable, biodegradable and

compostable materials, it is, therefore, essential to identify specific uses that offer clear advantages and to refine national and international standards and associated product labelling to indicate appropriate usage and appropriate disposal.

### 5.6 Policy measures

Our intention when preparing this Theme Issue was to focus on the science surrounding all aspects pertinent to plastics, the environment and human health. There are some omissions from the volume, such as input from social scientists on how best to convey relevant information to influence littering behaviour, consumer choice and engagement with recycling. This is in part the role of a Theme Issue such as this, and the final invited contribution to the volume examines the science–policy interface with particular reference to policy relating to plastics. This is a diverse subject area that will require a range of policies to focus at specific issues, including polymer safety, material reduction, reuse, recycling, biopolymers, biodegradable and compostable polymers, littering, dumping and industrial spillage.

This table Synthesis of current knowledge, uncertainty and recommended actions relevant to environmental and human health concerns arising from current production, use and disposal of plastics.

Table 5.1- uncertainty and recommended actions relevant to environmental and human health

	Established knowledge	concerns and uncertainty	recommendations for industry, research and policy
production and use	Plastics are inexpensive lightweight, versatile, water resistant and durable annual growth in plastic production	is our usage of hydrocarbons for plastics sustainable? to what extent could biopolymers replace oil-based	increase/incentivize material reduction and reuse construct life cycle analysis of production, disposal/recycling of major polymers (including biopolymers,



	<p>is approximately 9% (currently &gt;260 Mt yr<sup>-1</sup>) around 8% of world oil production is used to make plastics</p> <p>plastics bring extensive societal, human health and environmental benefits</p> <p>&gt;33% of production is used for disposable items of packaging</p>	<p>plastics?</p> <p>is there sufficient arable land for production of biomass (crops) required for biopolymers?</p> <p>to what extent does use of plastic powders as cleaning abrasives, and scrubbers results in direct release of particles to environment?</p>	<p>degradable and biodegradable polymers) and plastic products</p> <p>develop alternative monomers, polymers and additives using green chemistry approaches</p> <p>revise international standards for and introduce accurate/informative labelling of recyclable, 'degradable', 'biodegradable' and compostable polymers</p>
disposal: waste management	<p>plastics are a substantial part of domestic and industrial wastes in landfill</p> <p>recycling of some polymers (e.g. PET) has increased considerably in recent years, but substantial quantities of plastic waste not compatible with recycling</p> <p>biodegradable polymers typically require industrial composting and will not readily degrade in landfill</p> <p>biodegradable plastics can</p>	<p>are current disposal strategies sustainable—lack of space in landfill?</p> <p>to what extent do chemicals leach from plastic in landfill?</p> <p>little is known about the degradability or environmental fate of additives used in biodegradable polymers</p>	<p>increase/incentivize product design towards use of recycled feedstock and increased end-of-life recyclability</p> <p>improve methods to collect and separate plastic waste for recycling</p> <p>investment in/incentivize recycling operations</p> <p>standardize labelling so consumers can identify products with high end-of-life recyclability (traffic light system)</p> <p>research and monitoring of leachates from landfills</p>

	compromise recycling		
disposal: littering and dumping	<p>plastic debris is common in marine habitats worldwide, including poles and deep sea the abundance of plastic debris is increasing/stabilizing (not declining)</p> <p>plastic debris is fragmenting, with pieces &lt;20 µm on shorelines and in water column</p>	<p>to what extent will breakdown of plastic debris increase the abundance of small fragments in the environment?</p> <p>rates of accumulation of debris on land, in freshwaters and in the deep sea are not certain</p> <p>do biodegradable or compostable plastics degrade in natural habitats?</p>	<p>education/incentives to promote the value of end-of-life plastics as a feedstock for recycling</p> <p>education and associated enforcement on the wasteful and adverse ecological effects of plastic spillage, dumping and littering</p> <p>develop standard protocols and monitoring to evaluate trends in the abundance of plastic debris across in natural habitats</p> <p>cleaning programmes in natural, urban and industrial locations</p> <p>research on breakdown of degradable and biodegradables</p>
issues relating to wildlife	<p>&gt;260 species are known to ingest or become entangled in plastic debris</p> <p>ingestion is widespread in some populations (&gt;95% of individuals) and can compromise feeding</p> <p>entanglement in plastic debris can lead to severe injury and death</p>	<p>does ingestion of, or entanglement in, plastic debris have effects at the population level or can such effects combine with other stressors to do so?</p> <p>to what extent do plastics transport/release chemicals to wildlife?</p> <p>what are the consequences of the accumulation</p>	<p>research to establish the distribution, abundance and environmental consequences of micro- and nano-plastic fragments</p> <p>research to establish potential for plastics to transport chemicals to food chain</p> <p>research to establish population-level consequences of ingestion and entanglement</p> <p>education, monitoring and cleaning (see above)</p>

		of small plastic particles (e.g. abrasives from cleaning applications) in the environment?	
issues relating to human health	some plastics contain potentially harmful monomers and additive chemicals, including flame retardants and plasticizers adverse effects of additives evident in laboratory animals measurable levels of chemicals used as additives/monomers are present in the human population Canadian government declared BPA a toxic substance. USA National Toxicology Program expressed concern for adverse health effects	what are the effects of low-dose chronic exposure to chemicals or mixtures of chemicals used as plastic monomers or additives? dose-response curves may not be monotonic and so should not be extrapolated in risk assessment	conduct cumulative risk assessment/management of plastic additives and monomers biomonitoring of body burdens of additives/monomers effects on susceptible subpopulations (babies, children) and on those with high-exposure risks evaluate effects of exposure to mixtures of additives/monomers design/validate appropriate species/protocols to assess chronic low dose exposures to additives/monomers by humans

**Conclusion to part 5**

In conclusion, plastics offer considerable benefits for the future, but it is evident that our current approaches to production, use and disposal are not sustainable and present concerns for wildlife and human health. We have considerable knowledge about many of the environmental hazards, and information on human health effects is growing, but many concerns and uncertainties remain. There are solutions, but these can only be achieved by combined actions. There is a role for individuals, via appropriate use and disposal, particularly recycling; for industry by adopting green chemistry, material reduction and by designing products for reuse and/or end-of-life recyclability and for governments and policymakers by setting standards and targets, by defining appropriate product labelling to inform and incentivize change and by funding relevant academic research and technological developments. These measures must be considered within a framework of lifecycle analysis and this should incorporate all of the key stages in plastic production, including synthesis of the chemicals that are used in production, together with usage and disposal. In my opinion, these actions are overdue and are now required with urgent effect; there are diverse environmental hazards associated with the accumulation of plastic waste and there are growing concerns about effects on human health, yet plastic production continues to grow at approximately 9 per cent per annum. As a consequence, the quantity of plastics produced in the first 10 years of the current century will approach the total that was produced in the entire century that preceded.

## **GENERAL CONCLUSION**

Considering all the information in my diploma work, in which I considered the design of a smart storage bin, all of us are already familiar with the concept of "smart home". Now the concept of smart & connected technologies makes flights easier, faster and of course, cheaper.

Firstly I did research on the general requirements about having a storage bin on a passenger aircraft, where i also analyzed the current trends of the bins and the enhancements done to improve retention of the goods,

Secondly I worked on the variants of the prototype picked to implement the smart storage being in, seeing as Boeing was the pioneer designer of overhead storage bin, I

analyzed the long range Boeing aircraft with capability of conveying over 200plus passengers, in this area I calculated for the wings and fuselage layout and also calculated the center of gravity, after designing the plane I worked on the Smart storage bin prototype for the aircraft hereby analyzing the method of operation for the smart storage bin and also the system of its functionality, when I got done with the smart bin I looked into the labor protection for the designer and his production team, analyzing the working conditions and the danger factor analysis, in this section I listed the safety requirements to be observed when designing and producing the aircraft equipment to a better and more suitable working environment, I also looked into the environmental protection where I worked on the utilization of plastic to ensure a better working environment and living climate

## REFERENCES

1. <https://patentimages.storage.googleapis.com>
2. <https://patentimages.storage.googleapis.com/3>
3. <https://patentimages.storage.googleapis.com/4>
4. [ntimages.storage.googleapis.com/5](https://patentimages.storage.googleapis.com/5)
5. <https://www.freepatentsonline.com/9745064.html>
6. Aircraft Design: Lecture course / M.V. Karuskevich, T.P. Maslak, - K.: NAU, 2013-176 p.
7. Zhitomirskiy G.I. Aircraft design: A textbook for students of aviation specialties of universities. -M.: Mashinostroenie, 1991.

8. The design and durability of aircraft: Textbook / Zh.S. Chernenko, N.G. Sabitov, V.V. Garage and others - K.: KIIGA, 1985.
9. Aviation fundamentals: A. galstyan, L. Zhuravlova - K.: NAU, 2011. - 81p.
10. Sensor arrangement using units patentsonline, 2016
11. Aircraft design: A textbook for universities / edited by Egera S.M.-M.: Mashinostroenie, 1983
12. <https://blog.reduceyourworkerscomp.com/2011/04/14-steps-to-manufacturing-facility-safety/>
13. <https://www.atlantictraining.com/safety-tips/workplace-safety-tips.php>
14. <https://www.ccohs.ca/oshanswers/hsprograms/planning.html>
15. <https://www.ncbi.nlm.nih.gov/pmc/articles/PMC2873021/>
16. [https://en.wikipedia.org/wiki/Plastic\\_recycling](https://en.wikipedia.org/wiki/Plastic_recycling)
17. <http://www.swedishepa.se/Guidance/Grants/sustainable-plastic-use/>
18. [http://www.boeing.com/commercial/aeromagazine/aero\\_15/images/overhead\\_fig6.jpg](http://www.boeing.com/commercial/aeromagazine/aero_15/images/overhead_fig6.jpg)
19. [http://www.boeing.com/commercial/aeromagazine/aero\\_15/images/overhead\\_fig5.jpg](http://www.boeing.com/commercial/aeromagazine/aero_15/images/overhead_fig5.jpg)
20. [http://www.boeing.com/commercial/aeromagazine/aero\\_15/overhead\\_fig4c.html](http://www.boeing.com/commercial/aeromagazine/aero_15/overhead_fig4c.html)
21. [https://en.wikipedia.org/w/index.php?title=Boeing\\_767&action=edit&section=12](https://en.wikipedia.org/w/index.php?title=Boeing_767&action=edit&section=12)