

МІНІСТЕРСТВО ОСВІТИ І НАУКИ УКРАЇНИ
НАЦІОНАЛЬНИЙ АВІАЦІЙНИЙ УНІВЕРСИТЕТ
КАФЕДРА КОНСТРУКЦІЇ ЛІТАЛЬНИХ АПАРАТІВ

ДОПУСТИТИ ДО ЗАХИСТУ

Завідувач кафедри

д.т.н, професор

_____ С.Р. Ігнатович

«__» _____ 2021р.

ДИПЛОМНА РОБОТА

ВИПУСКНИКА ОСВІТНЬОГО СТУПЕНЯ МАГІСТРА

ЗІ СПЕЦІАЛЬНОСТІ

«АВІАЦІЙНА ТА РАКЕТНО-КОСМІЧНА ТЕХНІКА»

Тема: «Дослідження властивостей міцності скла методом склерометрії»

Виконавець: _____ **А.О. Атрошенкова**

Керівник: к.т.н., доцент _____ **В.І. Закієв**

Охорона праці: к.біол.н., доцент _____ **В.В. Коваленко**

Охорона навколишнього середовища:

д.т.н., доцент _____ **Т.В. Дудар**

Нормоконтролер: к.т.н., доцент _____ **С.В. Хижняк**

Київ 2021

MINISTRY OF EDUCATION AND SCIENCE OF UKRAINE
NATIONAL AVIATION UNIVERSITY
DEPARTMENT OF AIRCRAFT DESIGN

APPROVED BY

Head of department

Professor, Dr. of Sc.

_____S.R. Ignatovich

«___»_____2021.

MASTER THESIS

ON SPECIALITY

”AVIATION AND SPACE ROCKET TECHNOLOGY”

Theme: «Strength properties investigation of glass by scratch test method»

Prepared by: _____ **A.A. Atroshenkova**

Supervisor: PhD, associate professor _____ **V.I. Zakiev**

Labor protection:
Ph.d., associate professor _____ **V.V. Kovalenko**

Environmental protection:
Dr.Sc., professor _____ **T.V. Dudar**

Examined:
Ph.d., associate professor _____ **S.V. Khiznyak**

Kyiv 2021

НАЦІОНАЛЬНИЙ АВІАЦІЙНИЙ УНІВЕРСИТЕТ

Факультет аерокосмічний
Кафедра конструкції літальних апаратів
Освітній ступінь «Магістр»
Спеціальність 134 «Авіаційна та ракетно-космічна техніка»
Спеціалізації «Обладнання повітряних суден»

ЗАТВЕРДЖУЮ
Завідувач кафедри
д-р техн. наук, проф.
_____ С.Р. Ігнатович
«___» _____ 2021 р.

ЗАВДАННЯ

на виконання дипломної роботи студента
АТРОШЕНКОВОЇ АНАСТАСІЇ ОЛЕКСАНДРІВНИ

1. Тема роботи «Дослідження властивостей міцності скла методом склерометрії», затверджена наказом ректора від 8 жовтня 2021 року № 2173/ст.
2. Термін виконання проекту: з 11.10.2021р. по 31.12.2021 р.
3. Вихідні дані до проекту: зразки скла.
4. Зміст пояснювальної записки: аналіз скла як конструкційного матеріалу та його використання в аерокосмічній галузі, аналіз механічних властивостей скла та методів їх дослідження, дослідження міцності та стійкості до дряпання скляних зразків методом склометрії.
5. Перелік обов'язкового графічного (ілюстративного) матеріалу: приклади використання скла в авіаційній галузі, результати досліджень, авіаційне обладнання та вузли, де використовується скло як конструкційний матеріал, принципові схеми методів виміру механічних характеристик та загальний вигляд обладнання, на якому проводилися виміри.

6. Календарний план-графік

№	Завдання	Термін виконання	Відмітка про виконання
1	Огляд літератури за проблематикою роботи. Аналіз скла як конструкційного матеріалу.	11.10.2021–13.10.2021	
2	Проведення аналізу стійкості скла та методів її досліджень.	14.10.2021–22.10.2021	
3	Розробка методології для тесту склерометрії.	23.10.2021–30.10.2021	
4	Дослідження механічних характеристик скляних зразків	1.11.2021–19.11.2021	
5	Виконання частин, присвячених охороні навколишнього середовища та охорони праці.	20.11.2021–16.12.2021	
6	Підготовка ілюстративного матеріалу, написання пояснювальної записки.	17.12.2021–19.12.2021	
7	Перевірка, редагування та виправлення пояснювальної записки.	20.12.2021–22.12.2021	

7. Консультанти з окремих розділів

Розділ	Консультанти	Дата, підпис	
		Завдання видав	Завдання прийняв
Охорона праці	к.біол.н., доцент В.В. Коваленко		
Охорона навколишнього середовища	д.т.н., доцент Т.В. Дудар		

8. Дата видачі завдання: 8 жовтня 2021 року

Керівник дипломної роботи _____ В.І. Закієв

Завдання прийняв до виконання _____ А.О. Атрошенкова

NATIONAL AVIATION UNIVERSITY

Faculty aerospace
Department of aircraft design
Specialty 134 «Aviation and space rocket technology»
Educational professional program «Aircraft equipment»

APPROVED BY

Head of department

D. Sc., professor

_____ S.R. Ignatovych

«___» _____ 2021p.

TASK

For the master thesis

ANASTASIIA ATROSHENKOVA

1. Topic: «Strength properties investigation of glass by scratch test method», approved by the Rector's order № 2173/CT from 8 October 2021 year.
2. Period of work execution: 11.10.2021 year to 31.12.2021 year.
3. Initial data: glass samples.
4. Content (list of topics to be developed): analysis of glass as a structural material and its use in the aerospace industry, analysis of mechanical properties of glass and methods of their study, study of strength and resistance to scratching of glass samples by glassmetry.
5. Required material: examples of the use of glass in the aviation industry, research results, aviation equipment and units where glass is used as a structural material, schematic diagrams of methods for measuring mechanical properties and the general appearance of the equipment on which measurements were made.

6. Thesis schedule:

№	Task	Execution period	Done
1	Review of the literature on the issues of work. Analysis of glass as a structural material.	11.10.2021–13.10.2021	
2	Carrying out the analysis of stability of glass and research methods	14.10.2021–20.10.2021	
3	Development of methodology for scratch test method.	21.10.2021–30.10.2021	
4	Investigation of mechanical characteristics of glass samples	1.11.2021–19.11.2021	
5	Execution of the parts, devoted to environmental and labor protection.	20.11.2021–16.12.2021	
6	Preparation of illustrative material, writing the report.	17.12.2021–19.12.2021	
7	Explanatory note checking, editing and correction.	20.12.2021–22.12.2021	

7. Special chapter advisers

Chapter	Consultants	Date, signature	
		Task Issued	Task Received
Labor protection	Ph.d., associate professor V.V. Kovalenko		
Environmental protection	Dr.Sc., professor T.V. Dudar		

8. Date of issue of the task: 8 October 2021 year

Supervisor _____ V.I. Zakiev

Student _____ A.A. Atroshenkova

РЕФЕРАТ

Пояснювальна записка дипломної роботи магістра «Дослідження властивостей міцності скла методом склерометрії»:

81 с., 18 рис., 5 табл., 16 джерел

Об'єкт дослідження – механічні властивості скла.

Предмет дослідження – вимірювання міцнісних властивостей методіки склометрії.

Мета магістерської роботи – порівняльне дослідження міцності скла за допомогою методіки скретч-тесту.

Методи досліджень і розробок – випробування на скретч для дослідження властивостей міцності.

Новизна результатів – запропонована нова методика визначення міцнісних властивостей скла за допомогою тесту на дряпання.

Практична цінність – запропоновано метод оцінки механічних характеристик скла методом склометрії.

ЛІТАКИ, КОМПОЗИТНІ МАТЕРІАЛИ, СКЛО, ВИПРОБУВАННЯ НА ДРЯПИН, МЕХАНІЧНІ ВЛАСТИВОСТІ, МАГІСТЕРСЬКА ТЕХНІКА, МЕТОДИ ВИПРОБУВАННЯ, ДОСЛІДЖЕННЯ.

ABSTRACT

Master degree thesis “Strength properties investigation of glass by scratch test method”

P 81., 18 fig., 5 table, 16 references

Object of study – mechanical properties of glasses.

Subject of study – the scratch test technique strength properties measurement.

Aim of master thesis – comparative study of glass strength using scratch test technique.

Research and development methods – scratch test for strength properties investigation.

Novelty of the results – proposed new methodology of glasses strength properties using scratch test.

Practical value – proposed a method for assessing the mechanical characteristics of glasses by sclerometry.

AIRCRAFT, COMPOSITE MATERIALS, GLASS, SCRATCH TEST, MECHANICAL PROPERTIES, MASTER THESIS, TESTING METHODS, INVESTIGATION.

CONTENTS

LIST OF ABBREVIATIONS	11
INTRODUCTION	12
PART 1 APPLICATION OF GLASS IN AVIATION	14
1.1 Glass as structural material.....	14
1.2 Requirements for glass as an aircraft material	16
1.3 Types of glass.....	17
1.4 Ceramics and Glass in the Aerospace Industry	24
1.5 Problems of glass	28
Conclusion to the part 1.....	31
PART 2 MECHANICAL CHARACTERISTICS OF THE GLASS	32
2.1. Strength of the glass	33
2.2 Hardness of the glass	35
2.3 Fragility of glass.....	37
2.4 Griffiths model.....	38
2.5 Young's modulus of glass	40
2.6 Fracture toughness of the glass	41
2.7 DCPD method	44
2.8 Crack Length Determination by Ultrasonic Methods	45
2.9. Method of surface scratching before edge chipping	Error! Bookmark not defined.
Conclusion to the part 2.....	46
PART 3 METHODOLOGY	48
3.1. Scratch test method	48
3.2 Nanoindentation	Error! Bookmark not defined.
3.3 Test instrument.....	50
3.4. Results of the test	54
Conclusion to the part 3.....	61
PART 4 LABOUR PROTECTION	62
4.1 Introduction.....	62
4.2 Analysis of working conditions	62

4.2.1 Harmful substances in the air of the work area	62
4.2.2. Heat effect	64
4.2.3 Production noise	66
4.2.4 Fire protection	68
Conclusion to part 4	69
PART 5 DIFFERENT SOURCES OF GLASS FOR AIRCRAFT INDUSTRY	71
5.1 Glass resources and how they effects on the environment	71
5.2 Improvement from the impact	74
Conclusion of the part 5	77
GENERAL CONCLUSION	79
References.....	80

LIST OF ABBREVIATIONS

SOP – Structural Optics Product
CFM - Classical Fracture Mechanics
ETF - Griffith's Energy Theory of Fracture
LFM - Linear Fracture Mechanics
KFT - Kinetic Fracture Theory
DAC - Digital-to-Analog Converter
ADC - Analog-to-Digital Converter
EF - Edge Flaking
LED - Light-Emitting Diode
DCPD - Direct Current Potential Drop
SEVNB - Single Edge V-Notched Beam

INTRODUCTION

Modern trends in aircraft construction run up against the tasks of ensuring the safety and environmental friendliness of flights. This aspect requires the search for new methods and approaches to the design of aircraft structures in order to develop optimal technical solutions. For air carriers, the highest priority issues are savings, namely increased fuel efficiency, as well as a significant increase in flight range. Aircraft companies are trying to keep up with the modern requirements of air carriers and are developing new aircraft models that consume less fuel than previous models. However, the possibilities for reducing aerodynamic drag within the framework of the traditional approach are practically exhausted, and the remaining potential for the development of turbofan engines is assessed as relatively small. To create an aircraft with good fuel efficiency, it is necessary to reduce take-off weight, improve aerodynamic quality and install engines with low fuel consumption.

A solution to reduce the takeoff weight of the order of 20-40% is the use of composite materials in modern airliners. Their use also improves the functional properties of aircraft, maintaining an optimal balance between strength and weight, increasing energy efficiency, and also minimizes operating costs. Thus, not only the absence of corrosion but also the possibility of creating load-bearing structural elements with specified strength properties brings composite materials to a new level.

To assess the increase in the number of composites as structural materials, consider an example of a Boeing line. So, in the manufacturing of Boeing 767 were used about 1.5 tons of composites, which included fiberglass fairings and steering surfaces. For the Boeing 777 the number increased to 10 tons, as composites became a part of the horizontal and vertical fins. The new Boeing 787 already consists of 35 tons, distributed throughout the airframe from the wings and fuselage to the tail and control surfaces.

Compared to aluminum alloys, composite materials such as carbon fiber have a higher specific strength, while fiberglass has higher tensile strength. For aircraft,

fiberglass is used in unloaded parts and in the nose cone. Fiberglass is heavier than carbon fiber and less durable, but significantly less expensive.

Like fiberglass, aircraft glazing has also gone under modernization due to its widespread use. Thanks to the development of materials science, the outdated concept of the fragility of glass products has radically changed towards transparent armor. In modern aircraft glazing, organic glass is the main material, occupying from 80 to 100% of the entire glazing area.

Investigation of the structure of glass, as well as the variability of changes in technological processes of glassmaking is an important object of study in order to further expand glass usage. Thus, the study of mechanical characteristics of the material, as well as various methods of testing is an important component of understanding their need in aviation.

PART 1

APPLICATION OF GLASS IN AVIATION

1.1 Glass as structural material

Today, glass is used as a structural material in almost all industries. At the moment, glass is widely used in the construction industry, in the optical industry, medicine, mechanical engineering, instrument making, interior design, modern architecture, electrical engineering and in everyday life. Fiberglass is a unique building material. Obtained by processing glass, glass fiber is impact-resistant, fire-resistant, environmentally friendly, it does not rot or deform, and also has high thermal insulation and sound-absorbing characteristics. Fiberglass is used to produce fiberglass, glass wool, reinforced and plastic fiberglass, glass fiber, glass fiber wallpaper, fiberglass mesh.

The glass contains quartz sand, limestone, dolomite, but other substances (aluminum and boron oxide) are added to improve its properties. This is how various types of glass are obtained - building, container, technical, and high-quality. In construction, sheet glass is used, which is patterned, tempered, heat-resistant, impact-resistant, reinforced.

In aviation glass as a structural material has also found its application (fig.1.1). Together with the metals used in the outer contour of the aircraft, it must provide the necessary strength characteristics of the product, while possessing high optical properties. As with any material, the determination of overall serviceability begins with a study of its physicochemical properties.

The study of composite materials, in particular, attracts attention by the possibility of changing the physical properties during their production. In the aerospace industry, glass and glass ceramics are valued for their high thermal stability compared to polymers and conventional aerospace alloys, high strength-to-weight ratio, corrosion resistance, and relatively low manufacturing costs. [1]

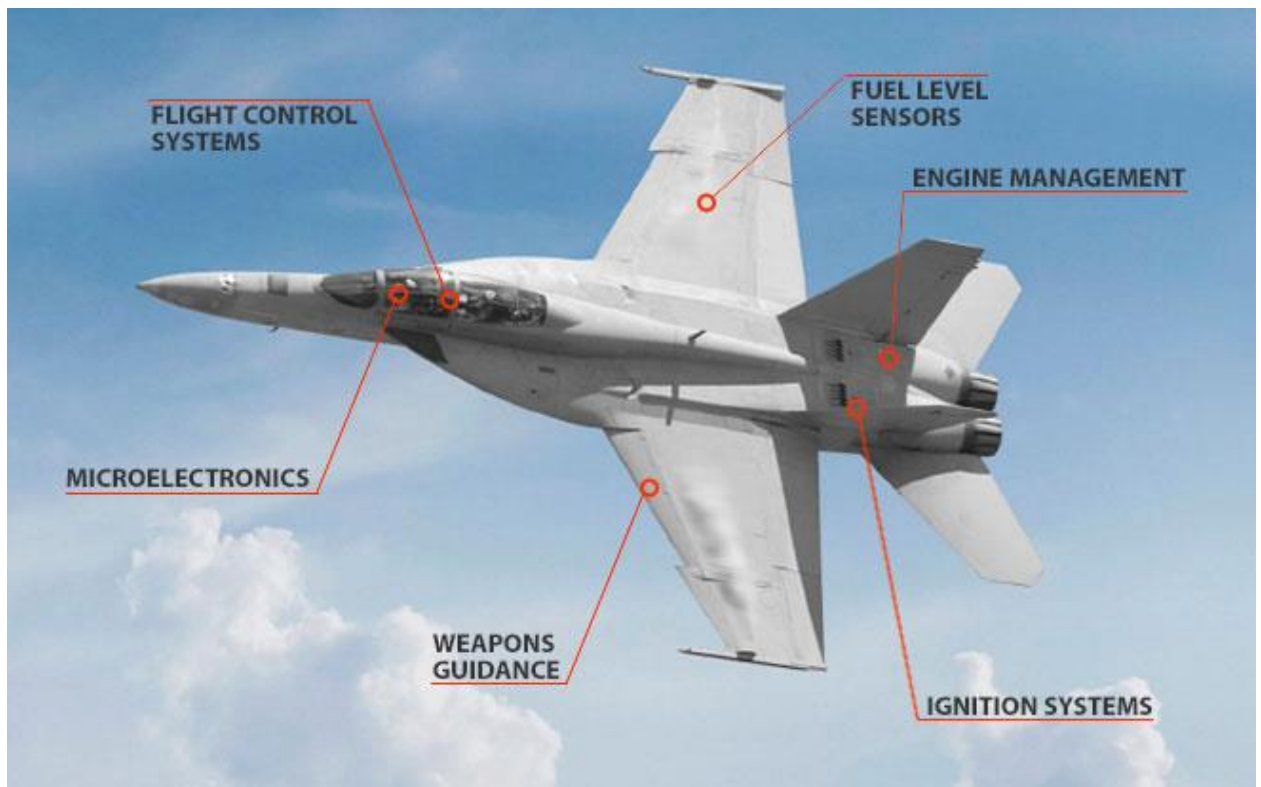

Figure 1.1 – Example of glass-made parts

Silicate glasses and ceramics have three main characteristics. They are characterized by:

- 1) covalent chemical bond;
- 2) nanostructural level;
- 3) streamlining the short-range structure.

Due to these characteristics, the demand for the use of glass and ceramics for parts and structures operating at high and ultra-high temperatures has increased. Also, thanks to the factors listed above, this material provides high chemical stability, hardness, resistance to corrosive and erosive effects.

Glass-based materials include various varieties of composite materials, namely: reinforced glass composites, borosilicate, high-silica and quartz glass, and ceramic-forming glasses. It is also worth noting fiberglass, a distinctive feature of which is reinforcement with continuous fibers. To date, the field of materials science has advanced the stage of development of glass-forming, ceramic, glass-ceramic and glass-crystalline matrices with carbon fibers, fabrics, needle crystals, silicon carbide and silicon dioxide fibers. The low temperature of the formation of the glass-ceramic

matrix in the composite material reduces the likelihood of loss of the oxidative strength of carbon fibers. Directional crystallization of the glass matrix or the so-called "ceramization" significantly increases the load.

In the aerospace industry, glass and glass ceramics are valued for their high thermal stability compared to polymers and conventional aerospace alloys, high strength-to-weight ratio, corrosion resistance, and relatively low manufacturing costs [1].

1.2 Requirements for glass as an aircraft material

It is the aviation and rocket industry that makes the greatest demands on the material, since it is the leading one for the development of technologies. It is the aircraft that cause the most difficult problems in solving design problems. From window coverings to engine parts and turbine blades; in the aerospace industry, some of the strongest, lightweight and heat-resistant materials in the world are used.

A structural optics product is a plate or shell consisting of one or more layers of materials transparent to electromagnetic radiation, which is a supporting element of the aircraft structure and provides the necessary optical parameters under specified conditions of external influences. This implies 2 groups of basic requirements for SOP:

- a) structural strength and resistance to external influences;
- b) optical performance and their preservation, under operating conditions.

The first group of requirements is achieved by creating a structure using sufficiently strong materials or their compositions (triplexes, multilayer blocks), by means of fastening and sealing, which provides an optimal loading scheme for its elements. The second group of requirements is satisfied by the use of materials with the required transparency in a given range, ensuring a given shape of a transparent element, and measures to preserve it under operating conditions.

In general, the most important requirements for SOP in the aircraft and helicopter cabins are:

1. SOP parts must withstand short-term and long-term static, as well as dynamic loads that meet the requirements for a particular aircraft, with high level of reliability.
2. Light transmittance should be within 60-85%, light scattering should not exceed 2.5%. Glazing should exclude unacceptable kinks of the horizon line, approach and removal, deformation and play of the image (violation of the proportions of parts of the objects under consideration), must not allow the harmful effects of radiation.
3. The glazing surface must be abrasion-resistant, that is, resistant to scratching and the effect of abrasive particles, which cause a decrease in transmission and an increase in light scattering, withstand rain erosion, hail.
4. The glazing must not fog up and freeze up, for which an electric heating element must be provided.
5. Operating temperatures, depending on the type of aircraft, can vary from minus 60 to +200 ° C and above.
6. The glazing should be as light as possible.

1.3 Types of glass

Raw materials, as the main component in the manufacture of glass, endow it with various properties and external shape. In industry, there are the following varieties:

1. Quartz
2. Sodium silicate
3. Lime
4. Lead
5. Borosilicate

Tempered Glass - Used primarily for center windshields due to its increased strength. During the manufacturing process, the temperature reaches up to 1250 ° F over the entire surface of the material, after which, the glass is rapidly cooled to room temperature. Due to this heat treatment of the material, internal tensile forces

arise, which act with a negative sign for the outer surface. Surface compression determines the strength of tempered glass and reaches approximately 36,000.p.s.i with a temperature coefficient of expansion of approximately 0.000003 per ° F.

The high demands of the aerospace industry cannot always be met by material selection. the technological and thermal process is far from creating an ideal structure. Durability, scratch resistance, no flammability, no exposure to temperature changes or sunlight, and colorlessness cannot all be balanced in a transparent material. From the point of view of manufacturing processes, the problem of homogeneity and the process of imparting a complex structural form arises. The high demand for volume and low cost push the economic aspect also to the level of importance of the decision. Windshields and cab covers have their own limited resource, because Over time, loss of discoloration can be observed, a significant increase in the number of scratches, which prevents good visibility, as well as deformation of the primary structure. Therefore, it is also necessary to provide for the possibility of replacement and ease of removal/installation of old material.

Pyralin is a nitrocellulose plastic material called pyroxylin, which is a solution of nitrocellulose in camphor. The nitrocellulose used is non-explosive and non-flammable, which is the main advantage of fluff cotton nitrocellulose. Pyroxylin is mixed with camphor and alcohol, heated and pressed into solid blocks, from which it is possible to cut a sheet of the required thickness. Depending on structural strength requirements, sheet thickness can range from 0.030 "to 0.150", however there are limitations on a full sheet of 21 "to 50". This thermoplastic material can be softened by heating and injection molded into double curvature molds such as those used on the tops of sliding cab hoods. It also lends itself to sawing and drilling, which is why it is often used in commercial aircraft.

Plastecele is a cellulose acetate plastic whose technology is adjacent to nitrocellulose plastic. The sizes and weights available are similar to the material above. The use in military aviation is characterized by the inherent fire resistance of this material. Thermoplasticity makes it possible to form the required configuration of the part by applying pressure and heating. Hot water at 150 ° F or air pressure at

50 psi can handle the softening task. The use of air also helps the material to cool and solidify. The main disadvantage, as with other transparent plastics, is the high compression-expansion differential between internal and external forces. Correct installation, providing mutual compensation for temperature changes, and will also significantly increase its service life.

Vynylite is a copolymer resin of vinyl chloride and vinyl acetate. It is non-combustible and has the general properties required for aircraft cabin enclosures and is available in a common range of commercial sizes.

Aviation SOP can be classified in various ways, for example by:

- destination: airplanes (Fig. 1.1), helicopters (Fig. 1.2), spacecraft (Fig. 1.3);
- optical accuracy: visual, instrumental; with indication of the instrument, takeoff and landing and visual zones;
- design type: lanterns, portholes, hoods;
- surface shape: flat, bent;
- in terms of resistance to mechanical stress: bird-resistant (all frontal glazing of lanterns), bullet-resistant;
- in the spectral range: operating in the visible (glazing of lanterns, optical windows) infrared part of the spectrum, in the combined range;
- type of composition: single-layer, multi-layer (glazing of lanterns), chamber / space / (space windows);
- the presence of anti-icing heating: heating (frontal and not always side glazing of the lanterns), unheated (vents, sometimes optical windows and the front part of the lantern);
- the type of transparent material: silicate, organic, heterogeneous, quartz, ceramic.

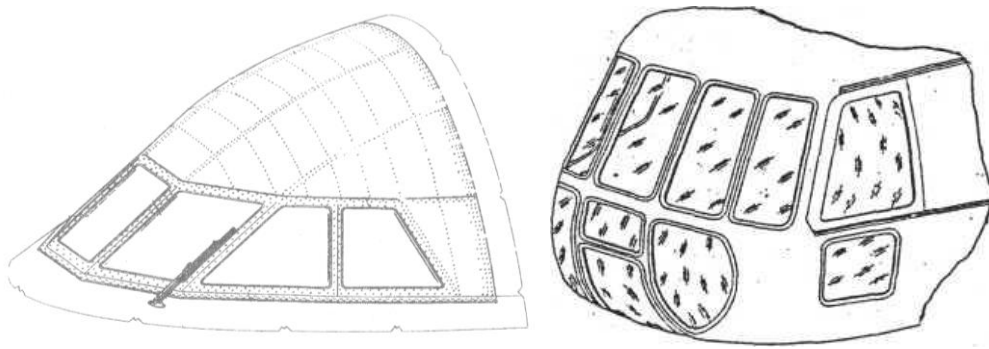

Figure 1.2 - Examples of helicopters' and aircrafts' SOP

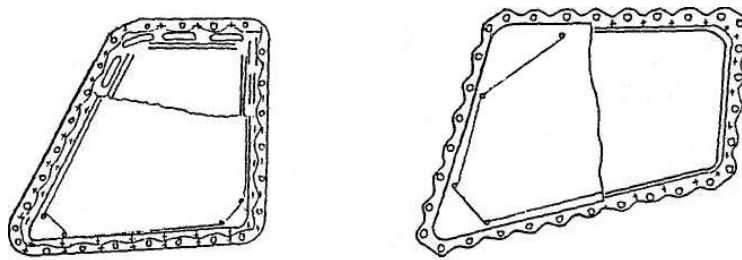

Figure 1.3 – Example of spacecrafts' SOP

The main material for the manufacture of aircraft SOP is thermally polished sheet silicate glass produced by surface molding on a tin melt (float process). The main component of silicate glass is silicon dioxide; it contains about 70-75% in the mixture. This substance is obtained from quartz sand, which is preliminarily cleaned of any contaminants and granulated. The second component of silicate glass is calcium oxide, which is responsible for shine and durability. In the manufacture of silicate glass, ordinary lime is used. And the third component of the glass mixture is alkali metal oxides. Potassium oxide or sodium oxide can be used. These elements make the mixture malleable to melting and further processing. The content of alkali metal oxides does not exceed 17%. In production, soda or potash is used, which decompose into oxides at high temperatures. The main components are crushed into a homogeneous mass or mixture. At the next stage, the composition enters the furnace, where, under the influence of high temperature, which reaches 2500 degrees, the mixture melts to a uniformly liquid amorphous mass. Next, the molten mixture is poured into molds that correspond to the type of the finished glass product. After that, the glass is allowed to harden and take the required shape.

Plexiglas (thermoplastics) - polymethyl methacrylates and polycarbonate - are used for glazing the lanterns of cabins and cabins of aircraft and helicopters. Compared to silicate glasses, organic glasses have a 2 times lower density and increased specific impact strength. The glasses are colorless, have a transmission limit in the UV region at 300-400 nm, the level of transmission in the visible region is 80-90%. Plexiglas, especially polycarbonate, are easily scratched, therefore they require special coatings or protected with silicate glass. Scratches and defects in optical non-heat resistance are eliminated by grinding and polishing the plexiglass as they occur under operating conditions.

PLEXIGLAS GS 241 – is a cast plexiglass that meets all aviation requirements. It is used for glazing lanterns of gliders, ultralight aircraft. Not used in military aviation. Available sheet thickness - 2-6 mm. The manufacturer produces aviation plexiglass of this brand in sheets of 2030x3050 mm.

PLEXIGLAS GS 245 – is an improved aviation plexiglass with enhanced protection against atmospheric factors and mechanical stress. Has a higher optical performance. It is used for glazing of helicopters, glider lights, protective glasses for landing lights, training and sports aircraft. The thickness of the sheet blank is 2-25 mm. The dimensions of the sheets are 2030x3050 mm.

PLEXIGLAS GS 249 – aviation plexiglass that meets the most stringent requirements in terms of strength, resistance to cracking, bending and tearing, dimensional stability when heated, moisture resistance, heat resistance. Suitable not only for private and commercial aviation, but also for glazing military equipment, including fighters. This grade is produced in sheets with a thickness of 2-85 mm. Sheets up to 30 mm are manufactured in standard sizes 2030x3050 mm. For thicknesses of 30-85 mm, other standard sizes of sheets are available: 1830x1830 mm, 1670x 1300 mm, 2400x1200 mm.

The most important material currently used as a transparent element of a spacecraft, heat-resistant glazing of aircraft, light and transparent hatches of onboard optical devices is quartz glass, which has high indicators of individual properties and their favorable combination. Being practically a single-component substance, quartz

glass can be obtained in various ways, avoiding the introduction of undesirable impurities. The raw material for quartz glass is natural quartz, rock crystal, artificially grown quartz crystals, synthetic silicon dioxide, volatile silicon compounds oxidized at high temperatures. At the same time, the strength of quartz glass is low (with a transverse bending of 50-70 MPa).

Unlike silicate glass obtained by the float process, which does not require additional optical processing, quartz glass used both for optical elements and for visual illuminators is mechanically processed after block surfacing. When exposed to an abrasive, the surface of the quartz glass is covered with a network of microcracks.

Colored glasses (light filters) are used for on-board signal, marker, aeronautical (navigational), code, pulse lights. Coloring is achieved by introducing dyes into silicate glass in the form of ions of copper, chromium, cobalt, sulfur, selenium, cadmium, zinc, etc. Properties of such type of glasses are shown in the table 1.1. In connection with the use of powerful pulsed light sources on board the aircraft, high requirements are imposed on colored glasses in terms of thermal resistance, which is ensured by the development of compositions with a reduced temperature coefficient of expansion.

Table 1.1 - Characteristics of the colored glasses

Glass brand	Color	Lighting characteristics		
		Transmission, %	Limiting color tone, nm	Color purity, %
TCK-6	red	23	617	99
KCO	red	18	610-700	95
TCM 500	red	16	610-700	95
TCM-501	orange	38	585-600	85
TCM-502	green	14	495-545	45
3C-112	green	18	495-563	48

For the manufacture of structural optics products that work as part of onboard aviation and space devices and systems in the infrared region of the spectrum, materials are required that have the required transmission level in a given spectral range, mechanical (structural) strength, and chemical resistance. For optical elements of infrared technology, glasses, polycrystalline materials (optical ceramics), and single crystals are used.

Aircraft and helicopter glazing is subject to increased shock and vibration loads, atmospheric influences, temperature and humidity changes. To ensure the reliability and safety of the aircraft, material is needed that surpasses analogues in physical, mechanical and operational characteristics. Aviation plexiglass differs from other brands of plexiglass and from ordinary glass in several ways. Thanks to the developed casting technology, it became possible to obtain increased strength, resistance to tearing and cracking. Additional molecular bonds make aviation plexiglass 11 times stronger than conventional glass. Special grades of aviation glass are more weather resistant. Glazing is not afraid of temperature extremes, precipitation, wind and snow loads, frost. Important features - such plexiglass does not fog up, does not freeze and has the property of self-cleaning. Aviation plexiglass is several times lighter than hardened glass. This simplifies the installation of glazing, reduces the overall weight of the aircraft and increases the maneuverability of the aircraft. It is also worth noting the increased light transmittance (91%), high transparency and improved optical characteristics. Glazing transmits a perfectly clear picture without distortion of color and shape, provides the visibility necessary for aviation conditions. Aviation plexiglass, unlike ordinary glass, lends itself to restoration. If defects appear on the surface of the glazing due to improper care, they can be removed by hand polishing. This extends the life of the glasses, eliminating the need to completely replace them. The material has the ability to block infrared radiation. Sunlight enters the cab, but does not heat up the space, which creates a comfortable microclimate and reduces air conditioning costs.

1.4 Ceramics and Glass in the Aerospace Industry

Since ceramics, as a structural material, is lighter than metal, this increases the speed of the aircraft, reduces fuel consumption, and increases the payload. In turn, this increases the resource of the aircraft during its operation. Thermal stability allows engines to run at higher temperatures, which reduces CO₂ and NO_x emissions. Also, due to this property, ceramics are often used in domes and fairings (often the bow), withstanding aerodynamic heating. Electrical isolation is necessary to prevent electromagnetic interference with the instruments and the communication system between the pilot and ground control. High energy ablation is used to protect spacecraft from particles and meteorites, and to protect military aircraft and helicopters during field tests and military missions. Corrosion resistance and chemical stability are essential to protect aircraft parts from contact with corrosive and hazardous materials such as jet fuel. This property gives a significant advantage over metals and prolongs the load cycle for critical parts. Wear resistance is necessary to resist frictional forces in parts such as brakes and bearings.

In airplanes, transparent materials are often used for windshields and general cabin glazing. Two main types prevail among the total number of materials - glass and various transparent plastics. Safety glass is used as a prerequisite for safe conditions. For windshields and bomber lanterns, high-quality laminated sheet glass is used, where the viewing angle is of the greatest importance. Laminated bulletproof glass has found its application in parts of the windshield directly in front of the pilot or other crew members. A cheaper type of material is used for relatively insignificant side windows and dormers. In some aircraft, where weight and/or cost are important, transparent plastics are used in bulk. Oftentimes, clear plastic is scratched, discolored and deformed much more than glass, and must be refurbished or replaced frequently.

Many types of glazing are available to the aircraft designer. The choice of glazing material depends on many factors, such as:

Optical properties. This qualification depends on many factors, including the type of aircraft (commercial, military), the specific purpose of the glazing material and the expected number of night flights, and much more.

Strength properties. These characteristics are dependent on aircraft speed, expected altitude, window or canopy size, landing conditions, etc.

Weathering characteristics. These design considerations are based on the duration of flights, the general environment in which the aircraft will operate, and the type of maintenance expected.

Heat resistance. This qualification is very important and depends on the general characteristics of the aircraft, speed, altitude and range.

In the aerospace industry it is used in engines, components of engine and exhaust systems, brakes, insulating tiles, nose cones and high-temperature coatings, windshields, panels and mirrors for cabin interiors, LED lighting.

In the aerospace industry it is used in engines, components of engine and exhaust systems, brakes, insulating tiles, nose cones and high-temperature coatings, windshields (Fig.1.4), panels (Fig. 1.5) and mirrors for cabin interiors, LED lighting.



Figure 1.4 – Example of the aircraft glass windshell



Figure 1.5 – Example of the glass cockpit

Ceramics are mainly used in engines and exhaust systems, heat shields, and structures for ultra-high-speed flying objects. Ceramics and ceramic matrix composites, which can withstand temperatures up to 1600°C , are used to produce lightweight turbine components that require less cooling air, such as blades, vanes, nozzles and combustion liners, and exhaust system parts that improve acoustic attenuation. and have a long service life due to their resistance to abrasion and corrosion.

Other ceramics applications in the aerospace industry include brakes, bearings, seals, and other wear-resistant components; armor for helicopters; electronic structures for thermal management; lightweight optical components (eg silicon carbide mirrors); radiators (i.e. cooling systems) of spacecraft; and windshield coverings [4].

Aircraft transparencies are characterized by location. A windshield or windscreen is a transparency in the forward section of the cockpit, and it provides the primary area of vision for the pilots. Windshields are usually a single piece or a left/right pair. Canopies are generally made of monolithic or laminated acrylics and polycarbonates, whereas windshields and windows will many times incorporate glass layers or even be made of all glass layers (mission dependent) [5].

There are also specially designed high optical properties called interlayers and include polyurethane and silicone. They can be used to connect the core, and are also used in cases where additional safety features are required, such as resistance to blows from birds, fail-safe under pressure, and anti-fog and anti-icing systems. In passenger airliners, the implementation of electrically adjustable windows is gaining popularity, while in military aviation the most pressing issue is the design of the canopy.

The F-16 has a polycarbonate-acrylic plastic hood (Figure 1.4.3). It consists of two to four layers of acrylic and / or polycarbonate core and one to three intermediate layers of polyurethane or silicone. The innermost layer is formed into a complex curvature, which is connected to the outer layers by means of intermediate layers of polyurethane or silicone.



Figure 1.6 – Polycarbonate-acrylic canopy

The F-22's canopy cover is by far the largest single piece of monolithic polycarbonate material. Due to the absence of the bow (frame) of the dome, the optical properties are evenly distributed over the entire surface of the product and presents all the required functions with a low level of observation in a winning light. Internal and external coatings are used to protect transparencies and the crew from various hazards during operation. Reducing solar heat, laser shielding and / or electromagnetic shielding can be observed with these coatings. These innovations

were due to the problems and requirements of night vision systems. On some aircraft, the protective coating is given a distinctive color. This tinting can serve several different functions depending on the aircraft on which it is used. For example, in the F-16 and F-22 aircraft, protective covers play the role of preventing radiation from threat radar systems from reflecting off the interior of the cockpit to help reduce the aircraft's radar cross-section.

Commercial aviation and regional jets typically take a layered approach similar to military aircraft, but tend to use more structural materials consisting of thermally tempered glass (such as Boeing 717 main windshields), lightweight combinations, glass acrylic panels, or an all-glass side cockpit ... windows (eg Boeing 747 series) or even several layers of stretched acrylic (eg new generation 737). The material of the intermediate layer (s) for these configurations is usually urethane. Airbus aircraft can also use vinyl backing in addition to urethane backing (eg Airbus A300). The regional jets Alena, Bombardier, Embraer, Merlin, SAAB, and others are similar in design. More common in commercial aircraft, where weight (which is closely related to fuel economy) may be more important, is the use of structural layers of windshield and windows, which can be part of the structural support of the airframe to help reduce the weight of the airframe. Damage to these windshields and windows can weaken the structural integrity of the aircraft.

1.5 Problems of glass

A significant decrease in safety margins when calculating aviation glass is associated with defects in the molten glass, which include various violations of physical and chemical homogeneity arising in the process of glass melting. Like shortcomings or violations of the technological mode of molding and subsequent processing of products, defects in water glass are dangerous, first of all, from the point of view of violation of the mechanical strength of glass due to the formation of local stress concentrators. Such defects are often not detected at the stage of manufacturing finished building products (double-glazed windows) and are detected

even at the stage of operation in the form of a sudden spontaneous violation of the integrity of the glass.

As noted above, in practice, there is no ideally homogeneous glass melt. Glass made in industrial furnaces is always characterized by varying degrees of inhomogeneity, one or another defect, and sometimes several. The reasons for the appearance of defects in molten glass during the melting process and their types are very diverse. In the special literature, there are three main types, classified according to the state of aggregation. These are mainly gas inclusions, glassy inclusions and crystalline inclusions.

For the glazing of aircraft that regularly raise a huge amount of dust into the air during takeoff and landing, abrasion resistance is important. Ordinary silicate glass has good performance in this sense, but it does not differ in particular impact resistance. A multi-layered composition will be stronger. However, if you use only silicate glass, you will have to come to terms with the fact that the plane or helicopter has gained weight. There is a way to lighten the composition - to use optical polycarbonate, the first samples of which appeared about 10 years ago.

Polycarbonate is an affordable material. In everyday life, it is used for the manufacture of country greenhouses. However, when it comes to aviation, customers impose additional requirements on it: resistance to various chemicals, ultraviolet and infrared spectrum, heat resistance, and so on. Initially, polycarbonate does not possess these qualities, but it can acquire due to the addition of various ingredients, which makes it possible to turn the usual polycarbonate into a monolithic optical polycarbonate.

There are also some problems during the processing of glass products. So, all work related to this material must be done before it is hardened, since after this process it will no longer be possible to do anything with it mechanically. Glass is a hard and brittle material at the same time. In this regard, when drilling holes, it is worth observing the following mandatory conditions:

1. Holes must be drilled on both sides.

2. Do not overheat the glass. Therefore, the drilling area must be constantly cooled with water. It will also wash away glass dust that remains after drilling, and eliminates its harmful effects.

3. Drilling must be carried out at high speeds and low pressure, with periodic retraction of the drill.

4. The glass should be on a flat and solid surface.

5. Displacement of the glass during drilling is not allowed.

6. The drill must be placed strictly perpendicular.

7. Micro cracks appear along the edges of the drilled hole. During subsequent hardening, they can lead to cracking. To eliminate this, the holes must be countersunk, and on both sides. This process is carried out using a special drill, on which there is diamond dusting.

Conclusion to the part 1

Glasses are widely used as a structural material. The requirements for their mechanical characteristics served as an impetus for the development of materials science and the creation of new materials based on them. A variety of types of glass allows you to select the required material for the parameters of any aircraft design. There are three main types of glass used in aviation: silicate, organic and polycarbonate. A number of fiberglass plastics - composite materials based on glass reinforcing fillers and polymer binders (matrices) - were developed.

In the production of loaded products from fiberglass for aviation technology, the most widespread is the autoclave processing technology with the use of semi-finished products (prepregs) - reinforcing fillers pre-impregnated with a binder. Glass materials can be used to make not only lightly loaded parts and parts for optical purposes, but also loaded units. In addition to the glazing itself of the frontal parts of the units, this material takes part in the structure of such systems as flight control systems, ignition systems, fuel level sensors, microelectronics, engine management, weapons guidance.

Their production is more environmentally friendly, but significantly more expensive. Modern glass manufacturing companies are trying to improve mechanical performance by various methods: updated casting methods, developing new protective coatings and improved molding methods. As with any material, glass has its drawbacks during production.

PART 2

MECHANICAL PROPERTIES OF THE GLASS

Aircraft glass is the most vulnerable part. Manufacturers are constantly improving the technology of its manufacture, paying special attention to safety. The frontal structure in the liner can crack from a collision with birds, from a sharp drop in temperature, pressure, which is constantly encountered in flight. Using the wrong or defective parts for installation can also lead to cracking. Even with a slight destruction, the glass becomes covered with a "web" of small cracks, which reduces its transparency and leads to an emergency.

The safety factors necessary for glass components are significantly higher than for other materials used in aircraft construction due to the loss of strength with duration of load, the variability in strength inherent in glass, and the thickness tolerances and high notch sensitivity. With an increase in speed, the requirements for the thermal stability of the glazing increased, with which organic glass could no longer cope. At the same time, the requirements for optics and visibility were tightened. Federal regulations in the United States require window panes to “withstand, without penetration, the impact of a four-pound bird when the plane's speed is approximately 340 knots” in the 737 case.

Several key requirements are imposed on modern glass, among which, in addition to high strength, are optical transparency, high light transmission, anti-reflective properties that increase the viewing range, protection from the effects of solar and other radiation, and anti-icing. properties that provide uniform electrical resistivity. All this is achieved through aerosol, vacuum or magnetron coating.

Initially, relatively lightly loaded aircraft structures were made of fiberglass: surface antennas, containers for flexible fuel tanks, onboard equipment, antenna radomes, electrical equipment panels, thermal insulation coatings. At present, such highly loaded structures are made from this material, such as high-pressure vessels

and cylinders, engine casings, propeller blade spars of helicopters and aircraft, air ducts and air intakes, large parts, fairings, etc.

Strength is one of the most important characteristics of all types of materials. Insufficient mechanical strength and the fragility of glass limits its widespread use as a structural and building material. The strength of glass depends on the condition of its surface, chemical composition, annealing quality, homogeneity, load duration, environment, temperature.

A number of important qualities also belong to the advantages of the material. Aviation Plexiglas is absolutely smooth and has good light transmittance. It is important that this characteristic is maintained in any weather during the entire period of use. Acrylic is a flexible enough material that allows you to create almost any shape in accordance with the design features. A special coating prevents dirt from sticking to organic glass, which saves significant cleaning costs. Windshields of any type of air transport are capable of withstanding fluctuations in a wide temperature range.

2.1. Strength of the glass

Strength is the property of materials to resist destruction when exposed to external loads. Accordingly, the characteristic of the mechanical strength is the tensile strength - the maximum mechanical stress that causes the glass to break under the action of static load. Depending on the nature of the mechanical impact, the material is characterized by different strength characteristics: tensile strength; for compression; bending; microprocessing; abrasion resistance. For one and the same glass product, the absolute values of these characteristics differ significantly from each other. When considering the strength of glass, it is necessary to clearly define the selected strength characteristic.

Considering the strength characteristics of glass, two different values must be distinguished: theoretical and technical strength of glass.

The theoretical strength is a conditional value calculated for some ideal defect-free homogeneous glass loaded quasi-statically at low temperatures. This

conventional value depends on the nature and strength of chemical bonds in the glass structure and is a characteristic of the material. Accurate calculations of theoretical strength require knowledge of the body structure and interatomic potential. For such complex materials as silicate glass, it is not possible to determine these parameters at the current level of scientific development. Therefore, in evaluating the theoretical strength, they are limited to approximate methods. For the most common silicate glass, the value of theoretical strength is associated with the strength of the chemical bond Si-O-Si.

Technical (or practical) strength is a characteristic of real glass products. The real strength of glass products is determined by surface defects and microcracks arising during the production or operation of these products. These surface defects reduce the strength of the glass and the practical strength of glassware is only 1/1000 to 1/100 of the theoretical value. The strength of glass, like the strength of any other solid, depends on the type of deformation. In practice, glassware can be subjected to tension, compression, torsion, and combinations thereof. In the overwhelming majority of cases, glass is destroyed by breaking stresses during bending.

Numerous experimental data on the strength of glasses show a wide scatter of values and their dependence both on the methods of obtaining samples and the state of their surface, and on the methods and conditions for carrying out strength measurements (temperature, air humidity, load application rate, etc.). The practical strength also depends very much on the geometry of the glass product. So, for ordinary glass products, the tensile strength, as mentioned above, is in the range of 0.02-0.10 GPa, for some special products, such as automotive glass, this value is 0.3-0.5 GPa, and for thin (several microns in diameter) glass fibers reaches 3.5 GPa and more.

To explain the dependence of glass strength on various factors, the concepts of classical fracture mechanics (CFM), Griffith's energy theory of fracture (ETF), linear fracture mechanics (LFM), and kinetic fracture theory (KFT) are used. Crack strain types are shown on the figure 2.1.

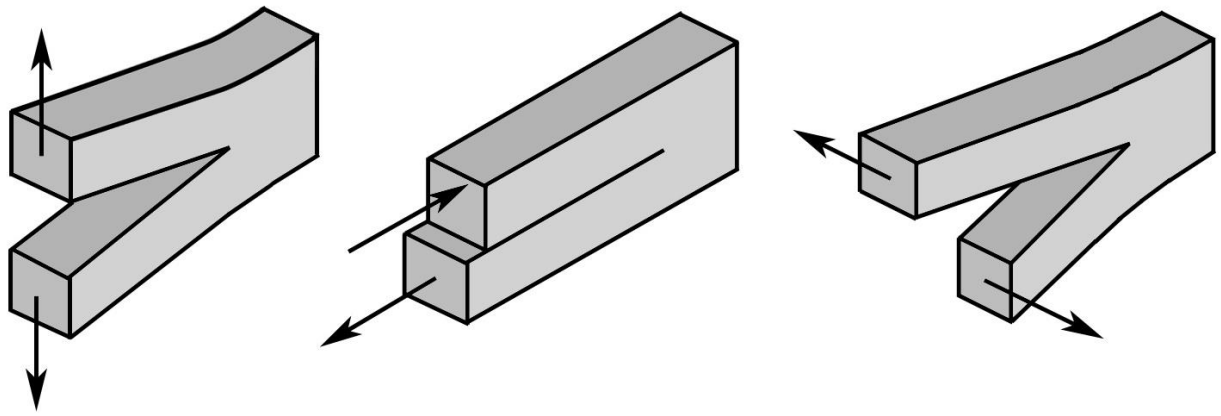

Figure 2.1 – Crack strain types

2.2 Hardness of the glass

The hardness of glass is the ability to resist deformation and destruction of its surface layer. Glass hardness is usually characterized by being pressed into the indenter material, scratched or abraded with an abrasive.

Various experimental techniques have been developed to test the hardness of glass using the indentation of an indenter:

- Vickers method - indentation of a diamond pyramid with an apex angle equal to 136°;
- Knoop's method - indentation of a diamond-shaped diamond pyramid;
- Brinell method - indentation of a steel ball with a diameter of 1 mm.

When testing microhardness by these methods, its value is defined as the ratio of the applied load F to the area of the resulting print. In figure 2.2 shows the characteristic indentations of indenters when measuring microhardness by the Vickers and Knoop methods.

The calculation of the microhardness values by the Vickers and Knoop methods is carried out according to the formulas given under the figures. When determining the microhardness by the Vickers method, the value of l in the formula is the arithmetic mean of the lengths of the imprint diagonals. When calculating the Knoop microhardness using the formula, the value of l is equal to the length of the longer diagonal of the imprint. For hard glasses, the Rockwell method is sometimes

used to determine hardness, which consists in indenting a diamond cone with a hemispherical apex, while the hardness is determined by the difference in the depths of the indentations at different values of the load.

Note that when the indenter is pressed into such a brittle material as glass, there is a risk of cracking at the point of application of the load. Therefore, when measuring the microhardness of glass, the applied loads are small (0.01-2 N). The dimensions of the corresponding imprints on the glass surface are also very small (several microns), therefore, when determining the resistance of the material to the indentation of the indenter, we speak of the microhardness of the glass.

The microhardness of glass depends on the strength of chemical bonds in the material. Therefore, the microhardness of glasses depends on their chemical composition and varies within 4-10 HN / m². Various types of quartz glass (9-10 HN / m²) are characterized by high values of microhardness, and lead silicate glasses (4.2-4.7 HN / m²) have low microhardness.

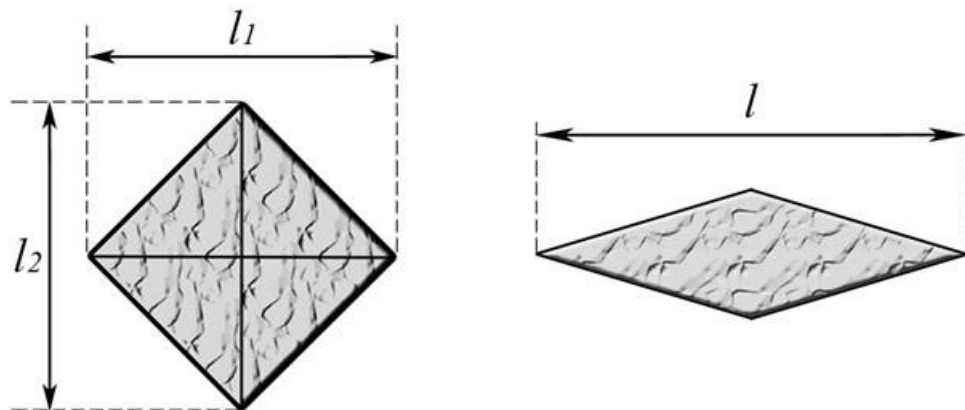

Figure 2.2 – Characteristic indentations of indenters

When discussing the values of the microhardness of glass, it is imperative to indicate by what method this value was determined. Despite the fact that the microhardness values measured by different methods have the same dimension, the microhardness values, for example, according to Vickers, cannot be compared with the values determined according to the Knoop method. Hardness is an important technical characteristic of a material, which determines not only the performance

characteristics, but also its abrasion resistance, technological features of the processing of glass parts - grinding, polishing and cutting. The microhardness of glass can be significantly increased by surface hardening methods, for example, low-temperature ion exchange.

2.3 Fragility of glass

The decisive role of the influence of microdefects on the real strength of glass products has been repeatedly confirmed experimentally. At the same time, this important fact does not answer the question of why exactly glass has such depressingly low strength and is so easy to break. Indeed, scratching a metal product and even significant deformation of its shape often does not lead to its complete destruction. That is, the effect of similar defects on the strength of glass and metal objects is completely different. This is due to the fact that under normal conditions metal is ductile and glass is brittle.

The fragility of glass is its property of being destroyed without plastic deformation under the action of stresses arising in it. According to another definition, the fragility of glass is defined as the ratio of the hardness of a material to its fracture toughness. Glass that is in a solid state (at temperatures below the glass transition interval (the glass transition interval of the most common alkali silicate glass is 500-600°C) is brittle during deformation), in which the relaxation of the arising stresses is difficult. The brittle nature of glass destruction is manifested under conditions when the rate of action of an external applied load is much higher than the rate of relaxation of the arising stresses, for example, upon impact.

In inorganic glasses, strong directed covalent chemical bonds act between atoms, which determine the rigid structural framework of the material. When a load is applied, such bonds do not have time to "switch"; it is not plastic deformation of the material that occurs, but its brittle fracture. As a characteristic of glass fragility, the value of the impact strength a_n can be used, which is the ratio of the work of the impact fracture A_n to the surface area of the cross-section of the sample S :

$$a_n = A_n/S \quad (2.1)$$

For glasses, this value is very small (about two orders of magnitude less than for metals) and amounts to 1.5-2 kN/m. Other quantities characterizing the fragility of glass are the brittleness index and fragility index, determined on the basis of measurements of the microhardness of glass according to Vickers. When the pyramid is pressed into the glass surface under a certain load, an imprint is formed on the glass surface and cracks are formed, as schematically shown in figure 2.3. The greater the fragility of the glass corresponds to the large ratio of the length of the formed crack b to the size of the diagonal of the imprint l .

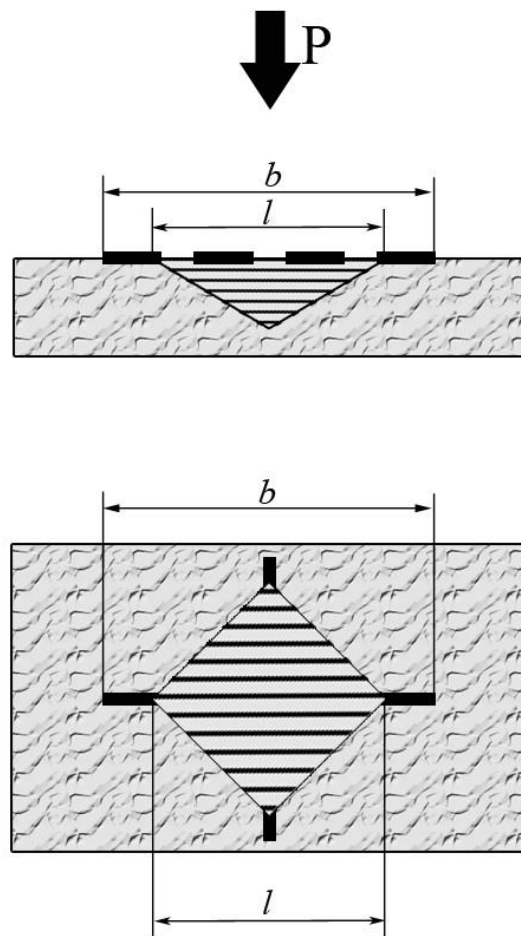

Figure 2.3 – Schematic representation of a fingerprint and a crack

2.4 Griffiths model

The most common model that illustratively explains the strength characteristics of glasses and demonstrates the most important role of surface micro

defects is the Griffiths model. This model is based on consideration of the energy aspects of the processes of destruction of a solid in the presence of micro cracks on its surface. These micro cracks are local violations of the surface layer of glass and are caused by the abrasive action of solid particles or chemical interaction with atmospheric moisture. Such cracks are stress concentrators and stresses arise in them, in magnitude significantly exceeding the external mechanical stresses applied to the sample. Griffiths established that a crack can grow in a loaded body if the released elastic energy exceeds the energy spent on creating new surfaces. This criterion was expressed as:

$$dU/dA \geq dW/dA, \quad (2.2)$$

where U is the decrease in elastic energy and W is the energy of formation of crack surfaces with surface area A .

The glass breakage mechanism includes two successive stages:

- 1) the growth of the most dangerous crack;
- 2) the emergence and simultaneous growth of a large number of secondary cracks.

At the first stage, the growth of the most dangerous (large) crack, located perpendicular to the direction of the applied load, begins at load values exceeding γ_{kr} . The strength of the specimen at this stage is determined by the ratio of the acting force to the cross-sectional area of the specimen minus the area over which the crack has propagated. When the crack reaches a certain critical length, when the true cross-section of the specimen becomes small, and the stress at the crack tip approaches the value of the theoretical strength, the second stage of fracture begins.

In the second stage of fracture, a large number of secondary cracks appear, which grow at a high rate. Meeting with a large first crack and with each other, they form numerous shear lines. The grid of lines of chips gives a rough-shell-like surface. In the fracture of the sample, two zones can be observed corresponding to the stages of destruction: the zone of the mirror surface, due to the growth of one crack; a zone of a rough-concave surface due to the growth of a large number of

cracks. The lower the acting load, the longer the fracture process and the larger part of the fracture is occupied by the mirror surface.

2.5. Young's modulus of glass

If a certain force is applied to a product made of a certain material, then it begins to resist this action: to shrink, stretch or bend. The capacity for such opposition can be measured and expressed mathematically. The name of this strength characteristic is elastic modulus. The parameter is different for each material, and characterizes its strength. They use the value in the development of structures, parts and other products, in order to prevent violation of their integrity.

The modulus of elasticity is a value equal to the ratio of the stress to the elastic relative deformation caused by it.

Depending on the chemical composition, the modulus of normal elasticity of glasses fluctuates within $4.8 \cdot 10^4 \dots 8.3 \cdot 10^4$, the shear modulus is $-2 \cdot 10^4 - 4.5 \cdot 10^4$ MPa. The moduli of elasticity and shear slightly increase when replacing SiO₂ with CaO, B₂O₃, Al₂O₃, MgO, BaO, ZnO, PbO.

For glasses, Hooke's law is valid until destruction. Roughly, the modulus of elasticity can be calculated according to the additivity rule depending on the percentage of oxides in the glass:

$$E = E_1 p_1 + E_2 p_2 + \dots + E_n p_n \quad (2.3)$$

where p_1, p_2, p_n – content of oxides in glass in mass %, and E_1, E_2, E_n – elastic constants of oxides. Table 2.1 shows some of them.

The calculated values can only serve as indicative, approximate ones. Their discrepancy with the actual results of direct measurements is approximately 20-25%.

Table 2.1 - Elastic constants of oxides

Elastic constants of oxides, Gn/m^2	Glass		
	Without B_2O_3	Without PbO, but with B_2O_3	With P_2O_5, B_2O_3, PbO
SiO_2	70	70	70
B_2O_3	-	60	95
ArO_3	40	40	40
P_2O_5	-	-	70
Al_2O_3	180	150	160
CaO	70	70	-
MgO	-	40	30
BaO	-	70	30
ZnO	52	100	-
PbO	46	-	55
Na_2O	61	100	70
K_2O	40	70	30

The elastic modulus of glass depends on heat treatment and decreases when the product is annealed. A sharp decrease in the value of E occurs in the first 8 hours of heat treatment. After the duration of annealing has little effect on the value of the modulus of elasticity. Tempering glass products reduces the modulus of elasticity by 8-10% compared to annealed glass. The treatment of the glass surface by etching or coating it with protective films does not affect the value of the quantity.

2.6. Fracture toughness of the glass

Glass is a linearly elastic brittle material with the predominant influence of surface defects on the strength of the bearing glass elements. These defects, formed during glass production and handling under operating conditions, form a specific fractured surface layer. Under thermal and mechanical loading, microcracks located in the surface layer are more influential than internal technological defects such as

gas bubbles or inclusions, as well as defects in the micro- and nanostructure of glass. The actual statistical distribution of microcracks with different shapes and depths on the surface of a glass element is an important characteristic of the quality of glass, directly related to its structural strength. The average critical depth of microcracks found in the focus of fracture of glass elements under tension and bending is about 30 μm for ordinary float glass. In this case, an average tensile strength of about 60 MPa is typical for short-term testing. The maximum depth of surface microcracks is about 100 microns. Therefore, the lower limit of the results of assessing the ultimate strength under these conditions is close to 30 ... 35 MPa.

The surface defectiveness of glass structures increases significantly under operating conditions. Long scratches and microcracks, abrasive damage, edge chipping, and many other types of damage can reduce the strength of glass structures. Therefore, the technical strength of glass in real practice can be even less than the minimum data based on the test results obtained on standard samples in laboratory conditions, if the production technology and methods of handling glass are carried out without monitoring its surface defectiveness and strength.

Fracture toughness is determined by testing samples with an artificially induced crack by static bending or stretching. The ratio of the dimensions of the sample (thickness, width and length of the crack) is chosen in such a way that a plane deformation state is created in the zone at the crack tip.

Fracture toughness (short-term fracture toughness) tests are among the most approved and theoretically substantiated, which are widely used in the practice of technical metallurgy. These tests are based primarily on linear fracture mechanics, which originates from the work of Griffiths. For the first time, on the basis of the energy approach, he showed that the reason for a sharp discrepancy between the real and theoretical resistance to fracture of solids can be the presence of small defects (cracks) in them, which contribute to the occurrence of stress concentration, reaching theoretical strength in local volumes. Developing the idea of Griffiths, Irwin showed that these local stresses in the most general case of separation loading of a body with a crack are proportional to the so-called stress intensity factor A .

The tests are carried out under eccentric tension or bending on specimens. The specimens are characterized by a sharp notch ending with an induced fatigue crack. It is induced on special vibrators or pulsator-type fatigue machines with asymmetric cycles. To avoid unacceptable work hardening of the material at the crack tip, the maximum K level during cyclic loading during crack induction should not exceed 0.6 of the desired K_{IC} value.

The specificity of determining the fracture toughness lies in the fact that the reliability of the assessment of K_{IC} is regulated by the dimensions of the test sample, which depend on the required value of K_{IC} , subject to the conditions:

$$a \text{ and } B \geq 2.5 (K_{IC}/\sigma_{0.2})^2 \quad (2.4)$$

Therefore, the sizes of the samples have to be selected based on the approximate values of K_{IC} , which are set on the basis of available experience. In this case, it is advisable to assign an estimated value of K_{IC} according to the known values $\sigma_{0.2}$ and E of the material under study.

Finished specimens with an induced crack are tested on standard (but rigid) testing machines. During testing on a two-dimensional recorder, the fracture diagram is automatically adjusted in the coordinates: applied load P and displacement of crack edges V.

According to the test results, the following main characteristics of crack resistance are determined:

- power - critical stress intensity factors K (or K_1): K_{IC} , K_C^* , K_{QT} , K_C ;
- deformation - opening at the crack tip δ_C ;
- energetic - critical values of J-integral J_C or J_{IC}

The determined characteristics of crack resistance (along with other characteristics of mechanical properties) can be used for:

1. comparison of various options for the chemical composition, manufacturing processes, processing and quality control of metals and alloys;
2. comparison of materials when justifying their choice for machines and structures;

3. strength calculations of load-bearing structural elements, taking into account their defectiveness, geometric shapes and operating conditions;
4. analysis of the causes of accidents and destruction of structures.

The state of the surface fractured layer of glass does not remain stable after processing the elements due to the influence of operating conditions. Progressive surface wear affects both optical clarity and mechanical strength. Therefore, in order to guarantee the proper high-strength state of the glass surface, it is necessary to develop special technologies to protect against damage to structural elements, both during processing and subsequent handling.

A high range of strength values is not an inevitable property of glass. To show the real possibility of reducing the scattering of strength values by stabilizing the shape and depth of critical surface microfractures, special experiments were carried out.

2.7 Direct Current Potential Drop Method

The DC potential drop (DCPD) method measures longevity in long-term laboratory improvement tests or short-term tests and examines fracture mechanics problems, fracture hardness, and J-integral measurements. The DCPD method works on the principle of potential reduction as a result of sample homogeneity, for example when one current of sufficient magnitude passes through the entire sample segment.

The main advantage of the DCPD method is that it can analytically predict the drop of its potential for different electrode configurations, different shapes and sizes. Johnson's formula and modifications are one of the most widely used ratios for the analytical description of a weapon and the ratio of the length of a weapon to rectangular models to calculate the front of a straight pistol. Similar statements are made for other forms of fractures, such as angular fractures. Analogous calibration methods or combinations of analogous and analytical methods have been used for many samples and reactive forms.

It should also be noted that issues such as the need for high-voltage power supplies or sample isolation are insignificant compared to the priority benefits of stability, repeatability, and cable sensitivity in the laboratory. Therefore, the mechanics of elastoplastic fracture has recently investigated the possibility of using unusual methods to measure crack length or assess crack development.

2.8 Crack Length Determination by Ultrasonic Methods

The ripped length comes from the size of the brand. A pressure wave is used to track the thickness of the crack. The amplitude of the ultrasonic signal and the crack depth measurement line performed abrasive hole and fracture measurements to purify the penetration depth of the crack. The growth rate is said to be +/- 0.025 mm accurate and the maximum growth rate is +/- 0.25 mm. Specific problems with this technique have been identified as the stability of the bond and the temperature drop due to the weakness and speed of the link. Crack closure also contributes to crack depth measurement errors because the bond between the crack surfaces allows more energy than when the crack is fully open.

Torn length from flight time. With this method, the length of the crack is determined by measuring the length, after which the flying wave spreads to the tip of the crack and the wave appears on the surface. The crack length is calculated as follows:

$$a = [(C_1 t / 2)^2 - h^2]^{1/2}, \quad (2.5)$$

where C_1 is the acoustic velocity of the wave and t is the time of flight. This result can be checked by using:

$$\Delta t = \left(\frac{2}{C_1}\right) (d^2 + h^2)^{\frac{1}{2}} - t, \quad (2.6)$$

where Δt is the difference in flight time of the waves diffracted from the crack tip and reflected from the back surface.

The tolerances when measuring the crack receiver distance or sound velocity are reflected in the calculated crack length. The closure of the cracks can also enhance the resulting diffraction wave effect. This is because diffraction occurs at

more than one point in the fracture. which makes it difficult to measure time. After the structure is loaded, it can measure the depth of cracks up to +/- 0.2 mm.

Penetration wavelength Elastic beam theory is used to predict contextual scattering fields. in this configuration, the eruption is completely underground. And the first wave that reaches the transceiver of the receiver is due to interference from the delayed longitudinal beam at the top of the bomb. The wave represents the modulation of the frequency field as a function of time p :

$$p = \frac{\pi}{a} [\cos\theta - \sin\theta_0] \quad (2.7)$$

Since both θ_0 and a are unknown, two dimensions are required at different angles to measure the parameter gap, but using appropriate injury values, the agreement between their model and the test is almost identical. However, it is important to note that one of the goals of the first knowledge project is to create a better understanding of the expansion of fully open space in many components. Closing such a gap will create low -density waves in the closing zone, which will make it impossible to determine the crack length.

Conclusion to the part 2

Today there are a large number of different methods for assessing the mechanical characteristics of glass, as well as their resistance to destruction. All of these methods are based on different principles and are quite difficult to implement. Therefore, the determination of their mechanical characteristics, as well as the development of methods for their assessment is an urgent task.

The scope of glass is determined by their properties. Therefore, depending on the methods of their research, the selection of material for various types of structures depends. The chemical composition of glass, the method of its heat treatment, as well as the presence of defects and microroughnesses have a significant effect on the results of mechanical characteristics.

The modulus of elasticity of glasses is in the range of 45 – 98 GPa. The higher the brittleness index of the material, the lower the deformation, the stress in the

material reaches its ultimate strength. The structural strength of glass is not a well-known property that remains "opaque" for most people in the glass industry.

When assessing the bearing capacity of real glass structural elements, it is necessary to analyze the influence of surface defectiveness, stress corrosion, as well as production technology and many other factors. All these factors significantly affect the structural strength of glass.

Using the kinetic theory of fracture mechanics and data on initial defects in glass elements, in certain cases, the influence of loading conditions, structural and technological factors on the technical strength of glass can be estimated. Accurate calculation of the stress intensity factor on a given component under load relies on an accurate size determination of the flaws present in the component.

PART 3

INVESTIGATION OF THE MECHANICAL PROPERTIES OF GLASS BY SCRATCH TEST METHOD

The method of sclerometry is based on continuous registration of resistance movement of the indenter on the surface with a given load. Determining the statistical relationships between the supports of local microvolumes of material by contact deformation allows to make a comprehensive assessment of the state of the surface layer on the scanning route and, in particular, allows:

- estimate the average strength of the surface layer on the track scanning;
- evaluate the scatter and inhomogeneity of strength;
- to model elementary acts of friction and wear processes (micro-cutting, micro-sliding, brittle fracture, etc.);
- evaluate the adhesive strength of thin films and coatings;
- measure microhardness by scratching.

3.1. Scratch hardness

Since 1822, Moss has a long history of drawing experimental materials, and Moss supplies 10 reference metals that can maintain their significance in minerals. Due to the technical difficulties of this technology, the local indexing method has completely changed the sclerometer method in engineering practice, and in the last ten years, Scratched silver has become popular in the study of the physical and mechanical properties of various materials. . Thin film and superficial and tribological examination

When measuring stiffness, the sample mounted on the motor slide is pressed against the surface of the sample (product) under the influence of a continuous continuous load and the sample mounted on the motor slide is moved. As a result, the plows are at the top of the design, depending on the depth and thickness of the robust material. The second is related not only to hardness but also to the actual resistance to metal cracks (especially when it comes to plastic).

There are three test results.

Due to the thickness (or depth), the load on the inductor depends on the load; the size of the image obtained from the load used in inductance;

1. The amount of tangential force to form a normal load line acting on the inductor.
2. By standard The sclerometric microrupture test uses a grid or a triangular diamond pyramid to measure normal load motion and its thickness.
3. The contact area according to the state of a pyramid indicates the contact area of the pyramid according to the microchip formula.

The number of micro-gardens, usually divided by normal load:

$$H_{VP} = \frac{3.138P}{b^2}, \quad (3.1)$$

where P is the normal load, kgf; b - scratch width, mm.

The test surface should be flat, free of contaminants, roughness should not be lower than $R_a = 0.32 \mu\text{m}$. The test specimen must be placed on the instrument table so that it does not move, bend or rotate during the test. The surface to be examined must be installed perpendicular to the axis of the indenter.

3.2 Scratch test

When a lateral retraction is performed, micro-nanoparticles may be examined to allow the interpretation of qualitative trends. To some extent, this prevents some of the heavier tests or surgeries that come with similar rehabilitation tests. The behavior of the rope may be influenced by the tip geometry and the normal load. These experiments can provide important insights into improving the abrasion resistance of micro- and nano-surfaces. By simultaneously performing a step and observing the friction coefficient, mechanical information about surface defects can be generated. During the nanoscrapping process, the interface will feel different loads including standard and side components. In this sense, scratch tests can be more meaningful in determining durability by determining shear and wear resistance

across multiple length scales. The nanoscratch test consists of three main stages, namely Prescan, Scratch and Postscan (Figure 3.1).

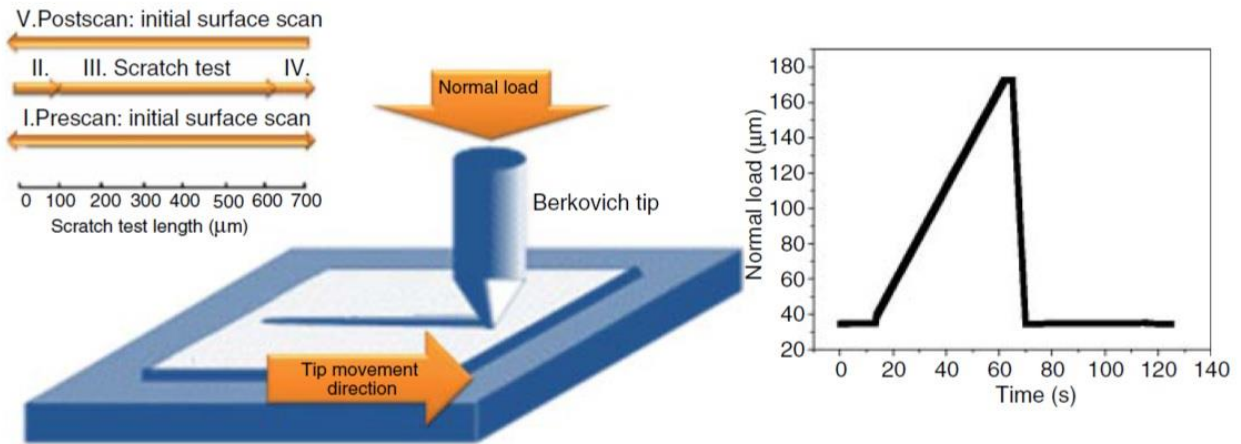

Figure 3.1 – Scratch testing method

The standard protocol usually has the first small scale scan (1 N). The pants are then used to screw the sample under special pressure to form a screw; Weights range between 50 and 140 microns and the belts are usually 1010 cm long. Scale), three measurements obtained from different sample locations (up to 50 m) for mathematical reasons. Nanocratic and post-stable testing can be performed to test the resistance of both textured and tangential surfaces.

If you compare nano-step and post-nano-step by step, closed underground interactions can be demonstrated on comparisons that are not closed. After nano-scratching tests, SEM images are obtained to ensure high scratch resistance.

3.3 Instrumental description of scratch test

The multifunctional device "Micron-gamma" is shown on the figure 3.2 and is designed to study the physical and mechanical properties of the surface layers of materials by instrumental indentation, sclerometry and metallography.

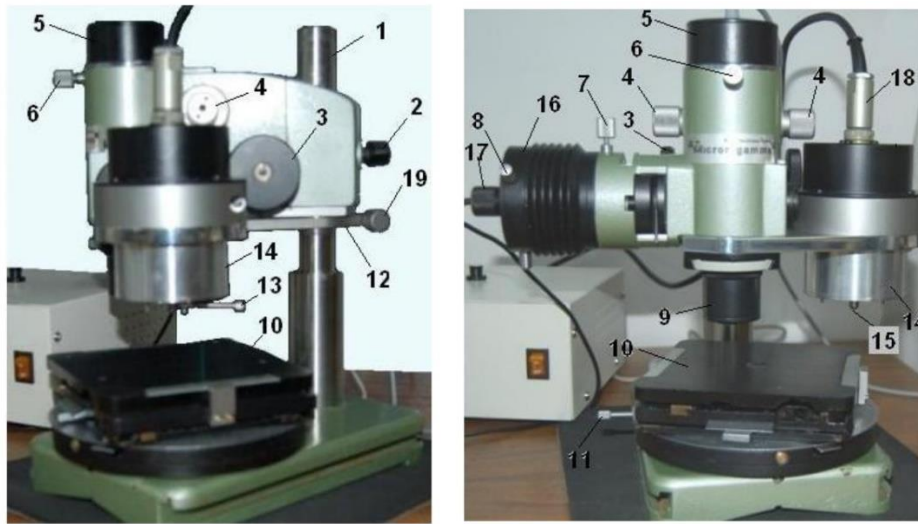

Figure 3.2 – Device for measuring micromechanical properties materials

1 - rack; 2 - the handle of fixing of a microscope on a rack; 3 - the handle of rough adjustment of a microscope and an indenter; 4 - the handle of the mechanism of micrometric adjustment of a microscope; 5 - video camera; 6 - the screw of fastening of the camera; 7 - the screw of fastening of the illuminator; 8 - centering the screws of the illuminator; 9 - lens; 10 - two-coordinate table; 11 - screw fixing the table rotation; 12 - target injection limiter; 13 - probe handle; 14 - load unit; 15 - indenter; 16 - illuminator of the microscope; 17 - cartridge with high brightness LED; 18 - connector of the load unit; 19 - fixing screw.

Design of the device "Micron-gamma". The device consists of frame with rack 1, two-coordinate mechanized table 10, optical microscope with interchangeable lens 9 and video camera 5, load unit 14 with built-in inductive sensor of small movements, electromagnetic loader and diamond indenter 15.

The load unit 14 and the microscope are rigidly connected, and the optical axis of the microscope and the indenter 15 are located on the same radius relative to the axis of the rack 1. The microscope with the load unit 14 rotates around the rack 1 at an angle proportional to the distance between the optical axis and the injection. The angle of rotation is limited by the limiter 12. The limiter 12 is fixed on the rack 1 with a screw. The limiter 12 is also a support for the microscope. The handle 2 is used to fix the microscope during transfer. In the case of a small tightening of the handle 2 eliminates the backlash when turning the microscope. The tightening force

of the handle 2 is selected so that you can turn the microscope relative to the rack 1 with little friction.

The two-coordinate table 10 can rotate around its own axis, and the screw 11 serves to fix the selected position, for example when scanning. The magnitude of the rotation is calculated on a scale with a division price of 2° . Movement in the horizontal plane in two mutually perpendicular directions (X and Y coordinates) is carried out by built-in micromotors with reducers. The amount of movement of the table and its coordinates are calculated on scales and vernier with an accuracy of 0.1 mm. The handle of the probe 13 is used to adjust the height of the probe. Twisting (turning around the axis of the probe) shorten the probe and vice versa. At the top of the tube is a color video camera 5, which can be rotated around a vertical axis to position the image relative to the monitor screen and fixed with a screw 6. If the dimensions of the sample are such that there is not enough stroke in height, you can raise the microscope on the rack 1.

The illuminator 16 is fixed to the microscope tube with a screw 7 and contains a white LED of high brightness, which reduces the power consumption by an order of magnitude in contrast to the incandescent lamp and, accordingly, reduces the heating of the tube with the loader. The cartridge 17 with the LED is centered by turning the screws 8. Necessary conditions for working with the device:

- the temperature in the room where the inspection is carried out should be $(20 \pm 5)^\circ \text{C}$, relative humidity - not more than 80%;
- maximum permissible vibration speed at the installation site - 0.315 mm / s for the frequency range up to 100 Hz. It is recommended to use a vibration isolator to reduce the effects of vibration.

The principle of operation of the device "Micron-gamma" (figure 3.3). The rod 4 with the indenter 5 and the probe 9 are fixed to the body of the loader unit 3 by means of flat springs 6 and 10. The springs allow the rod 4 and the probe 9 to move in a strictly vertical direction within 0.5 mm.

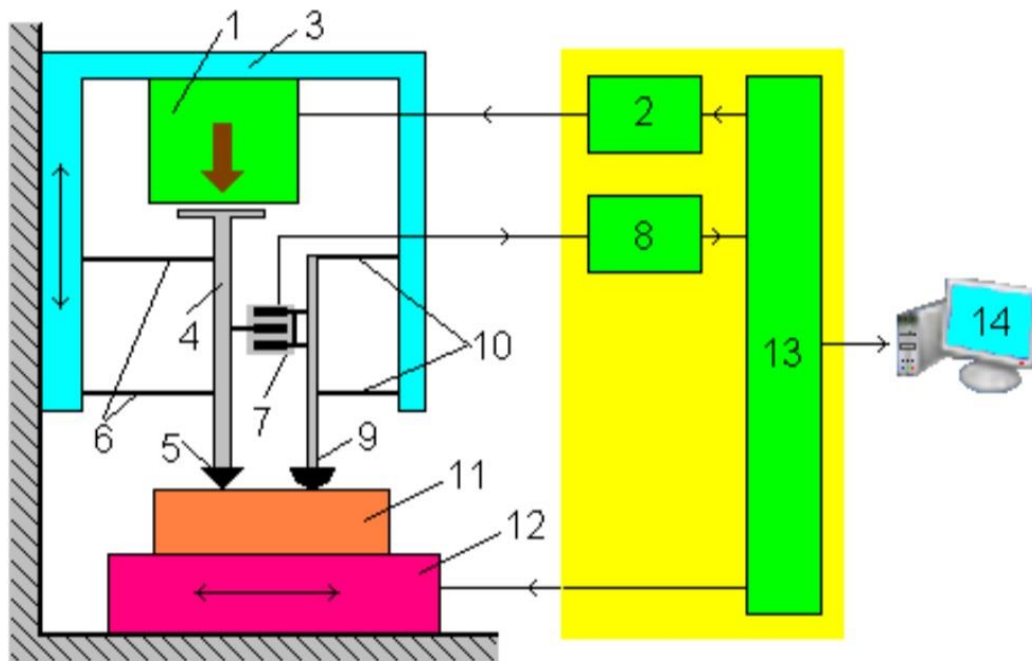

Figure 3.3 – Block diagram of the device

1 - electromagnetic loader; 2 - DAC; 3 - housing of the load unit; 4 - stock; 5 - indenter; 6 - flat indenter springs; 7 - sensor of small movements; 8 - ADC; 9 - probe; 10 - flat springs of the probe; 11 - sample; 12 - subject table; 13 - microprocessor; 14 - computer.

Gradually lowering the housing of the load unit 3, install the indenter 5 and the probe 9 on the surface of the sample 11. In the process of loading the indenter 5 is registering the depth of its introduction relative to the probe 9 (relative to the sample surface). After starting the software of the device and selecting the required load and speed, load the indenter with an electromagnetic loader controlled by a digital-to-analog converter (DAC) 2.

In the process of loading the indenter 5 is the registration of the depth of its immersion relative to the probe 9 (ie the surface of the sample). The depth of immersion is registered by the sensor of small displacements 7 by means of analog-to-digital converter (ADC) 8. The housing of the sensor 7 is attached to the probe 9 and the armature (moving part) to the rod 4 with indenter 5. Thus, the sensor 7 always measures the movement of the rod indenter 5 relative to the probe 9. The microprocessor 13 serves to control the ADC, DAC, two-coordinate subject table 12 and generates communication protocols with the computer. The use of a probe

(differential measurement method) can reduce the impact of vibration and rigidity of the device on the readings tenfold, as it measures the depth of indenter indentation relative to the probe, ie - the surface, not the deflections of the table and rack.

3.4. Results and discussions

Corrosion resistance by Inditor Bergovits's advanced microbiological abrasives method. The order of developmental stages of fracture along the fracture is determined by the load applied to the crevice. A special data system has been proposed to study the degree of breakage of glass when scratched under increased load.

Previously, the SEVNB method was used for comparative mechanical examination of glass with a single-sided V-beam, which allowed to destroy a rounded rectangular pattern with a V-beam. Its essence was to determine the fracture toughness of the specimen. . Margin when entering a retreat. However, in this case, the surface of the standardized material \perp the surface layer is first eroded by a sharp hole, \perp only after that cracks appear in them, the size of which determines the hardness of the fracture. In this case, too, the resistance to destruction of the surface \perp surface layers of the test material was not evaluated.

The stiffness scale (general) is widely used to evaluate the mechanical properties of the building surface. Nano-painting technique makes it very useful to evaluate the mechanical properties of the surface layers. This technique is successfully used to assess the condition of the surface layers of a material by determining the abrasion resistance of the material. Using this method, it is possible to determine the accuracy of the material under study \perp the racial properties of the surface layers.

This technique allows to study the microscopic mechanical properties of glass, crack resistance, hardness, corrosion resistance at microfinance levels in conditions close to the actual operating or technical processes. It should be noted that there are some discrepancies between the depth and scratch hardness of glass, which should be taken into account when creating new materials with advanced mechanical

properties. It is known that the refractive properties of glass are affected by the environment.

Erosion studies of the glass surface μ adjacent layer show differences in fracture severity. At the same time, an increase in resistance to breakage of the surface layer of glass was observed, which is not typical for further layers of this material. In this case, when applying the scratch, the cause of the scratch is directly determined. The process of glass damage was studied with the help of the original Micron-G device to determine the physico-mechanical properties of the surface layers of the material by continuous nanofracture μ nanofraction with different types of niches. The level of the material structure moves at a constant speed of 22 m / s. The inductor is charged with an electromagnet. The maximum load force of the niche is 4 N. The displacement inside a normal diamond is measured by an induction sensor with a sensitivity of 5 nm.

When moving a mass of objects with a model, the role of any frame with inductive load is confirmed, as the F_F button is registered on its motion-motion resistance. Draw the slope of the specimen μ surface in shooting mode. In advanced compression mode, the absorption load increases to a certain value of F_N and then decreases to an F_{min} value. In steady state demolition mode, the injection load with F_{min} increases to a certain value of F_N in the first second, and in the case of a constant load, it continues to use the test surface for a certain period of time.

During the cutting process, tertiary (resistance force F_F), Sclerography (normal retraction) are recorded, the target is imaged with a built-in digital microscope, fingerprints are recorded, and micrographs are recorded.

The mechanical properties of the tested glass are given in Table 3.1. Glass hardness μ fracture toughness were determined using woven integers. In addition, the correct mechanical properties were confirmed by continuous injection of the Bergovich index at a load rate of 500 mN at a load rate of 50 mN / s.

Table 3.1 – Mechanical characteristics of the glasses

Material	Microhardness, H [GPa] (Dispersion)	Elastic modulus, E [GPa] (Dispersion)	Load of lateral crack, F_L [mN] (Dispersion)	Fracture toughness, K_{IC} [$MPa \cdot m^{1/2}$] (Dispersion)
Quartz glass	11.1 (<1%)	69.7 (<1%)	50 (30%)	0.8
Float glass	8.4 (<1%)	76.9 (<1%)	60 (30%)	1.03
Fused silica KI	11.3 (<1%)	71.2 (<1%)	30 (20%)	0.77
Light krone	8.8 (<1%)	78.1 (<1%)	40 (25%)	0.91
Flint TF-1	5.6 (<1%)	58.7 (<1%)	70	0.85
Heavy flint TF-2	5.9 (<1%)	60.7 (<1%)	100	0.83

At the beginning of this study, similar to the literature data, scratches with a length of 2 mm were made on the surfaces of glass samples by a progressive method (figure 3.4) with a maximum load on the indenter equal to 120 gf, reaching in the middle of the scratch. It was noticed that as the load on the indenter increases, three stages of microfracture are formed. The first, initial (I) stage of ductile-brittle microfracture ends at a scratch area of 440 μm , when the load reaches 50 gf.

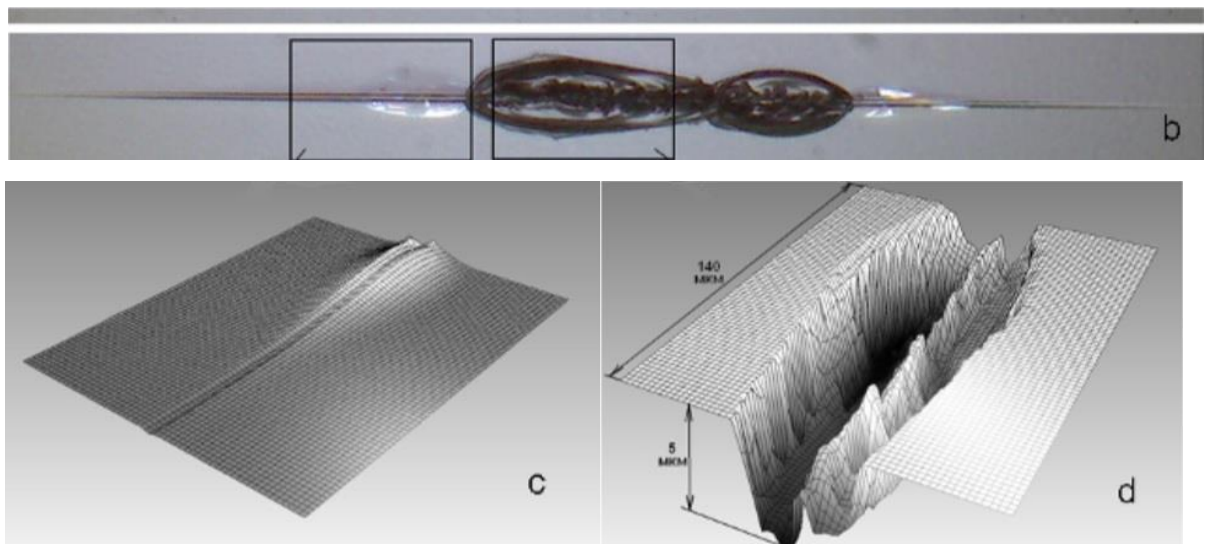

Figure 3.4 – Example of scratch on the sample

Then, when the load increases to 100 gf, the second (II) phase of the lateral capture starts at 440-820 μm . An additional increase in load at 120 gf, in a cross section of 820–1000 μm , leads to a third (III) fracture, in which the growth of lateral cracks stops and the radial cracks form a nucleus, forming a small depth . a. scratched parts with broken edges. Moreover, when the load is reduced to 50 gf in the range 1000-1600 microns, the transformation of phase III to phase I, passes phase II without causing lateral fractures. In addition, it was observed that lateral cracks formed in stage II continued to spread long after the completion of the vaccination process (from a few minutes to a few hours), followed by scale formation.

Quartz glass is used as a model for a detailed study of the mechanism of cracking and dispersion in glass. Preliminary studies have shown that side cracks in this glass occur with lower scratch loads than LK-5, TF-2 and more. The scratch improvement of the quartz glass area was then carried out in three phases with a maximum load of 40 gf between the scratch areas. In the first stage, the surface (slope) of the test sample with an attractive load of 0.1 gf was recorded. Such low loads allow first-position profiles to be written without obvious damage, similar to profiles given Berkovich's capture geometry. Then, returning to the starting position (at the beginning), on the same track (increasing with increasing load), continuous itching is performed only in the middle, with sclerogram recording on a large tractor load, which reaches . or 40 gf. . At the end of this experiment, in the third phase, after returning to the original position, the current topography of the scratches ("profile") with a low traction load (0.1 gf) was recorded.

As seen from the sclerogram, the effect with enlarged scratches penetrates smoothly into the sample surface; Destroy the glass in it.

However, according to the micrograph "profile" taken initially, after this release, the destruction starts earlier (at low loads). In addition, the erosion zone expands over time near the scratch on the other side of the scratch site. Therefore, determining the load size on the side of the micrograph socket does not allow you to get reliable results. Side cracks under the moving handle start to spread after the load is removed.

Within 20 hours after the examination, there was a further increase in the severity of the case.

Striking experiments were performed to change the detailed aspects of the ship's development period. In the case of Berkovich Bull inhalers, subriapine was used for continuous scanning with a maximum increase of 20 cN when no lateral layers formed.





When the voltage reached 20 cN, immediately after the bucket we examined the microscope during the day. However, 24 years later, when pus appeared under the microscope, the trees appeared without side marks, side tubes - sheath.

To upgrade the login profile key. A short analysis slide shows how side effects develop, even the controlled fall of a ball over a small head. Within an hour the shell exploded and the shell formed. In addition, the shells may have straight edges, and in the middle, behind the spanning bridge, they have a low odor.

The maximum distance is 5 μm . Analyzing these results, it is clear that the appearance of cracks on the sides (bladders) of different cups is the same, but, as shown by the test results, the yellow is similar to many other cups. The only difference is the load on the scraper from which the cracks appear. The load distribution values of P_L thwalo, when lateral cracks begin to form in the tested glass, are given in Table 5.2.

Table 5.2 – Lateral cracks and loads

Glass	Micro photos of the lateral cracks	Load of lateral crack, F_L [mN], (Dispersion)
Obsidian		900 (35%)

Float glass		600 (30%)
Fused silica KI		300 (20%)
Light krone		400 (25%)
Flint TF-1		800 (45%)
Heavy flint TF-2		650 (40%)

It can be assumed that the stages of the formation of lateral the shells are strictly sequential, and they are formed not only during the scratching process, but also after scratching the test sample. Lateral fissures, over time, can spread along the banks of fine scratches, which then develop into large shells. The emergence and propagation of lateral cracks is facilitated by the stress formed during scratching and the water adsorbed from the air. Surface-active water molecules, getting into microcracks, push it apart due to the wedging action (Rebinder effect) and contribute to the further propagation of the crack.

The results obtained can be useful both in assessing the performance of glasses under various conditions of their practical application, as well as in choosing the modes of their mechanical treatment.

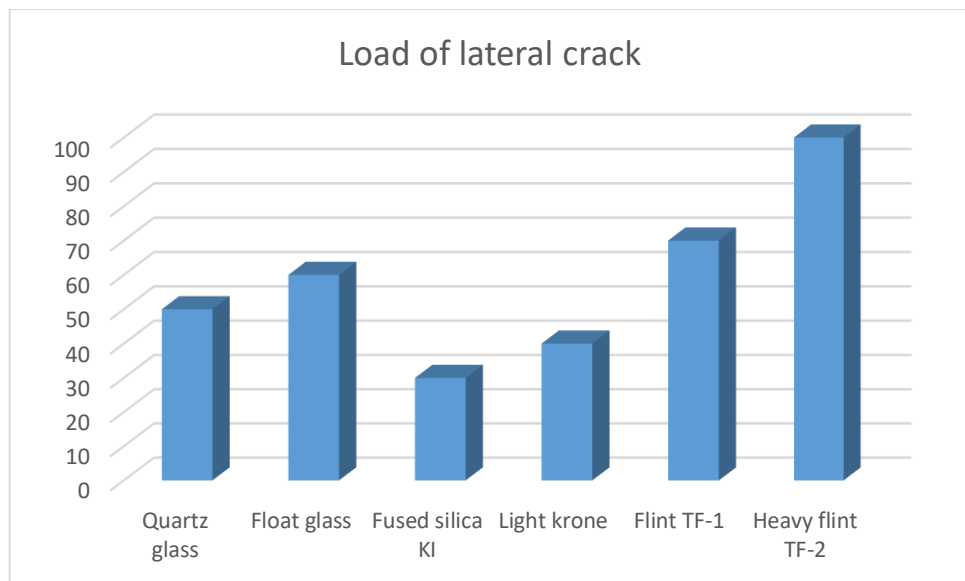
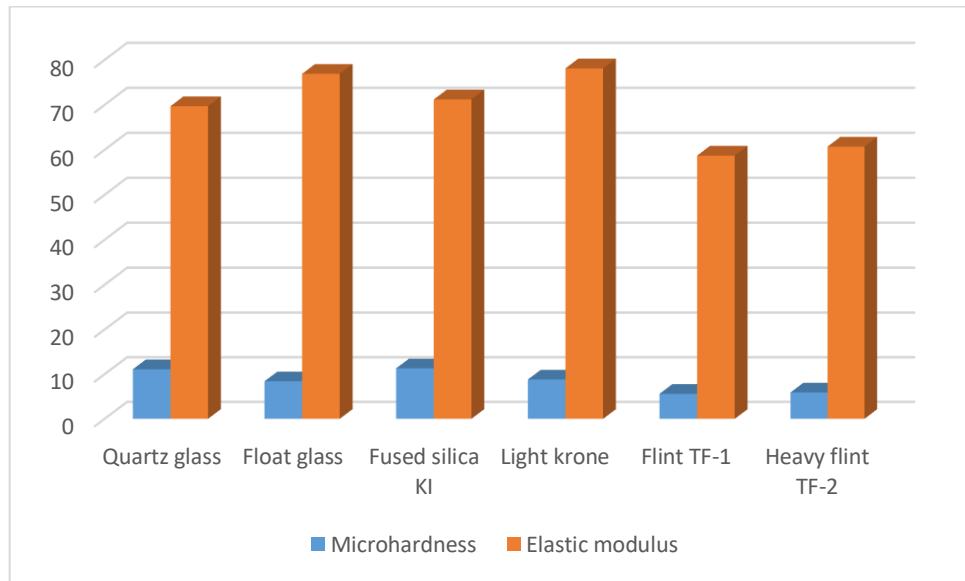

Conclusion to the part 3

Experimental studies on glass microfractures have revealed that when using the continuous download method, the side effects of the blast multiply after use. The disjoint side remains long up to a few hours after surgery. It is difficult to determine the amount of pressure that creates cracks.

Burial of the glass fields examined at regular intervals and at short distances is recommended. This allows for short-term damage detection. This will help determine the size of the parts of the product. A small significant effect of glass corrosion on the process was observed during the test. For example, in the presence of water, it is easier for cracks to form and propagate in the top layer of glass products. Their cracking in the smallest places. The maximum weight occurs due to the effect of atmospheric heat loss on the glass if damaged.

PART 4

LABOUR PROTECTION

4.1 Introduction

This diploma work is based on glass experimental work and covers its production methods. The production of materials is always associated with an enterprise or plant, which implies the presence of personnel. The subject of this work is an operator in the glass industry. This chapter covers working conditions in the glass manufacturing industry, safety precautions and investigation of the harmful impact.

4.2 Analysis of working conditions

Correctly organized work to ensure labor safety increases the discipline of employees, which, in turn, leads to an increase in labor productivity, a decrease in the number of accidents, equipment breakdowns and other emergency situations, that is, ultimately increases production efficiency.

4.2.1 Harmful substances in the air of the work area

In glass production, one of the main factors that can have an adverse effect on the body of those working in compound departments is the dust generated throughout the entire process of making up the charge. In non-mechanized industries, the main reason for the dustiness of the air in these premises is the conduct of many operations manually without rational shelters with appropriate dust extraction at the place of its formation.

In mechanized compound compartments, dust pollution of the air in the working rooms occurs if the mechanisms used are not hermetically sealed and the exhaust ventilation from them is ineffective. Dusting during the operation of roll and hammer crushers occurs, in particular, mainly due to leaks in the casing of the disintegrator, in addition, through leaks in the joints with the casing, in chutes and

channels for feeding materials. During the operation of runners, ball mill, jaw crusher, etc., dusting occurs when loading and unloading material.

In sieving operations, a particularly high dust content is observed when using hand sieves, open screens or when manually wiping materials through very fine sieves. With mechanized sifting, when the devices are closed with casings, the release of dust into the room is possible through inspection or loading openings. The dustiness of the room air can be greatly influenced by the repetitive weighing processes of the charge components. A lot of dust formation is observed during loading and unloading of all types of mixers. Finally, it is necessary to point out the possibility of dusting during the operation of transport devices, which in the compound compartments are represented by belt and screw conveyors, bucket elevators and all kinds of feeders. In these cases, dusting occurs mainly in the areas of material drop.

The charge in its composition, due to the heterogeneity of its constituent components, is very diverse. In accordance with this, the dust formed in the air of different sections of the compound compartment may differ significantly in its qualitative composition. Its high dispersion allows it to spread relatively easily throughout the entire compound compartment.

The content of dust particles in the air of the working area is determined by weighing the dust deposited on the filter as a result of drawing a certain volume of air through an AFA type filter (aerosol filter). The dust concentration is calculated using the formula:

$$P = (g^2 - g^1) \cdot \frac{1000}{V} \quad (4.1)$$

P - dust concentration, mg/m;

g^1 - is the mass of the pure filter, g;

g^2 - is the mass of the filter with dust, g;

V - is the volume of extended air reduced to normal conditions, m³.

Air intake was carried out with an electric aspirator for 75 minutes at a rate of 18 liters per minute. The weight of the filter before air suction is 0.015g, and after

sampling - 0.380 g. The air temperature at the moment of sampling is 20°C, barometric pressure is 760 mm Hg.

$$P = (0.38 - 0.015) \cdot \frac{1000}{1350} = 270.37 \text{ mg/m}^3 \quad (4.2)$$

Fighting dust in the workplace is essential. Its presence, especially in excessive quantities, negatively affects the health of every employee of the company, leading to chronic diseases. There are methods for cleaning the air from dust. To eliminate contamination, it is customary to use special air conditioning equipment and filters for cleaning; a specialized ventilation system is being developed.

To remove settled dust, centralized pneumatic dust collection systems are installed. Primarily, these systems should be used in unheated industrial buildings where hydraulic cleaning is not applicable. Taking into account the large areas to be cleaned from dust, it is recommended to provide dust removal systems with a range of up to 200 m and a number of simultaneously connected nozzles up to 10 pieces in all main shops.

4.2.2. Heat effect

Workers are exposed to heat radiation and high air temperatures in various production operations, but mainly on sites near furnaces. Sources of release of large amounts of heat into production facilities are glass-melting and auxiliary furnaces (machine-bath and pot furnaces, bakeries, non-mechanized annealing furnaces, lera, etc.). as well as molten glass coming from the ovens, and the glass products themselves during their processing.

The air temperature at workplaces near glass furnaces can reach 35-45°C and above. High temperatures, reaching 40°C and more, are also noted at workplaces near leers and other annealing furnaces, near which workers stay, albeit for a short time, but often during the shift.

Glass compositors are most often exposed to heat radiation. During a frequently repeated operation of a set of molten glass, lasting 3-7 seconds, the intensity of the radiant energy directly at the furnace window can be from 5 to 9

cal/cm²*min. As you move away from the window with a portion of molten glass, the compositor of glass continues to be exposed to heat radiation, the intensity of which decreases to 2–2.5 cal/cm²*min.

The intensity of thermal radiation at the press operator's workplace during the pressing of screens for cathode-ray tubes is up to 3 cal/cm²*min. At windowers, in which cones and screens for cathode-ray tubes are heated, the worker can be exposed to thermal radiation with an intensity of up to 7 cal/cm²*min. For cone and screen welding machines, the intensity of thermal radiation reaches 5 cal/cm² *min.

In more favorable conditions are the operators who service the blow molding machines, since the intensity of thermal radiation at their workplaces does not exceed 1 cal/cm²*min.

Heating microclimate conditions are created in the hot shop of a glass factory with a heat release of more than 23 W / m³. It is characterized by the predominance of radiant heat, which is the main climate-forming factor. Up to 70% of the heat is emitted as infrared radiation (radiation heat). The intensity of infrared radiation can reach from 2100 W / m² to 14000 W / m².

Infrared radiation is periodic electromagnetic oscillations with a wavelength of 0.76-1000 microns, which is emitted by a heated body (in this case, molten glass). It obeys the following basic physical laws:

1. This heat completely absorbs all radiation incident on it.
2. A thermal emitter, which has the highest radiation power at a given temperature for all waves, in comparison with other emitters.

The introduction of a high-temperature process leads to an increase in the spectrum of short-wave rays and the appearance of ultraviolet radiation. The effect of the heating microclimate on the body can manifest itself in the occurrence of the following syndromes:

- 1) neurasthenic
- 2) anemic
- 3) cardiovascular
- 4) gastrointestinal

Optimal microclimatic conditions according to the criteria of the optimal thermal state of a person dressed in a set of clothes with thermal insulation of 1 clod in the cold season and 0.7-0.8 clos in the warm season. They provide a general and local sensation of thermal comfort during a work shift with a minimum stress of thermoregulation mechanisms, do not cause deviations in the state of health, and create the prerequisites for a high level of performance. Workers must be provided in accordance with the established standards with overalls and personal protective equipment: cotton semi-overalls, a respirator, antistatic shoes.

4.2.3 Production noise

Another unfavorable factor in composite compartments is the noise during operation of crushers, mechanized screens and other equipment, reaching 92-95 db. The noise that occurs during the operation of production equipment and exceeds the standard values affects the central and autonomic nervous system of a person, and the organs of hearing.

Also, the main preventive measure in production aimed at reducing noise is the effective protection of workers from the adverse effects of noise, which requires the implementation of a whole range of organizational, technical and medical measures at the stages of design, construction and operation of industrial enterprises, machinery and equipment.

The first group of events is technological. They are aimed at changing the technology of the processes and the design of the machines that are the source of noise. Measures of this type include:

- 1) replacement of noisy processes by noiseless ones;
- 2) shock-free shock processes;
- 3) reciprocating movements are replaced by rotary ones (replacement of riveting by welding, forging and stamping - by pressure treatment), etc.

The second group of measures - a technical group of measures is primarily aimed at reducing noise and vibration of parts, especially those with large vibrating surfaces, by:

1) lining them with materials that absorb noise and vibration (rubber, cardboard, felt, asbestos, bitumen cardboard, sound-reducing film);

2) the use of sound-insulating (damping) linings, skins, spacers, gaskets for impact treatment of large surfaces;

3) good insulation when installing machines and units on foundations, preventing the spread of vibration and noise through the foundations, floors, ceilings.

For example, sound-insulating sheathing of tumbling drums, ball mills, installation of damping gaskets under the straightening plate, the use of clamps and spacers when processing figured parts is carried out; 4) the use of mufflers to absorb noise during air exhaust, which makes it possible to reduce aerodynamic noise by 50-80 dB.

If it is impossible to reduce the noise in its source, the noise-reducing units are isolated in separate noise-insulating rooms or closed with noise-insulating casings, and the workplace is removed at a certain distance with the organization of remote control. At the same time, the walls of the premises are equipped with acoustic plaster, tiles, facing panels in order to reduce noise due to multiple reflections from internal surfaces.

The third group of measures is sanitary and hygienic measures and organizational measures. These include:

1) measures for measuring noise at workplaces, decoding of the data obtained, conclusion on the results obtained on working conditions at workplaces of noisy industries;

2) reducing the time of contact with noise, building a rational regime of work and rest, providing for short breaks during the day to restore hearing function in quiet rooms, combining professions;

3) the use of personal protective equipment for hearing from the effects of noise. Currently, the country uses dozens of options for ear plugs, headphones and helmets designed to isolate the external auditory canal from noise of various spectral composition.

The fourth group of activities is medical and preventive. Conducting preliminary and periodic medical examinations. Such examinations are subject to persons working in industries where the noise exceeds the maximum permissible level (MPL) in any octave band. Also, medical and preventive measures include the organization of therapeutic and prophylactic nutrition, general strengthening therapy (vitamin therapy).

4.2.4 Fire protection

As a measure of compliance with labor protection, it is also necessary to include a fire safety item. Fire safety is included in the complex of labor protection measures, and organizational work in this area at economic facilities includes a wide range of activities, including:

- 1) Monitoring compliance with fire safety requirements and legal norms
- 2) Development and implementation of regulations for extinguishing fires, evacuation and rescue from places of fire and smoke of people and property (material values)
- 3) Compliance with the evacuation plan (Figure 4.1).

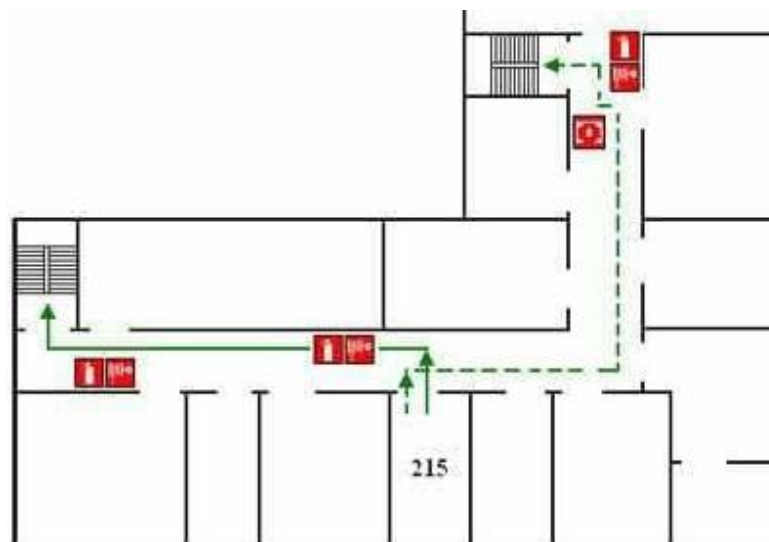

Figure 4.1 - Example of emergency evacuation scheme

The requirements for fire safety at the enterprise must be strictly observed by each employee, and the organizational component is assigned to officials according

to the appropriate decision of the management and is prescribed in job descriptions and regulations for structural divisions.

In particular, specific territories, areas, zones, objects, entire buildings and their parts, floors, on which the responsible officer should carry out such organizational work, are indicated.

It should also provide for the creation of a voluntary fire department and a fire and rescue team within it.

Conclusion to part 4

In the compound departments of glass production, hygiene measures should first of all be aimed at combating with the main harmful factor - dust. The most successful dedusting of air in composite and ceramic compartments is possible only with complete mechanization of the entire production process, ensuring the tightness of the equipment, its shelters and transport routes, as well as with the mandatory collection and removal of dust in places of its formation. All processes of transportation and preparation of charge components, both basic and auxiliary, used in small quantities, their mixing, transportation of the finished charge and its loading into a glass-making furnace should be mechanized.

Simultaneously with the mechanization of processes in composite and ceramic compartments, great attention should be paid to the effective shelter of all equipment, including transport routes (elevators, augers, etc.). However, it is not enough to provide equipment with sealed shelters; it is necessary to systematically monitor its condition. Sealing equipment allows you to drastically reduce or even completely eliminate dustiness in the air, however, the lack of systematic supervision over the condition of the shelters leads to the fact that, due to the leakage that inevitably occurs during the operation of the equipment, dust begins to penetrate from under the shelter into the air of the room. Long-term experience shows that in new, mechanized industries, even with covered equipment, high dust content can occur, precisely due to the leakage of the shelters.

The room in which work with fiberglass or fiberglass products is carried out must be isolated from other production areas and equipped with a supply and exhaust ventilation system with air purification and collection of waste generated during the processing of this material. Sealed fiberglass chambers should be equipped with devices for moving parts inside the chamber. These devices are controlled from the outside of the camera. Observation of the processes in the chamber should be carried out through special windows with glasses of the required strength. The grooves for the hands in the closed chamber should not have gaps through which fiberglass dust can enter the room. Elastic gloves and armbands in the hand slots must be made as one piece.

PART 5

DIFFERENT SOURCES OF GLASS FOR AIRCRAFT INDUSTRY

5.1 Glass resources and how they effects on the environment

The raw materials used in glass production are divided into main glass forming materials and auxiliary materials. Depending on the main glass-forming substance used, glasses are oxide (silicate, quartz, germanate, phosphate, borate), fluoride, sulfide, etc. Among them there are two types that are most common in the aviation industry.

The first is silicate glass. The main production method is melting a mixture of quartz sand (SiO_2), soda (Na_2CO_3) and lime (CaO). The result is a chemical complex with the composition $\text{Na}_2\text{O} \cdot \text{CaO} \cdot 6\text{SiO}_2$.

The second is quartz glass. It is obtained by melting high-purity silica raw materials (usually quartzite, rock crystal). The chemical formula of the resulting substance is SiO_2 .

One of the auxiliary glass-forming is lead oxide PbO (from 10% in glass with a low lead content to 80% in lead crystals by weight, which is introduced in the form of a lead-red color. Lead is used Pb_3O_4 (heavy light red powder) or, as not commonly used, lead PbO (heavy dark yellow powder).

Nowadays, glass materials have been developed for a wide range of applications, with such qualities inherent initially as transparency, reflectivity, resistance to aggressive media and its synthesized qualities - heat resistance, strength, bioactivity, controlled electrical conductivity, etc.

Glass is an amorphous isotropic material obtained by supercooling melts of non-metallic oxides and oxygen-free compounds. Materials prone to hypothermia and glass transition are mainly silicates, borates, phosphates. [2]

The structure of windshield glazing for aircraft can be triplex, pentoplex or polyplex as several layers of high-strength transparent glass with a transparent interlayer between them. The thickness of each layer is 1 – 25 mm, the total thickness

reaches 100 mm. The fully assembled structure weighs approximately 150 kg. This type of glazing helps to prevent instantaneous depressurization of the cab in the event of damage to the outer layer.

The technological process of creating glass consists of preparing raw materials, mixing them and preparing a homogeneous mixture, melting, molding and annealing the glass. In some cases, chemical, mechanical and thermal treatment of molded products is required. A characteristic feature of glass technology is the commonality of methods for preparing raw materials, composing a charge and making glass for various industries. This circumstance allows us to consider the general patterns of the flow of pollutants into the environment using the example of almost any typical enterprise in the industry. Glass melting is carried out at a temperature of about 1400 – 1450°C, clarification and homogenization - at 1500°C, cooling - at 1200°C. At these temperatures, there is an intense emission of charge components, which with exhaust gases enter the atmospheric air.

Modern glass production is characterized by significant emissions of pollutants into the atmosphere. For example, a glass factory producing 200 tons of glass per day emits up to 5 tons of pollutants into the atmosphere per year, of which gaseous compounds account for 75-80%. The main pollutants in production are inorganic dust, aluminum oxide, sodium carbonate, sodium sulfate, as well as gaseous compounds such as oxides of nitrogen, carbon, sulfur, etc.

Emissions depend on the capacity of the glass furnaces. If in previous years their productivity was 60-90 tons per day, then the designed furnaces currently have a capacity of 200-300 tons per day or more. Moreover, increasing productivity is not always accompanied by the introduction of the latest technologies and the adoption of appropriate environmental protection measures.

The compound workshops of glass factories are dusty due to the unsatisfactory design and insufficient tightness of the equipment, the lack of shelters, and ineffective aspiration. In the areas of drying and sifting of quartz sand, dust content ranges from 10 to 100 mg/m; the bulk of the particles are less than 5 microns in size. A similar situation is observed in the areas of crushing and mixing of

components, where, in addition to the content of silicate particles, dust is characterized by significant alkalinity (up to 25%).

An additional source of emissions of pollutants into the atmosphere is the aeration lanterns of glass production workshops. Due to hygiene requirements, aeration lanterns carry out the function of removing excess heat and should not be a source of emission of pollutants. This means that all equipment in the workshop that emits pollutants must be supplied with systems for removing and cleaning emissions (refueling, glass production on glass-forming machines).

Suspended substances (dust) are emitted through aeration lanterns, the concentration of which is 1.5 - 2 mg/m³ (up to 1.5 tons per year). The following substances are emitted from feeders and glass-forming machines into the air of the working area and through aeration lanterns: carbon monoxide, propenal (acrolein), soot, oil products. As an example, the table 5.1 provides information on the gross emissions of pollutants into the atmosphere during glass melting in modern glass-making furnaces.

When calculating emissions from glass furnaces, it is necessary to use reliable measurement results – the results of calculation by balance methods, taking into account the exact volumes of waste gases. Special indicators can also be used. Methods for calculating emissions from boiler houses and other gas combustion devices are not used to calculate emissions from glass furnaces, since they give results that are dozens of times underestimated and not confirmed in practice.

Considering that in the atmosphere (at the exit from the chimney), nitrogen oxide is converted into dioxide by one of the reactions:

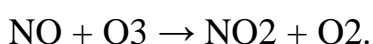

The greatest pollution of the atmosphere from glass furnaces (up to 80% and more) is produced precisely by nitrogen oxides (NO_x): nitrogen monoxide (NO) and nitrogen dioxide (NO₂). In large cities, where NO_x emissions are already exceeding the norm, the possibility of locating a glass factory must be coordinated at the design stage.

Table 5.1 - Average data on gross emissions of pollutants

Tones per day	Suspended substances (dust)	Nitrogen dioxide	Nitrogen monoxide	Sulfurous anhydride	Carbon monoxide
270	75	30	450	60	100
300	90	40	480	70	100
350	150	60	500	120	150

The noise factor also belongs to the environmental performance of the production. The main requirement is compliance with the values of 45-55 dBA in the residential area.

Important problems requiring constant attention and rational solutions are also the protection of water resources, the placement and disposal of industrial waste. Development projects for the production of glass containers should provide for local treatment facilities for pollutants, such as oil products, suspended surfactants, etc., as well as circulating water supply systems.

Glass is characterized as a non-hazardous waste, but the material is practically non-degradable. It will take about 1000 years for a typical glass bottle to decompose completely. It is also worth noting the excessive consumption and gradual depletion of natural resources as glass production belongs to the mineral processing industry.

5.2 Improvement from the impact

Work in the field of environmental protection can be subdivided as follows: cleaning and neutralization of harmful technological emissions and waste; rational use of industrial waste; development and implementation of rational technological processes.

Air pollution is tackled in a number of ways. According to sanitary design standards, industrial enterprises emitting harmful emissions are separated from settlements by sanitary protection zones.

Objects, their individual buildings and structures with technological processes that are sources of industrial hazards are divided by power, operational conditions, concentration of objects in the limited area, nature and amount of toxic and odorous substances released into the atmosphere, creating noise, vibration and other harmful physical factors. To reduce this negative impact on the environment and human health, the following minimum sizes of sanitary protection zones have been established:

- first class enterprise – 2000 m
- second class enterprise – 1000 m
- third class enterprise – 500 m
- fourth class enterprise – 300 m
- enterprise of the fifth class – 100 m

Sanitary protection zone is the territory between the boundaries of the industrial site, warehouses for open and closed storage of materials and reagents that can be sources of chemical, biological and physical impact on the environment and human health. Factories producing glass products are classified as the fifth class.

Despite its long decomposition period, glass is an environmentally friendly, fully recyclable material that offers great environmental benefits. For example: helps to mitigate the effects of climate change and conserves valuable natural resources. This material is also highly regarded in many applications for its inert nature and its contribution to human health and well-being.

Glass helps to save energy in many applications. This is most evident in the case of insulating glass for windows and facades, but also for lesser known products such as lightweight fiberglass reinforcement used in automobiles, aviation and other forms of transportation to reduce vehicle weight and fuel consumption.

Glass is also used to generate renewable energy through solar thermal and photovoltaic applications and wind turbines, which benefit greatly from lightweight fiberglass reinforced.

Since glass is a resource-saving material, it is made from abundant natural raw materials such as sand and glass waste (cullet). Recycling glass saves a significant amount of raw materials. Recycling glass also helps to save energy as the cullet melts at a lower temperature than the raw material. Consequently, the melting process requires less energy.

In other glass manufacturing sectors, considerable efforts are made to recycle glass after use, although each sector has its own characteristics and quality requirements. The amount of solid waste generated in the glass industry during production is extremely low in the glass industry, since almost all glass waste (cullet) is immediately recycled and sent back to the furnaces as raw materials.

In glass melting, the most important is the cleaning of waste gases from glass melting furnaces. Damp or wet methods are used to clean the exhaust gases. Sometimes special electrostatic precipitators are used to remove dust from exhaust gases. An example of an individual gas cleaning equipment is shown in Figure 5.1. The slag formed during the operation of the dust collector is sent to the settling tank, and the clarified water is sent to the supply tank for reuse. The experience of using dust collectors at factories has shown their high efficiency: the degree of cleaning is on average 97 - 99%. After cleaning, the concentration of dust in the flue gases of glass furnaces does not exceed the standard values.

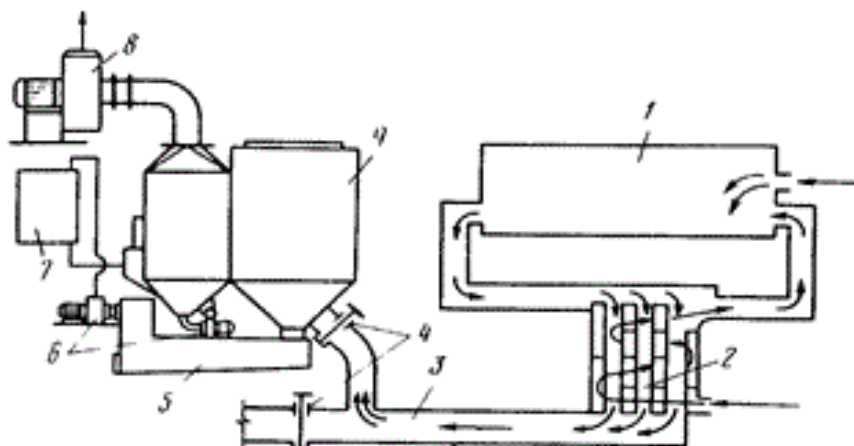

Figure 5.1 – Technological scheme of waste treatment glass furnace gases

1 - oven; 2 - recuperator (regenerator); 3 - chimney; 4 – gate; 5 – settling tank; 6 - pump; 7 - reuse reservoir; 8 - fan; 9 - PVT dust collector

For air purification in confined spaces and local areas of the formation of harmful emissions (processing of metals, polymers, natural stone, applying powder dyes, welding, soldering, grinding wood, etc.), cartridge filters are offered with manual and automatic regeneration of filter elements without stopping the working cycle. The cleaning efficiency in such filters is at least 99.9%. The productivity of the plants is 1000 – 20000 m^2 /hour.

Also to reduce emissions (pollutants) into the atmosphere from the production of glass containers, it is necessary to introduce advanced technologies. In particular, new devices for burning fuel, as reducing emissions only through gas and dust collection is uneconomical and does not reach the goal.

Conclusion of the part 5

Industrial emissions are the main source of air pollution. Among aviation materials, glass production is more environmentally friendly than ferrous and non-ferrous metals. When developing new or optimizing existing glass production technologies, it is necessary to solve the following problems of industrial ecology:

1. Development of environmentally friendly types of fuel, oxidizer or fundamentally new sources of thermal energy, allowing to minimize or eliminate toxic emissions.
2. Development of waste-free or low-waste glass production technologies that produce the final product with minimal or zero waste (emissions).
3. Creation of new types of equipment and technological processes that ensure the comprehensive and rational use of raw materials and fuel and energy resources.
4. Creation of technology for utilization of production wastes that form secondary material resources.

5. Development of special means of protecting the air from dust and gas emissions of harmful substances and thermal pollution.

6. Modernization of existing equipment and technological processes taking into account the requirements of industrial ecology.

With proper observance of the requirements of ecology and environmental protection, it is possible to minimize the negative impact.

GENERAL CONCLUSION

Glasses are widely used as a structural material. The requirements for their mechanical characteristics served as an impetus for the development of materials science and the creation of new materials based on them. A variety of types of glass allows you to select the required material for the parameters of any aircraft design. There are three main types of glass used in aviation: silicate, organic and polycarbonate.

Today there are a large number of different methods for assessing the mechanical characteristics of glass, as well as their resistance to destruction. All of these methods are based on different principles and are quite difficult to implement. Therefore, the determination of their mechanical characteristics, as well as the development of methods for their assessment is an urgent task.

A method of scratching the surface of the glass under study under constant load and on short tracks has been proposed and tested. In the course of the experiments, a significant influence of the medium on the process of glass destruction was found. The wide range of loads at which cracks occur is due to the influence of ambient humidity on glass damage during scratching.

In the compound departments of glass production, hygiene measures should first of all be aimed at combating with the main harmful factor - dust. The most successful dedusting of air in composite and ceramic compartments is possible only with complete mechanization of the entire production process, ensuring the tightness of the equipment, its shelters and transport routes, as well as with the mandatory collection and removal of dust in places of its formation.

Industrial emissions are the main source of air pollution. Among aviation materials, glass production is more environmentally friendly than ferrous and non-ferrous metals. When developing new or optimizing existing glass production technologies, it is necessary to solve the following problems of industrial ecology

References

1. Nurhaniza, M., Ariffin, M. K. A., Ali, A., Mustapha, F., Noraini, A. W. Finite element analysis of composites materials for aerospace applications
2. Boccaccini, A. Glass and glass-ceramic matrix composite materials.
3. Tantra R., Nanomaterial Characterization.
4. Ceramics and Glass in the Aerospace Industry Веб сайт. URL: <https://ceramics.org/about/what-are-engineered-ceramics-and-glass/ceramics-and-glass-in-the-aerospace-industry>
5. DSIAC Technical Inquiry (TI) Response Report, Department of Defense (DoD) and Commercial Aircraft Transparency Construction, Materials, and Applications
6. D.K. Rehbein, R.B. Thompson, O. Buck Crack, Length Determination by Ultrasonic Methods
7. Закон України №13 “Про охорону праці”.
8. ДСН 3.3.6.042-99 Санітарні норми мікроклімату виробничих приміщень.
9. ДСН 3.3.6.037-99 Санітарні норми виробничого шуму, ультразвуку та
10. інфразвуку.
11. «Гігієнічна класифікація праці за показниками шкідливості та небезпечності факторів виробничого середовища, важкості та напруженості трудового процесу» Веб сайт. URL: <http://zakon2.rada.gov.ua/laws/show/z0472-14>
12. НАПБ А 01.001-14 Правила пожежної безпеки в Україні
13. Анализ загрязнения окружающей среды выбросами стекольной промышленности. Веб сайт. URL: <https://cyberleninka.ru/article/n/analiz-zagryazneniya-okruzhayushey-sredy-vybrosami-stekolnoy-promyshlennosti/viewer>
14. Sustainability & the Environment. Веб сайт. URL: <https://www.glassallianceeurope.eu/en/environment>

15. Экологические проблемы производства стеклотары. Веб сайт. URL:
<https://msd.com.ua/sovremennoe-steklotarnoe-proizvodstvo/ekologicheskie-problemy-proizvodstva-stekltary/>
16. Экологические проблемы стекольного производства. Веб сайт. URL:
<https://works.doklad.ru/view/WIU0NV0yihY.html>