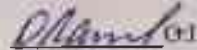

MINISTRY OF EDUCATION AND SCIENCE OF UKRAINE  
NATIONAL AVIATION UNIVERSITY  
FACULTY OF ARCHITECTURE, CIVIL ENGINEERING AND DESIGN  
COMPUTER TECHNOLOGIES OF AIRPORT CONSTRUCTION AND  
RECONSTRUCTION DEPARTMENT

TO ADMIT TO GUARD

Head of the Department

 Olexandr Lapenko  
- 01 - 08 2022

## BACHELOR THESIS

(EXPLANATORY NOTE)

SPECIALTY 192 «BUILDING AND CIVIL ENGINEERING»

Educational and professional program: «Industrial and civil engineering»

**Theme: Reconstruction of the office and hotel complex in Zaporizhzhia**

**Performed by:** \_\_\_\_\_ Fatima-Zahrae Mounir

**Thesis Advisor:** \_\_\_\_\_ Oleksandr Horb

**Design rule check:** \_\_\_\_\_  O. Rodchenko

Kyiv 2022

МІНІСТЕРСТВО ОСВІТИ І НАУКИ УКРАЇНИ  
НАЦІОНАЛЬНИЙ АвіАЦІЙНИЙ УНІВЕРСИТЕТ  
ФАКУЛЬТЕТ АРХІТЕКТУРИ, БУДІВНИЦТВА ТА ДИЗАЙНУ  
КАФЕДРА КОМП'ЮТЕРНИХ ТЕХНОЛОГІЙ БУДІВНИЦТВА ТА  
РЕКОНСТРУКЦІЇ АЕРОПОРТІВ

ДОПУСТИТИ ДО ЗАХИСТУ

Завідувач випускової кафедри

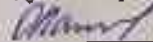
 О. Лапенко

" 08 " 10 2022 р.

## ДИПЛОМНА РОБОТА

(ПОЯСНЮВАЛЬНА ЗАПИСКА)

ВИПУСНИКА ОСВІТНЬОГО СТУПЕНЯ БАКАЛАВРА  
ЗА СПЕЦІАЛЬНІСТЮ 192 «БУДІВНИЦТВО ТА ЦИВІЛЬНА ІНЖЕНЕРІЯ»  
ОСВІТНЬО-ПРОФЕСІЙНА ПРОГРАМА  
«ПРОМИСЛОВЕ І ЦИВІЛЬНЕ БУДІВНИЦТВО»

Тема: «Реконструкція офісно-готельного комплексу у м. Запоріжжя»

Виконавець: студент ЦБ-406 Ба гр. МУНІР Фатіма-Захра  
(студент, група, прізвище, ім'я, по батькові)

Керівник: к.т.н., Горб Олександр Григорович  
(науковий ступінь, звання, прізвище, ім'я, по батькові)

Нормоконтролер:



Родченко О.В.  
(ПІБ)

Київ 2022

## НАЦІОНАЛЬНИЙ АВІАЦІЙНИЙ УНІВЕРСИТЕТ

Факультет архітектури, будівництва та дизайну

Кафедра комп'ютерних технологій будівництва та реконструкції аеропортів

Спеціальність: 192 «Будівництво та цивільна інженерія»

Освітньо-професійна програма: «Промислове і цивільне будівництво»

ЗАТВЕРДЖУЮ

Завідувач кафедри

 О.А. Лаленко

« 13 » 104 2022 р.

### ЗАВДАННЯ на виконання дипломної роботи

МУНІР Фатіма-Захра

(П.І.Б. випускника)

1. Тема роботи «Реконструкція офісно-готельного комплексу у м. Запоріжжя» затверджена наказом ректора від «13» квітня 2022р. № 379/ст.

2. Термін виконання роботи: з «23» травня 2022р. по «19» червня 2022р.

3. Вихідні дані роботи: план та переріз офісно-готельного комплексу, навантаження відповідно до ДБН В.1.2-2:2006 «Навантаження та впливи».

4. Зміст пояснювальної записки:

Вступ, аналітичний огляд, архітектурно-планувальна частина, розрахунково-конструктивна частина, технологічно-організаційна частина, висновки, список використаних джерел.





5. Перелік обов'язкового ілюстративного матеріалу: таблиці, рисунки, діаграми, графіки не менше 4-х креслень та 4-х слайдів:

-фасади, план типового поверху, експлікації

- креслення конструкції, специфікації елементів

-технологічно-організаційні схеми виконання основних будівельних процесів

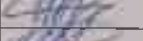
## 6. Календарний план-графік

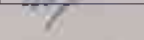
№ з/п	Завдання	Термін виконання	Підпис керівника
1.	Аналітичний огляд	13.05.22-14.05.22	
2.	Архітектурно-будівельний розділ	16.05.22-20.05.22	
3.	Розрахунково-конструктивний розділ	23.05.22-02.06.22	
4.	Технологічно-організаційна частина	03.06.22-04.06.22	
5.	Вступ. Висновки. Список використаних джерел.	06.06.22-07.06.22	
6.	Підготовка доповіді та презентації	08.06.22-11.06.22	

8. Дата видачі завдання: «13» травня 2022 р.

Керівник дипломної роботи:

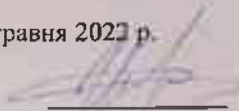

Горб О.Г.

Завдання прийняв до виконання:



МУНІР Фатіма-Захра

# Content

<b>1. Introduction</b> .....	3
1.1. Reasons for the object reconstruction .....	3
1.2. Characteristics of the area and construction site .....	5
1.3. Description of the projected object technology .....	6
1.4. Technical and economic substantiation of the volumetric planning solution .....	8
<b>2. Architectural and construction chapter</b> .....	9
2.1. Master Plan .....	9
2.2. Space-planning solution .....	10
2.3. Constructive solution.....	11
2.4. Exterior and interior decoration.....	12
2.5. Thermal calculation of the cover.....	14
2.6. Thermal calculation of the wall.....	16
<b>3. Calculation and construction section</b> .....	18
3.1. Calculation of decking .....	18
3.2. Calculation of the superstructure floor column .....	25
<b>4. Basics and foundations</b> .....	32
4.1. Evaluation of engineering and geological conditions .....	32
4.2. Calculation of foundations .....	32
<b>5. Construction technology</b> .....	38
5.1. Works of the preparatory period of the superstructure .....	38
5.2. Roofing works.....	43
5.3. Flooring and finishing works.....	45
5.4. Environmental protection.....	47
<b>References</b> .....	51

					<i>EN 406-BA</i>			
<i>Ch.</i>	<i>Sh.</i>	<i>No doc.</i>	<i>Signature</i>	<i>Data</i>	<i>Reconstruction of the office and hotel complex in Zaporizhzhia</i>			
Developer		<i>Fatima-Z. M.</i>				<i>Let.</i>	<i>Sheet</i>	<i>Sheets</i>
Supervisor		<i>Horb O.</i>						
N. Control						<i>National Aviation University</i>		
Approved		<i>Lapenko O.</i>						

# 1. Introduction

## 1.1 Reasons for the object reconstruction

Today, the hotel business is one of the most promising and rapidly developing industries, bringing multimillion-dollar profits around the world. The hotel business as a sub-sector of tourism carries a huge potential for the global market, capable of bringing a steady income to the budget of the country. Every year the number of hotels in our country and abroad grows.

Over the past few years, hotels have become a leader in specialized programs and marketing research. What is this category of hotels and what is the reason for their popularity? To date, there are no strictly defined international or national standards, classifying means of accommodation by their volume. In practice, hotels are divided into four large categories: small hotels (up to 150 rooms), medium hotels (from 151 to 300 rooms), large hotels (from 301 to 600 rooms) and giant hotels (over 600 rooms).

Now in Ukraine a small hotel is a hotel with 10 to 100 rooms (a place of accommodation that does not have 10 rooms is not considered a hotel in Ukraine). Small hotels occupy a very modest place in the total number of hotels operating today: they account for slightly over 4% in Kiev. Mass tourism that used to dictate the rules of the game in hotel-tourist services left uniformity of hotel product.

Interest to small forms of hotel business organization is evident not only in Ukraine. It is determined by changes in behavior of main consumers of hotel services, which are known to be tourists. Small hotels are easier to adapt to each client, create an atmosphere of home, which does not exclude bringing national coloring to life of guests. In addition, small hotels tend to apply a more flexible system of discounts and cost the customer less than large hotels of a similar class. All this allows these forms of hotel business to take a strong position in the market of different countries, including Ukraine. Thus, the appearance of small hotels is a response to the demand of tourists for small forms and home

	Name	Signature	Date	<i>EN 406-BA</i>	Sheet
Developer	Fatima-Z. M.				3
Sup-sor	Horb O.				

comfort.

The main customers of small hotels are middle class business people, whose stay in the city does not require prestigious international hotels. As a rule, these customers need moderate comfort, good food, cleanliness and safety, and they find all this in small hotels. Added to that are reasonable prices and a special cozy atmosphere that is difficult to create in hotel giants. Small hotels have another advantage over large hotels: they bring tourists as close to the objects of interest as possible because it is easier to integrate them into the historical environment of the city.

However, having small capacity, a hotel, accordingly, has low sales volume. Besides, the share of variable costs increases significantly in the turnover structure of such a hotel because with the existing volume of purchases it is difficult for it to achieve optimal prices for detergents, laundry services, etc. Small hotels have a lot of difficulties with staffing, as their staff must be multi-skilled for the hotel to remain profitable. Thus, it is difficult for a small hotel to increase efficiency by applying cost reduction method. On the other hand, under the pressure of competition, it cannot increase the price of accommodation. To reduce variable costs, a small hotel has only one way to do so - to team up with its peers in order to make bulk purchases at reasonable prices, conduct joint advertising campaigns, market research and use other ways to reduce the expenditure side of the budget. Another way to solve the problems of small hotels is, oddly enough, to increase their capacity. The example of the small hotel "Perlina" in Zaporozhye, which had 30 rooms after its opening in 2008, shows this. At the end of 2016, "Perlina" opened a second building with 90 beds, with a conference hall, fitness center and other attributes of an urban business hotel. Other small hotels are also nurturing expansion plans.

Thus, small hotels segment is not very stable in spite of the fact that a certain part of tourist flow prefers it to all others. In such conditions the development of small forms of entrepreneurship, to which small hotels can be safely referred, requires directed support from the central or local authorities.

	Name	Signature	Date	<b>EN 406-BA</b>	Sheet
Developer	Fatima-Z. M.				4
Sup-sor	Horb O.				

Reconstruction (superstructure of the fourth floor) of the hotel complex is associated with the prospect of development of the hotel complex (according to the customer's request) increasing the area for hotel rooms in order to obtain additional profits.

## 1.2. Characteristics of the area and construction site

The building is located in Zaporizhzhia, Zaporizhzhia region.

The average temperature of the coldest day and the coldest five-day period with a security of 2.92 is taken from the table "Outdoor temperature":

$$t_{h.c.} = -29 \text{ }^{\circ}\text{C} \qquad t_{n.c.} = -23 \text{ }^{\circ}\text{C}$$

Depth of soil freezing – 0,9 m.

Area by weight of snow cover – II.

Area of high-speed wind pressure – II.

The area is not seismic.

The degree of aggressive action of the environment on above-ground metal and reinforced concrete structures inside the building and in the open air is a weakly aggressive environment.

The designed building belongs to the III<sup>a</sup> degree of building fire resistance.

The planning of the complex is accepted in accordance with the technical and economic requirements.

Soils are represented by the following layers: anthropogenic (bulk) soils, represented by pebbles, sand and cover the site layer up to 1.0 m.

Below in the interval from 1 to 2.8 m sandy clay of solid consistence, from 2.8 to 3.4 m sand of dusty consistence, from 3.4 to 4.6 m sandy clay of solid consistence

From the depth of 4.6 m, pebble-like soil with sandy aggregate is underlain.

Groundwater is found at the depth of 5.5 m. Significant change of groundwater level during the long-term period is not observed due to drainage

	Name	Signature	Date	<b>EN 406-BA</b>	Sheet
Developer	Fatima-Z. M.				<b>5</b>
Sup-sor	Horb O.				



canals operation. At termination of water pumping from drainage canals groundwater level can rise within 0,5-1 m.

Permanent water supply sources and networks, central sewage system are used during reconstruction of the object.

Local materials such as crushed stone, sand are used to perform concrete works. Since the reconstruction is carried out in a residential area, there is no need for special wiring of electricity and telephone service.

### **1.3. Description of the projected object technology**

The existing building of the hotel to be reconstructed by adding another floor is located on 2 Klubna Street. The building of the hotel complex is three-storey, brick, with a pitched roof. On the first floor there are two saunas, a bar and a billiard room for two game tables. Both the hotel guests and the visitors can use them.

Sauna (two sauna rooms and ancillary rooms):

The number of employees per shift - 4 people (administrator, castellan, sellers of related goods);

The number of visitors per hour - 3 people in the sauna;

Working hours - 09-00 - 24-00

Sauna visitors can enter the lobby or from the street through the vestibule or through the hotel lobby. After ordering and paying for seats (if necessary in the lobby you can buy goods for visiting the sauna), visitors go to the dressing room where you can remove outerwear, then to the rest room. This room has benches for relaxing after the steam room, a dining table. If visitors wish it is possible to allocate a training zone. The bathroom adjoins the rest room. From the shower room and the pool area you can enter the steam room. The dry heat bath (sauna) is designed for taking hot, dry, air baths combined with subsequent alternating cooling under the shower and in the pool. The dry heat chamber is heated with an electric fireplace, which heats the ambient air by means of

	Name	Signature	Date	<b>EN 406-BA</b>	Sheet
Developer	Fatima-Z. M.				6
Sup-sor	Horb O.				

electric heaters, as well as cobblestone stones laid on top. The temperature of the upper zone is 95-130 C. The supply of fresh air is carried out through the slot under the door and a special air inlet opening under the electric fireplace. Air is removed through the longitudinal slot in the lining of the back wall of the chamber behind the shelves into the exhaust box. The air inflow is natural, from the neighboring rooms, the hood with mechanical inducement.

Cooling down after taking a warming session is done in the shower or pool area. After the session, you need to rest in a room with wooden beds.

Used laundry is stored in the dirty laundry room and sent to the laundry when accumulated. On arrival from the laundry, clean laundry is stored in the laundry room and given out through the ironing room.

Snack bar and billiard room:

Number of employees - 4 people.

Number of seats - 20.

Working hours - 6-00 - 24-00

Visitors passing through the vestibule, enter the hall, from which you can go to the snack bar and auxiliary facilities, billiard room, bathrooms for visitors through the checkroom to the heating unit and the hotel rooms of the 2nd and 3rd floor through the hall of stairs.

The snack bar premises consist of a dining room for 12 people and a bar counter for 8 people, a staff room, a washing room and a kitchen. The snack bar operates on half-finished products, which are delivered daily in small portions and packed in refrigerators. A microwave oven installed in the bar area of the dining room is used for cooking and heating food. Cutting ready-made food and serving it is done in the kitchen workshop. The washing room is equipped with a hand wash and a 2-part dishwasher, as well as drying shelves. Visitors use disposable dishes. Servicing is done by waiters and used dishes are removed to special bins and then to garbage cans in the economic area of the complex.

There are two gaming tables and seats for spectators in the billiard room. Shelves for billiard equipment are located near the tables.

	Name	Signature	Date	<b>EN 406-BA</b>	Sheet
Developer	Fatima-Z. M.				<b>7</b>
Sup-sor	Horb O.				

The heating unit of the complex is placed behind the dressing room. The transit heating main (according to the issued technical specifications) is isolated from the premises by means of a corridor which makes possible operational servicing. From the corridor there is an exit directly to the street.

From the lobby, visitors can get to the bathrooms (men's and women's) on the type of sanitary passages.

Hotel:

Number of employees per shift - 4 people

Number of seats - 44

Working hours - 24 hours a day.

From the hall on the stairs, visitors get to the hall of registration and registration of the documents, after that they are settled in the rooms. Rooms are designed 1-2-3 beds, with dressing rooms, living rooms, bedrooms and bathrooms. Each room has a refrigerator, TV and telephone. On the floors are rooms: staff, household, room cleaning clothes, household and household tools.

## **1.4. Technical and economic substantiation of the volumetric planning solution**

In developing the volume-planning solution of the reconstructed building were considered two options for the structural scheme:

- 1) brick with incomplete frame;
- 2) with metal frame.

When comparing them, you can see that the metal frame is the most profitable for the following reasons:

- significant reduction in the load on the existing columns and building foundations;
- increasing retail space through the use of smaller structures.

Metal structures are traditionally used in construction, providing high strength and reliability of buildings, and the theory of their calculation is by far

	Name	Signature	Data	<b>EN 406-BA</b>	Sheet
Developer	Fatima-Z. M.				8
Sup-sor	Horb O.				

the most elaborated. In addition to these advantages, another of their undoubted advantages is their low dead weight. It is this circumstance contributes to the high efficiency of their use in the reconstruction of existing buildings.

## 2. Architectural and construction chapter

### 2.1. Master Plan

Reconstructed hotel complex is located at Zaporizhia, Klubna Street, 2 and has the following technical and economic indicators (Table 2.1):

Table 2.1. Technical and economic indicators of the existing building

№	Name	Unit	Number
1	building volume	m <sup>3</sup>	5574,9
2	building area	m <sup>2</sup>	586,80
3	total area	m <sup>2</sup>	1588,3

The area adjacent to the hotel provides pedestrian paths and sidewalks with asphalt surface, area for temporary parking. Along the sidewalk there are lights.

Taking into account the superstructure, the building will have the following technical and economic indicators (Table 2.2):

Table 2.2. Technical and economic indicators of the building superstructure

№	Name	Unit	Number
1	building volume	m <sup>3</sup>	1858,3
2	building area	m <sup>2</sup>	586,80
3	total area	m <sup>2</sup>	529,43

Construction volume increases by 33.3%, the total area increases by 1.3 times.

	Name	Signature	Date	<b>EN 406-BA</b>	Sheet
Developer	Fatima-Z. M.				9
Sup-sor	Horb O.				

## 2.2. Space-planning solution

### Existing building

The building of the hotel "Perlyna" in order to increase hotel rooms or placement of office space will be reconstructed by adding one floor of the building.

On the first floor there are two saunas, a bar and a billiard room with two gaming tables. They can be used by the occupants of the hotel as well as by the visitors.

The space-planning solution of the 1st floor of the complex includes two main groups of premises: a sauna and a bar with a billiard room.

The structure of the premises of the sauna includes:

- tambour;
- an entrance hall with an administrator's room, waiting area, and related trade area;
- electrical control room of the complex;
- electrical switchboard of the complex; -utility and service rooms;
- sauna premises.

The second group of premises includes:

- tambour;
- lobby with bathrooms, checkroom and waiting area;
- a heating unit with a transit channel of heating mains;
- billiard room for two gaming tables;
- refreshment bar with auxiliary premises.

Both groups of rooms have isolated entrances. The connecting one is the lobby with stairs leading to the 2nd and 3rd floors, to the hotel rooms. In the hall of the second floor is the registration desk. Here are also cleaning and ironing rooms, storage rooms for clean and dirty laundry. Restrooms for staff are located on each floor. The staff room and inventory room are on the third floor. Hotel rooms on the 2nd and 3rd floors have practically the same layout.

	Name	Signature	Data	<b>EN 406-BA</b>	Sheet
Developer	Fatima-Z. M.				10
Sup-sor	Horb O.				

Rooms are designed to stay 1-2-3 people, suites and junior suites. Each room has a telephone, refrigerator and TV.

Corridors and halls of the hotel are lit, fire evacuation is carried out through the central staircase and the external staircase.

### 2.3. Constructive solution

The existing building of the hotel with an incomplete frame, has a rectangular shape in terms of the size of the axes 16.79×31.5 meters. The building is three-storey without a basement.

The constructive scheme of the building - frame. The frame consists of metal columns, supported by brick load-bearing walls and columns.

#### Types of structural elements of the existing building

Foundations - pile (piles C 6-30)

Columns - brick, rectangular cross-section.

Crossbar - reinforced concrete, rectangular cross-section, height 500 mm.

Floor slabs - prefabricated reinforced concrete, size 1200×6300 mm, 1500×6300 mm.

The walls - the brick external load-bearing walls with a thickness of 640 mm, 120 mm thick partitions.

The roof - pitched non-exploitation with external drainage system. The roof is made of wooden rafters of pine wood II grade.

#### Description of the structural elements of the superstructure

Columns - metal of BCТ3CП steel grade, in the form of a rolled I-beam I 20 B1.

Beam - metal of BCТ3CП steel grade, in the form of a rolled I-beam.

Decking beams - metallic steel grade BCТ3CП, in the form of a rolled I-beam.

Roofing - pitched.

	Name	Signature	Date	<b>EN 406-BA</b>	Sheet	
Developer	Fatima-Z. M.				<b>EN 406-BA</b>	11
Sup-sor	Horb O.					

Decking - profiled decking of H57-750-0.8 grade, length 3150 mm.

Insulation - mineral wool boards of increased rigidity on the argon-phosphate binder, laid in two layers.

Vapor barrier - one layer of ruberoid on bitumen mastic

Exterior walls - made of fire-resistant three-layer metal sandwich panels.

Sandwich panels are a three-layered structure of galvanized steel sheet with polymer coating and the middle insulating layer, bonded with a special polyurethane adhesive and designed for use as lightweight wall and roofing structures.

Fireproof three-layered metal sandwich panels with environmentally friendly mineral wool insulation is the most effective building envelopes.

The base of the panels is a core of the best high-performance insulation materials (non-combustible mineral wool slabs with perpendicularly oriented fibers based on basalt rocks). The thickness of this layer varies depending on the purpose and climatic conditions in which the product will be used.

Insulating mass is protected on both sides of the cladding (profiled galvanized and painted steel sheet) layers, which create, among other things, additional structural rigidity. Durable connection of the cladding and insulation provides high-quality adhesive.

Windows, doors - plastic.

## 2.4. Exterior and interior decoration

**The existing building:**

**Exterior finishes:**

Walls - brick, covered with terrazzite plaster.

Windows, doors – plastic.

Decorative elements of the entrance, canopies, skylights, fences - metal pipes, angles.

Stained glass – plastic.

	Name	Signature	Data	<i><b>EN 406-BA</b></i>	Sheet
Developer	Fatima-Z. M.				12
Sup-sor	Horb O.				

Visor bottom - metal siding.

Roofing - type "Ondulin".

**Interior finishing:**

Recreation room, dressing room: floors - boarded; ceilings - water-emulsion paint; walls - wood paneling.

Rooms with a wet mode: floors - ceramic tiles with the device traps, ceilings - painting, walls - glazed ceramic tiles to the entire height.

Hall, corridor: floors - ceramic granite, homogeneous coating; walls - decorative plaster and water-emulsion paint; ceilings - suspended Armstrong.

Storeroom rooms: floors - linoleum; ceilings and walls - water-emulsion paint.

Rooms and staff rooms: floors - carpeting (in the bedroom and living room), linoleum (hallway and subdivisions), ceramic tiles (bathroom), walls - wallpapering, in bathrooms - ceramic tiles, ceilings - water-emulsion paint;

Corridors: floors - homogeneous coating; walls - wallpaper or paint; ceilings - water-based paint.

**Superstructure floor:**

Наружные стены выполнены из огнестойких трехслойных металлических сэндвич-панелей

Interior finish consists of:

- plastering the surface of the walls, followed by their improved painting with oil compositions;

- Armstrong suspended ceilings

- facing of the metal columns with GFB sheets, to be painted with oil-based compositions.

- floors in the rooms and the corridor boarded on the logs, and - of linoleum, in the bathrooms - ceramic tiles.

	Name	Signature	Date	<i><b>EN 406-BA</b></i>	Sheet
Developer	Fatima-Z. M.				13
Sup-sor	Horb O.				



## 2.5. Thermal calculation of the cover

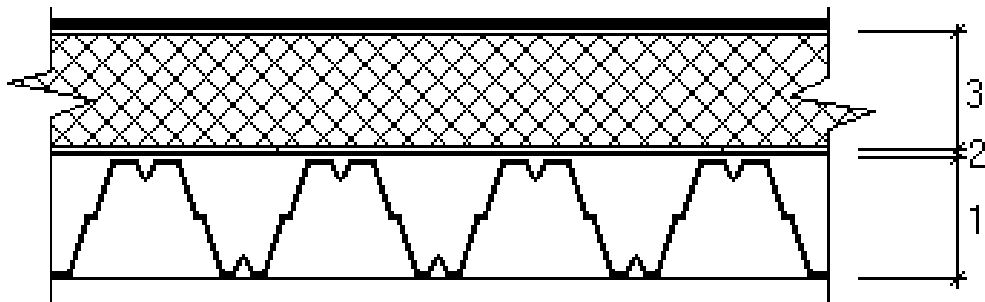

Fig. 2.1 Cutting along the cover plate:

1 - steel profiled sheeting, 2 - vapor barrier (1 layer of roofing felt), 3 - insulation

Determine the necessary thermal characteristics of the structural layers and summarize them in the table:

Table 2.3. Cover construction

Name	$\gamma_0$ , kg/m <sup>3</sup>	$\delta$ , m	$\lambda$ , Wt/(m*°C)	R, m <sup>2</sup> °C/Wt
Profiled decking H57-750-0,8	7850	$8 \cdot 10^{-4}$	58	$1,37 \cdot 10^{-5}$ *
Vapor barrier (1 layer of roofing felt)	600	0,01	0,17	0,059
Insulation (mineral wool stiffened plates)	200	X	0,07	

The required thermal resistance of the enclosing structure is determined from the condition of energy conservation.

We calculate for a public building, therefore, the relative humidity inside the room - normal,  $\varphi = 50\%$ , the temperature of the internal air:  $t_e = 18^\circ\text{C}$ .

The degree-days of the heating period is determined by the formula:

$$\Gamma\text{COII} = (t_e - t_{om.n}) * Z_{om.n} = (18 - (-9,7)) * 225 = 6232,5$$

The required heat transfer resistance of the enclosing structures is determined by the formula:

	Name	Signature	Data	<b>EN 406-BA</b>	Sheet
Developer	Fatima-Z. M.				14
Sup-sor	Horb O.				

$$R_o^{TP} = \frac{n(t_e - t_n)}{\Delta t^H \cdot \alpha_e} = \frac{1(18 + 40)}{5,5 \cdot 8,7} = 1,67$$

where  $n=1$  - coefficient, depending on the position of the outer surface of the enclosing structures in relation to the outside air;

$\Delta t^H = 5,5 \text{ }^\circ\text{C}$  – normative temperature difference between the internal air temperature and the temperature of the internal surface of the enclosing structure;

$\alpha_e = 8,7 \text{ Wt/(m}^\circ\text{C)}$  – heat transfer coefficient of the internal surface of the enclosing structures.

The heat transfer resistance of the enclosing structures is determined by interpolation:

$$R_o^{TP} = 3,08 \text{ m}^2 \text{ }^\circ\text{C/Wt}$$

$$\text{because } R_o^{TP} = 1,67 \text{ m}^2 \text{ }^\circ\text{C/Wt} < R_o^{TP} = 3,08 \text{ m}^2 \text{ }^\circ\text{C/Wt}$$

in the further calculation we take  $R_o^{TP} = 3,08 \text{ m}^2 \text{ }^\circ\text{C/Wt}$

Determine the required thickness of the insulation layer:

$$R_o = \frac{1}{\alpha_B} + R_K + \frac{1}{\alpha_H}, \text{ where}$$

$R_K$  — thermal resistance of the multilayer building envelope,  $\text{m}^2 \text{ }^\circ\text{C/Wt}$ ;

$\alpha_H = 23 \text{ Wt/(m}^\circ\text{C)}$  - heat transfer coefficient (for winter conditions) of the outer surface of the enclosing structure;

$$R_K = R_1 + R_2 + \dots + R_n + R_{B.II}, \text{ where}$$

$R_1, R_2, \dots, R_n$  — thermal resistances of individual layers of the building envelope;

$R_{B.II} = 0$  - thermal resistance of the closed air layer.

$$R = \frac{\delta}{\lambda}, \text{ where}$$

$\delta$  — layer thickness, m;

	Name	Signature	Data	<b>EN 406-BA</b>	Sheet
Developer	Fatima-Z. M.				15
Sup-sor	Horb O.				

$\lambda$  — design heat transfer coefficient of the layer material,  $Wt/(m^{\circ}C)$ ;

$$R_0 = \frac{1}{8.7} + 1,37 \cdot 10^{-5} + 0,059 + \frac{x}{0.07} + \frac{1}{23};$$

$$3,08 = 0,22 + \frac{x}{0.07}$$

$$x = 0,2$$

Take the thickness of the thermal insulation layer 200 mm.

Total heat transfer resistance of the coating:

$$R_0 = \frac{1}{8.7} + 1,37 \cdot 10^{-5} + 0,059 + \frac{0.2}{0,07} + \frac{1}{23} = 4.181 \text{ m}^2 \cdot ^{\circ}C/Wt.$$

$$R_0 = 3,17 \text{ m}^2 \cdot ^{\circ}C/Wt > R_{p_0} = 3,08 \text{ m}^2 \cdot ^{\circ}C/Wt$$

Therefore, the condition of resistance to heat transfer is satisfied.

## 2.6. Thermal calculation of the wall

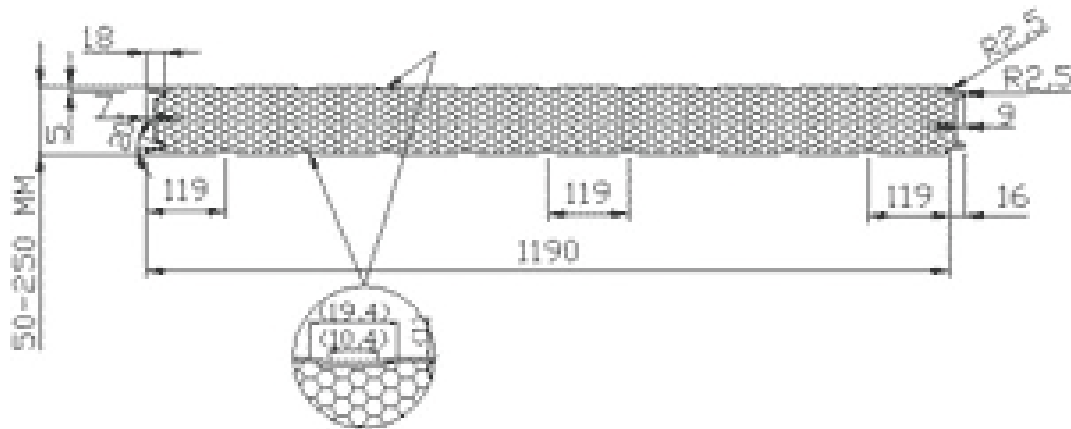

Fig. 2.2. Wall construction

Fire-resistant three-layer metal sandwich panels with environmentally friendly mineral wool insulation are the most efficient fencing structures.

The base of the panels is a core of highly efficient thermal insulation materials (noncombustible mineral wool boards with perpendicularly oriented fibers based on basalt rocks).

	Name	Signature	Data	<b>EN 406-BA</b>	Sheet
Developer	Fatima-Z. M.				16
Sup-sor	Horb O.				

Table 2.3. Wall construction

Name	$\gamma_o$ , kg/m <sup>3</sup>	$\delta$ , m	$\lambda$ , Wt/(m*°C)	R, m <sup>2</sup> °C/Wt
sandwich panel	105	150	0,047	3,18

The degree-days of the heating period is determined by the formula:

$$\Gamma\text{COII}=(t_g - t_{om.n}) * Z_{om.n.}=(18-(-9,7)) * 225=6232,5$$

The required heat transfer resistance of the enclosing structures is determined by the formula:

$$R_o^{TP} = \frac{n(t_g - t_n)}{\Delta t^H \cdot \alpha_g} = \frac{1(18+40)}{7 \cdot 8,7} = 0,95$$

where n=1 - coefficient, depending on the position of the outer surface of the enclosing structures in relation to the outside air;

$\Delta t^H = 7 \text{ }^\circ\text{C}$  – normative temperature difference between the internal air temperature and the temperature of the internal surface of the enclosing structure;

$\alpha_g=8,7 \text{ Wt}/(m^*\text{ }^\circ\text{C})$  – heat transfer coefficient of the internal surface of the enclosing structures.

The heat transfer resistance of the enclosing structures is determined by interpolation:

$$R_o^{mp}=3,08 \text{ m}^2 \text{ }^\circ\text{C}/\text{Wt}$$

The heat transfer resistance of the enclosing structure is determined by the formula:  $R_o=1/\alpha_B+R_K+1/\alpha_H$  ,

where  $\alpha_H = 23 \text{ Wt}/(m^*\text{ }^\circ\text{C})$  - heat transfer coefficient in winter conditions for the outer surface of the enclosing structure.

Take the thickness of the thermal insulation layer 150 mm.

$$R_o = \frac{1}{8.7} + 3,18 + \frac{1}{23} = 3,34 \text{ m}^2 \cdot \text{ }^\circ\text{C}/\text{Wt}.$$

$$R_o = 3,34 \text{ m}^2 \cdot \text{ }^\circ\text{C}/\text{Wt} > R_o^{mp} = 3,08 \text{ m}^2 \cdot \text{ }^\circ\text{C}/\text{Wt}$$

Therefore, the condition of resistance to heat transfer is satisfied.

	Name	Signature	Data	<b>EN 406-BA</b>	Sheet
Developer	Fatima-Z. M.				17
Sup-sor	Horb O.				

### 3. Calculation and construction section

#### 3.1. Calculation of decking

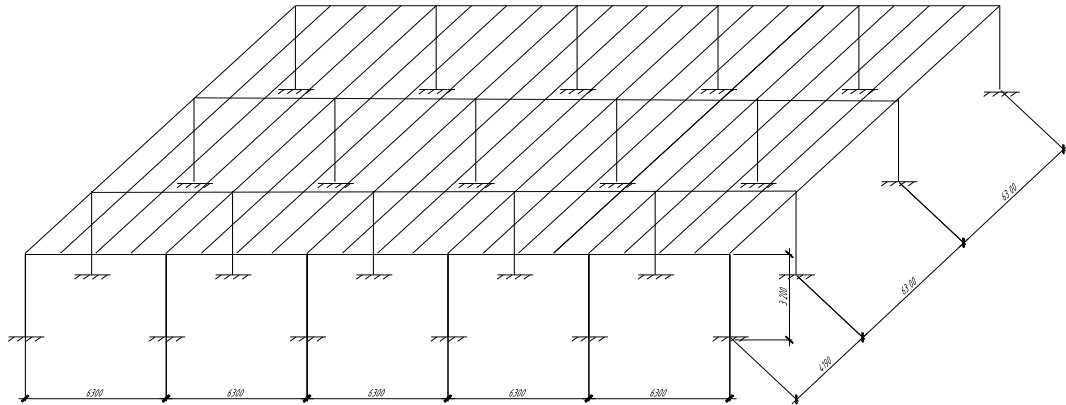

Fig. 3.1. Constructive scheme of the superstructure

Table 3.1 Collection of deck loads

Type of load	Normative load, kN/m <sup>2</sup>	Reliability coefficient by load, $\gamma_f$	Design load, kN/m <sup>2</sup>
1	2	3	4
Permanent :			
- Insulation (mineral wool slabs) : $\delta=0,19$ m, $\gamma = 200$ N/m <sup>3</sup> .	0,38	1,3	0,49
- Vapor barrier (1 layer of roofing felt):	0,05	1,3	0,065
- Own weight of the profiled flooring of the brand H57-750-0,8	0,098	1,05	0,104
<b>Total:</b>	<b>0,528</b>		<b>0,686</b>

Determine the design load:  $q_p = q^p \cdot a$ ,

$$q_p = 0,686 \cdot 0,75 = 0,515 \text{ kN/m}$$

where  $a=0,75$  m – floor width.

Determine the standard load capacity:  $q_H = q^H \cdot a$ ,

$$q_H = 0,528 \cdot 0,75 = 0,396 \text{ kN/m}$$

	Name	Signature	Data	<b>EN 406-BA</b>	Sheet
Developer	Fatima-Z. M.				18
Sup-sor	Horb O.				

## Static calculation

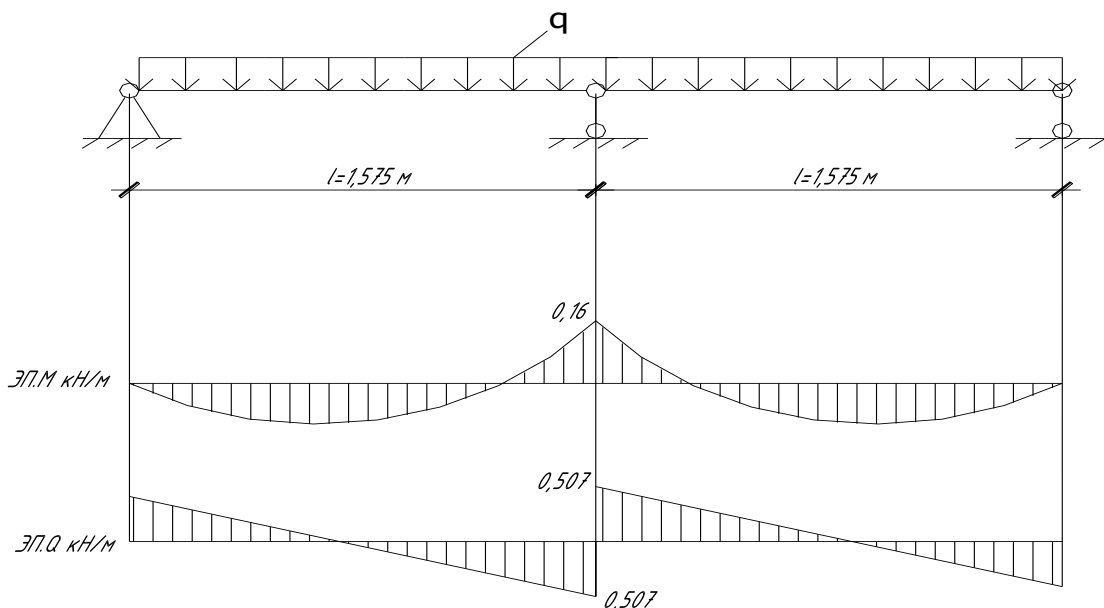

Fig. 3.2. Calculation scheme of the decking.

$$M_{max} = q_p l^2 / 8 = 0,515 \cdot 1,575^2 / 8 = 0,16 \text{ kNm};$$

$$Q_{max} = 0,625 q_p l = 0,625 \cdot 0,515 \cdot 1,575 = 0,507 \text{ kN}.$$

### Selecting the profile type

**We accept decking of the brand H57-750-0,8:**

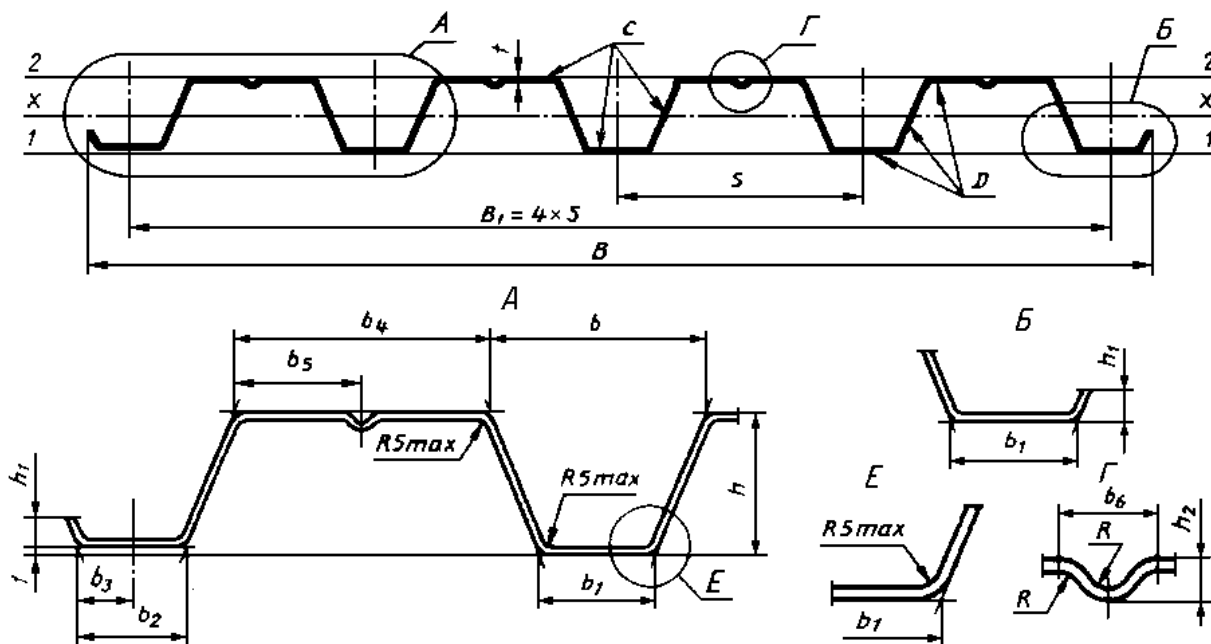

Fig. 3.3. Section of profiled sheeting

	Name	Signature	Data		Sheet
Developer	Fatima-Z. M.			<b>EN 406-BA</b>	19
Sup-sor	Horb O.				

Geometric characteristics of the decking:

compressed narrow and wide shelves:

$$I_x=61,2 \text{ cm}^4; \quad W_x=17,9 \text{ cm}^3.$$

### Verification according to the first group of limit states

Calculation of the strength of profiled sheet is performed according to the formula:

$$\sigma = M/W_{x,min} \leq R_y \gamma_c, \quad (3.1)$$

where  $M=0,16 \text{ kNm}$ ;

$$W_{x,min}=17,9 \text{ cm}^3;$$

$$R_y=220 \text{ MPa};$$

$$\gamma_c=1.$$

$$\sigma = 0,16/17,9 \cdot 10^{-6} = 9 \text{ MPa} < 220 \text{ MPa} - \text{the condition is satisfied.}$$

Calculation by tangential stresses is performed according to the formula:

$$\tau = Q_r/h_r \cdot t_r \leq R_s \cdot \gamma_c, \quad (3.2)$$

where  $Q_r=Q_{max}/3=0,507/3=0,17 \text{ kN}$  - shear force per wall of corrugated sheeting.

$h_r=57 \text{ mm}$  - wall height of corrugated sheet;

$t_r=0,8 \text{ mm}$ . – wall thickness of corrugated sheet;

$$R_s=130 \text{ MPa}$$

$$\gamma_s=1.$$

$$\tau=0,17/57 \cdot 10^{-3} \cdot 0,8 \cdot 10^{-3} = 3,7 \text{ MPa} < 130 \text{ MPa} - \text{the condition is satisfied.}$$

### Проверка по второй группе предельных состояний.

The deflection of the profiled sheet is determined by the formula:

$$f=f_o \leq [f], \quad (3.3)$$

where  $[f] = 1/150$  - ultimate deflection;

$f_o$  - sheet deflection from the normative uniformly distributed load, determined as for the beam with the adopted design scheme.

$$f_o=5 \cdot q_H \cdot l^4 / (384 \cdot E \cdot I_x),$$

where  $q_H=0,396 \text{ kN/m}$ ;

	Name	Signature	Data	<b>EN 406-BA</b>	Sheet
Developer	Fatima-Z. M.				20
Sup-sor	Horb O.				

$l = 1,575$  m - plate length;

$E = 2,06 \cdot 10^5$  MPa;

$I_x = 61,2$  cm<sup>4</sup>.

$f_0 = 5 \cdot 0,396 \cdot 1,575^4 / (384 \cdot 2,06 \cdot 10^8 \cdot 61,2 \cdot 10^{-8}) = 0,0025$  m.

$f = f_0 = 0,0025 < [f] = 0,0067$  – the condition is satisfied.

### Calculation of the rivet's diameter fastening the decking

Fastening corrugated sheeting to the beams is carried out with electric rivets. The diameter of the rivet is determined by the shear strength of welded point joints according to the formula:

$$N = 0,25 \cdot \pi \cdot R_y \cdot \gamma_c \cdot d^2 \cdot n, \quad (3.4)$$

where  $n=1$  - number of rivets in the corrugation;

$N = 0,515 \cdot 1,575 \cdot 0,5/3 = 0,135$  kN - shear force per corrugation.

$d = \sqrt{N / (0,25 \cdot R_y \cdot \gamma_c \cdot n \cdot \pi)} = \sqrt{0,135 / (0,25 \cdot 220 \cdot 10^3 \cdot 1 \cdot 1 \cdot 3,14)} = 2,6 \cdot 10^{-3}$  m = 0,27 cm.

Take a welded point, as according to technological possibilities, the diameter of the welded point must be at least 5 mm.

### Calculation of the deck girder

#### Selecting the steel grade for the beam

Decking beam belongs to the II group of structures. We accept the steel grade BCт3сп.

$R_y = 230$  (MPa);  $R_u = 350$  (MPa);  $R_{un} = 360$  (MPa);

$R_{yn} = 235$  MPa;  $R_s = 0,58 \cdot R_{yn} / \gamma_m$ ;

where  $\gamma_m = 1,025$ ;  $R_s = 0,58 \cdot 235 / 1,025 = 132,976$  MPa.

#### Choice of beam design scheme

We accept a two-span non-split beam design scheme (Fig.4.3).

Collecting loads

Determine the standard load capacity:

$q_0^H = (1,02 \div 1,04) \sum q^H \cdot a = 1,04 \cdot 0,396 \cdot 1,05 = 0,432$  (kN/m).

	Name	Signature	Data	<b>EN 406-BA</b>	Sheet
Developer	Fatima-Z. M.				21
Sup-sor	Horb O.				



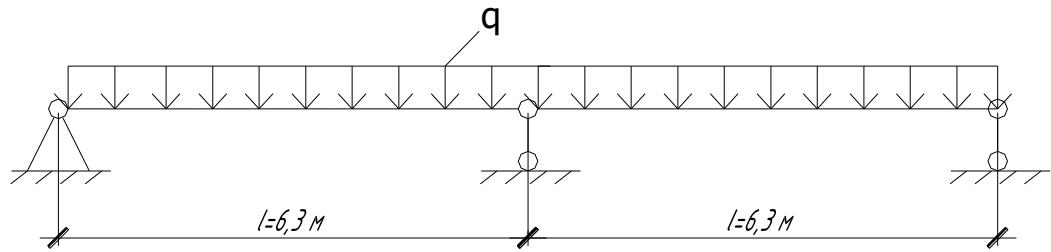

Fig. 3.4. Calculation diagram of the floor beams

Determine the design load:

$$q_{\delta} = (1,02 \div 1,04) \sum q \cdot a = 1,04 \cdot 0,515 \cdot 1,05 = 0,56 \text{ (kN/m)}.$$

### Static calculation

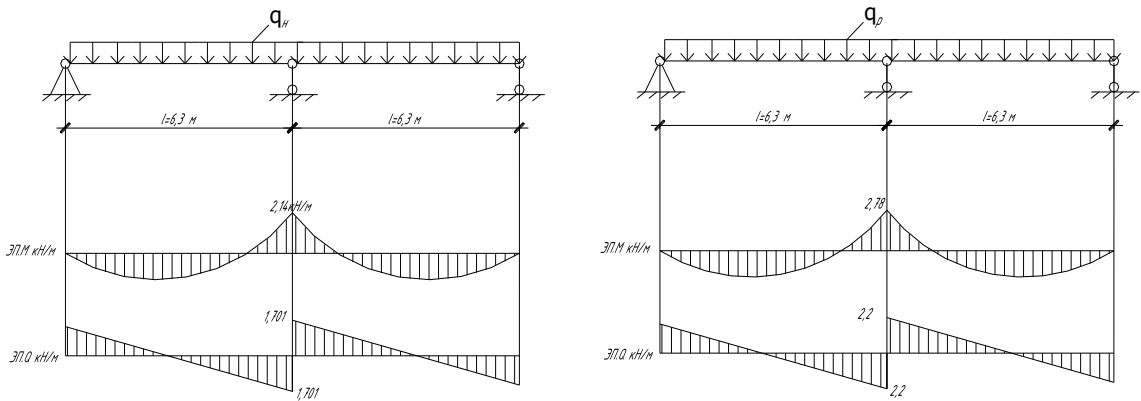

Fig. 3.5. Calculation scheme

$$M_{max} = q_n l^2 / 8 = 0,432 \cdot 6,3^2 / 8 = 2,14 \text{ kNm};$$

$$Q_{max} = 0,625 q_n l = 0,625 \cdot 0,432 \cdot 6,3 = 1,701 \text{ kN}.$$

$$M_{max} = q_p l^2 / 8 = 0,56 \cdot 6,3^2 / 8 = 2,78 \text{ kNm};$$

$$Q_{max} = 0,625 q_p l = 0,625 \cdot 0,56 \cdot 6,3 = 2,2 \text{ kN}.$$

### Determination of the required resistance moment

Beam decking loaded with static load, has a continuous cross-section, therefore, its calculation can be performed taking into account the development of plastic deformations, then the required moment of resistance:

$$W_{mp.} = \frac{M_{max}}{(R_y \gamma_c \cdot c)} = \frac{2,78 \cdot 10^5}{230 \cdot 10^2 \cdot 1,0 \cdot 1,12} = 10,79 \text{ (cm}^3\text{)};$$

where  $\gamma_c = 1,0$ ;  $c = 1,12$ .

	Name	Signature	Data		Sheet
Developer	Fatima-Z. M.			<b>EN 406-BA</b>	22
Sup-sor	Horb O.				

### Selecting the profile type and rolling number

Take the profile according to the assortment [ 10:

$$W_x = 34,8 (\text{cm}^3) > W_{mp} = 10,79 (\text{cm}^3).$$

Geometric characteristics of the section:

$$J_x = 174 (\text{cm}^4); b = 46 (\text{mm});$$

$$t_n = 7,6 (\text{mm}); t_{cm} = 4,5 (\text{mm});$$

$$\rho = 8,59 (\text{kg}); S_x = 20,4 (\text{cm}^3);$$

$$A = 10,9 (\text{cm}^2).$$

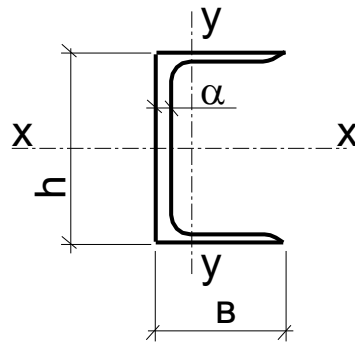

Fig. 3.6. Channel section

### Checking the beam according to the first group of limit states

Normal stress strength:

$$\sigma_x = \frac{M_{max}}{W_x \cdot c} = \frac{2,14 \cdot 10^3}{22,4 \cdot 10^{-6} \cdot 1,12} = 85,3 (\text{MPa});$$

$$\sigma_x = 85,3 < R_y \cdot \gamma_c = 230 (\text{MPa}).$$

Conclusion: the strength of the normal sections is ensured.

Tangential stress strength:

$$\tau = \frac{Q_{max} \cdot S_x}{(t_{cm} \cdot J_x)} = \frac{1701 \cdot 13,3 \cdot 10^{-6}}{0,0045 \cdot 89,4 \cdot 10^{-8}} = 5,6 (\text{MPa});$$

$$\tau = 5,6 < R_s \gamma_c = 132,976 (\text{MPa}).$$

Conclusion: Tangential stress strength is ensured.

Since the beam is continuous, therefore, we check the beam for the simultaneous action of normal and shear stresses on the support:

	Name	Signature	Data	<b>EN 406-BA</b>	Sheet
Developer	Fatima-Z. M.				23
Sup-sor	Horb O.				

$$\sigma_{np} = \sqrt{\sigma_1^2 + 3\tau_1^2} \leq R_y \gamma_c, \text{ where } \sigma_1 = \frac{M_1}{W_x} = \frac{2,14 \cdot 10^3}{22,4 \cdot 10^{-6}} = 85,3 \text{ (MPa);}$$

$$\tau_1 = \frac{Q_1 \cdot S_x}{t_{cm} \cdot J_x} = \frac{1701 \cdot 13,3 \cdot 10^{-6}}{0,0045 \cdot 89,4 \cdot 10^{-8}} = 5,6 \text{ (MPa);}$$

$$\sigma_{np} = \sqrt{85,3^2 + 3 \cdot 5,6^2} = 85,84 < R_y \cdot \gamma_c = 230 \text{ (MPa).}$$

$$\sigma_{np} = \sqrt{85,3^2 + 3 \cdot 5,6^2} = 85,84 < R_y \cdot \gamma_c = 230 \text{ (MPa).}$$

Conclusion: The strength from the combined action of normal and shear stresses on the support is ensured.

### Testing of beams according to the second group of limit states

The deflection is determined by the formula:

$$f = f_o \leq [f], \quad (3.5)$$

where  $[f] = l/250$  - ultimate deflection;

$f_o$  - deflection of the beam from the normative uniformly distributed load, determined as for the beam with the adopted design scheme.

$$f_o = 5 \cdot q_H \cdot l^4 / (384 \cdot E \cdot I_x),$$

where  $q_H = 0,432 \text{ kN/m}$ ;

$l = 6,3 \text{ m}$  - beam length;

$E = 2,06 \cdot 10^5 \text{ MPa}$ ;

$I_x = 174 \text{ cm}^4$ .

$$f_o = 5 \cdot 0,432 \cdot 6,3^4 / (384 \cdot 2,06 \cdot 10^8 \cdot 174 \cdot 10^{-8}) = 0,024 \text{ m.}$$

$$f = f_o = 0,024 < [f] = 0,0252 - \text{the condition is satisfied.}$$

Conclusion: the stiffness of the beam is ensured.

Проверка балки на общую устойчивость

Since the load is transmitted through a continuous rigid metal deck, continuously supported by the compressed chord of the beam and reliably connected to it by means of a welded seam, the overall stability test may not be performed.

We do not calculate the local stability of the flanges and walls of the rolled beams, since it is provided by the section.

	Name	Signature	Data	<b>EN 406-BA</b>	Sheet
Developer	Fatima-Z. M.				24
Sup-sor	Horb O.				

## 3.2. Calculation of the superstructure floor column

### Choice of design scheme

Determination of design column length.

The calculated length is determined by the formula:  $l=l_0 \cdot \mu$ ,

where  $\mu$  - coefficient of design length, depending on the conditions of the column fastening;

$l_0$  - design column length.

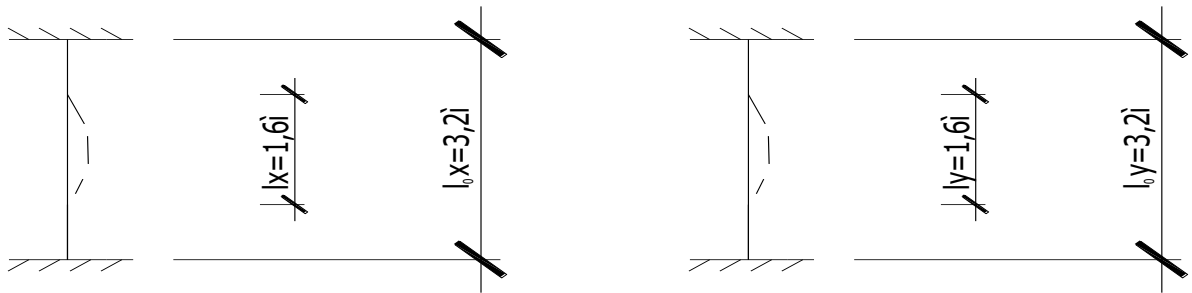

Fig.3.7. Calculation diagrams in the planes X-X and Y-Y.

$$l_x = 3,2 \cdot 0,5 = 1,6 \text{ m}$$

$$l_y = 3,2 \cdot 0,5 = 1,6 \text{ m},$$

where  $\mu_x = 0,5$ ;

$$\mu_y = 0,5.$$

### Selection of column cross section

The load per column is taken from the table of force combinations:  
 $M=181,657 \text{ kNm}$ ;  $N=-58,87 \text{ kN}$ .

Preliminarily set the height of the column cross section  $h=200 \text{ mm} > (1/30) H$ .

Determine:  $\lambda_x = l_x / 0,42h \sqrt{R_y/E}$ ,

where  $R_y = 240 \text{ MPa}$ ;

$$E = 2,06 \cdot 10^5 \text{ MPa}.$$

$$\lambda_x = 160 / 0,42 \cdot 20 \cdot \sqrt{24 / 2,06 \cdot 10^4} = 0,65$$

$$m_{ef} = M / (N \cdot 0,35h) = 58,87 \cdot 10^2 / (181,657 \cdot 0,35 \cdot 20) = 4,6$$

Coefficient  $\varphi_e$  determine depending on  $\lambda_x$  and  $m_{ef}$ :  $\varphi_e = 0,297$ .

	Name	Signature	Data	<b>EN 406-BA</b>	Sheet
Developer	Fatima-Z. M.				25
Sup-sor	Horb O.				

Required cross-sectional area:  $A_{mp} = N / (\varphi_e \cdot R_y \cdot \gamma_c)$ ,

where  $\gamma_c = 1$ .

$$A_{tp} = 181,657 / (0,297 \cdot 24 \cdot 1) = 25,5 \text{ cm}^2.$$

According to the assortment we accept I 20K1 with geometric characteristics:  $A = 51,7 \text{ cm}^2$ ,  $W_x = 383 \text{ cm}^3$ ,  $i_x = 8,49 \text{ cm}$ ,  $i_y = 5,03 \text{ cm}$ ,  $h = 194,4 \text{ mm}$ ,  $b = 200 \text{ mm}$ ,  $t = 9,8 \text{ mm}$ ,  $s = 6,3 \text{ mm}$ ,  $I_x = 3730 \text{ cm}^4$ ,  $I_y = 1310 \text{ cm}^4$ .

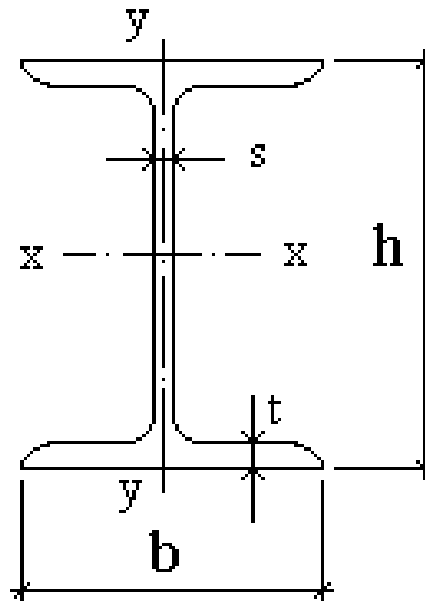

Fig.3.8 Sectional view of the column of the superstructure floor

### Column stability check

Check the stability of the designated section:

$$\lambda_x = l_x / i_x \cdot \sqrt{R_y / E} = 160 / 8,49 \cdot \sqrt{24 / 2,06 \cdot 10^4} = 0,64$$

$$m = (M/N) \cdot (A/W_x) = (58,87 \cdot 10^2 / 181,657) \cdot (51,7 / 383) = 4,4$$

When  $A_f/A_w = 200 \cdot 9,8 / (194 - 2 \cdot 9,8) \cdot 6,3 = 1,78$  the coefficient of the section shape influence calculated by the formula:

$$\eta = (1,9 - 0,1m) - 0,02(6-m) \cdot \lambda_x = (1,9 - 0,1 \cdot 4,4) - 0,02(6 - 4,4) \cdot 0,64 = 1,69$$

$$m_{ef} = \eta \cdot m = 1,69 \cdot 4,4 = 7,4$$

Find  $\varphi_e = 0,195$

Stability in the frame plane:

	Name	Signature	Data	<b>EN 406-BA</b>	Sheet
Developer	Fatima-Z. M.				26
Sup-sor	Horb O.				

$$N/(\varphi_e \cdot A) = 181,657 / (0,195 \cdot 51,7 \cdot 10^{-4}) = 180,1 \text{ MPa} <$$

$R_y \cdot \gamma_c = 240 \cdot 1 = 240 \text{ MPa}$  - stability is ensured.

### Check of column stability from the plane of moment action

$$N/c \cdot \varphi_y \cdot A \leq R_y \cdot \gamma_c,$$

$$\text{where } c = \beta / (1 + \alpha \cdot m_x),$$

$$\text{where } m_x = m = 4,4;$$

$$\alpha = 0,65 + 0,05 \cdot m_x;$$

$$\alpha = 0,65 + 0,05 \cdot 4,4 = 0,87$$

$$\beta = 1, \text{ т.к. } \lambda_y < \lambda_c$$

$$\text{where } \varphi_c = 0,598 \text{ when } \lambda_c = 3,14 \cdot \sqrt{E/R_y} = 92;$$

$$\varphi_y = 0,925 \text{ when } \lambda_y = l_y/i_y = 160/5,03 = 31,8 \text{ и } m_{ef} = 1,1$$

$$c = 1 / (1 + 0,87 \cdot 4,4) = 0,207$$

$$181,657 / (0,207 \cdot 0,925 \cdot 51,7 \cdot 10^{-4}) = 183,5 \text{ MPa} < R_y \cdot \gamma_c = 240 \cdot 1 = 240 \text{ MPa} -$$

the condition is satisfied.

Finally, as a column we take I 20K1.

### Calculation of the transom of the superstructure floor

#### Selection of the calculation scheme

Calculation scheme of the girder is a single span beam with rigid fixation at the edges:

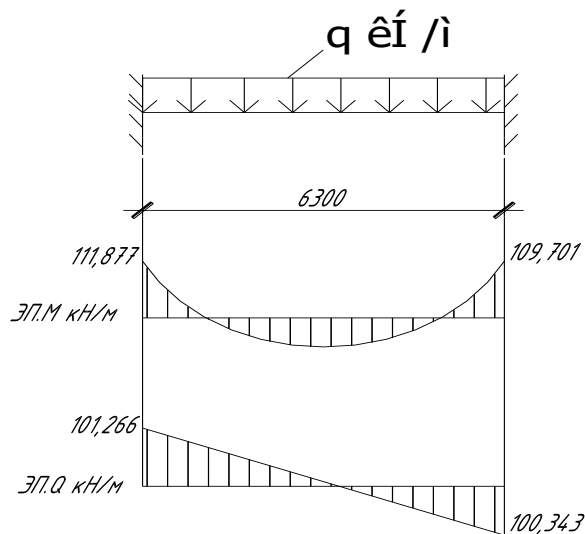

Fig. 3.9. Calculation scheme of the beam

	Name	Signature	Data	<b>EN 406-BA</b>	Sheet
Developer	Fatima-Z. M.				27
Sup-sor	Horb O.				

## Selecting the cross-section of the beam

Calculation forces in the beam: bending moment  $M_{\max}$  and shear force  $Q_{\max}$  in the characteristic sections are determined at their disadvantageous combination:

$$M_{\max} = -111,877 \text{ kNm};$$

$$Q_{\max} = -101,266 \text{ kN}.$$

The required moment of resistance of the beam section loaded with static load and having a continuous cross-section can be determined taking into account the development of plastic deformations:

$$W_{\text{TP}} = M_{\max} / R_y \gamma_c c, \quad (3.6)$$

where  $R_y = 240 \text{ MPa}$ ;

$$\gamma_c = 1;$$

$$c = 1,12.$$

$$W_{\text{TP}} = 111,877 \cdot 10^5 / 240 \cdot 10^2 \cdot 1,12 = 416,2 \text{ cm}^3.$$

According to the given value  $W_{\text{TP}}$  by assortment we accept an I-beam I 30 with design characteristics:  $W_x = 472 \text{ cm}^3$ ;  $I_x = 7080 \text{ cm}^4$ ;  $S_x = 268 \text{ cm}^3$ ;  $A = 46,5 \text{ cm}^2$ ;  $h = 300 \text{ mm}$ ;  $b = 135 \text{ mm}$ ;  $s = 6,5 \text{ mm}$ ;  $t = 10,2 \text{ mm}$ ; linear density  $36,5 \text{ kg/m}$ .

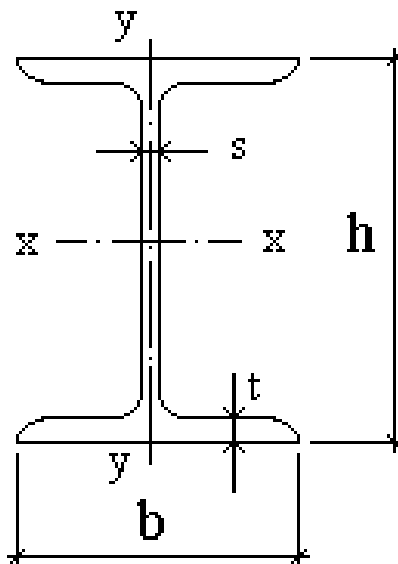

Fig. 3.10. Cross-section of the superstructure floor beam

	Name	Signature	Data	<b>EN 406-BA</b>	Sheet
Developer	Fatima-Z. M.				28
Sup-sor	Horb O.				

## Checking the beam according to the first group of limit states

### *Calculation of strength:*

$$\sigma_x = M_{\max} / W_x \cdot c = 111,877 \cdot 10^3 / 472 \cdot 10^{-6} \cdot 1,09 = 217,5 \text{ MPa} <$$

$R_y \cdot \gamma_c = 240 \cdot 1,1 = 264 \text{ MPa}$  – the strength of the normal sections is ensured.

$$c = 1,09.$$

$$\text{Underexposed: } (R_y \cdot \gamma_c - \sigma_x) / R_y \cdot \gamma_c \cdot 100\% = (264 - 217,5) / 264 = 17\%$$

*Calculation of the tangential stresses strength* is performed by the formula:

$$\tau = Q_{\max} \cdot S / (t_{cr} \cdot I_x) = 101,266 \cdot 268 \cdot 10^{-6} / (6,5 \cdot 10^{-3} \cdot 7080 \cdot 10^{-8}) = 58,9 \text{ MPa} <$$

$R_s \cdot \gamma_c = 138 \cdot 1,1 = 151,8 \text{ MPa}$  - tangential stress strength is ensured.

***Check the strength of the beam from the combined action of normal and shear stresses:***

$$\sigma_{np} = \sqrt{\sigma_1^2 + 3\tau_1^2} \leq R_y \gamma_c, \text{ where}$$

$$\sigma_1 = \frac{M_1}{W_x} = \frac{111,877 \cdot 10^3}{472 \cdot 10^{-6}} = 237 \text{ (MPa)};$$

$$\tau_1 = \frac{Q_1 \cdot S_x}{t_{cm} \cdot J_x} = \frac{101,266 \cdot 268 \cdot 10^{-6}}{0,0065 \cdot 7080 \cdot 10^{-8}} = 58,9 \text{ (MPa)};$$

$$\sigma_{np} = \sqrt{237^2 + 3 \cdot 58,9^2} = 258 < R_y \cdot \gamma_c = 264 \text{ (MPa)}.$$

Conclusion: The strength from the combined action of normal and shear stresses on the support is ensured.

### ***Check for general stability***

Проверяем общую устойчивость балки по формуле:

$$\sigma = \frac{M_{\max}}{\varphi_b \cdot W_c} \leq R_y \cdot \gamma_c; \quad (3.7)$$

$$\alpha = 1,54 \cdot \frac{I_t}{I_y} \left( \frac{l_{ef}}{h} \right)^2,$$

where  $l_{ef}$  - design beam length;

	Name	Signature	Data	<b>EN 406-BA</b>	Sheet
Developer	Fatima-Z. M.				29
Sup-sor	Horb O.				



h – full section height;

$I_t$  - moment of inertia of the section in torsion;

$$\alpha = 1,54 \cdot \frac{17,4}{337} \left( \frac{1,575}{0,3} \right)^2 = 2,19;$$

$$\psi = 2,25 + 0,07 \cdot \alpha = 2,25 + 0,07 \cdot 0,104 = 2,26;$$

$$\varphi_1 = \psi \cdot \frac{I_y}{I_x} \left( \frac{h}{l_{ef}} \right)^2 \cdot \frac{E}{R_y} = 2,26 \cdot \frac{337}{7080} \cdot \left( \frac{0,3}{1,575} \right)^2 \cdot \frac{2,06 \cdot 10^5}{240} = 3,34;$$

As the coefficient  $\varphi_b$  must be equal to the coefficient of and at the same time must not exceed 1, then we accept  $\varphi = 1$

$$\sigma = \frac{111,877 \cdot 10^3}{1 \cdot 472 \cdot 10^{-6}} = 237 \leq R_y \cdot \gamma_c = 264 \text{ MPa.}$$

Conclusion: general stability of the beam is ensured.

### ***Checking for local stability***

Local stability of flanges and walls of rolled beams is provided by the assortment.

## **Testing of beams according to the second group of limit states**

The stiffness of the beams is ensured if the condition:

$$(f/b) \leq [f/b],$$

where  $[f/b]$  – the ultimate deflection of the beam, which is equal to  $1/250 b = 6,3 \text{ m}$  – beam span.

f - deflection of the beam from the action of the standard load.

The deflection is determined from the standard load by the rules of structural mechanics by the Vereshchagin method, for this purpose, in the section where the deflection is determined, a unit force  $P=1$  is applied and the moment diagram is drawn (Fig. 3.11.). Multiply the load and the epure from the unit load and obtain the deflection.

	Name	Signature	Data	<b>EN 406-BA</b>	Sheet	
Developer	Fatima-Z. M.				<b>EN 406-BA</b>	30
Sup-sor	Horb O.					30

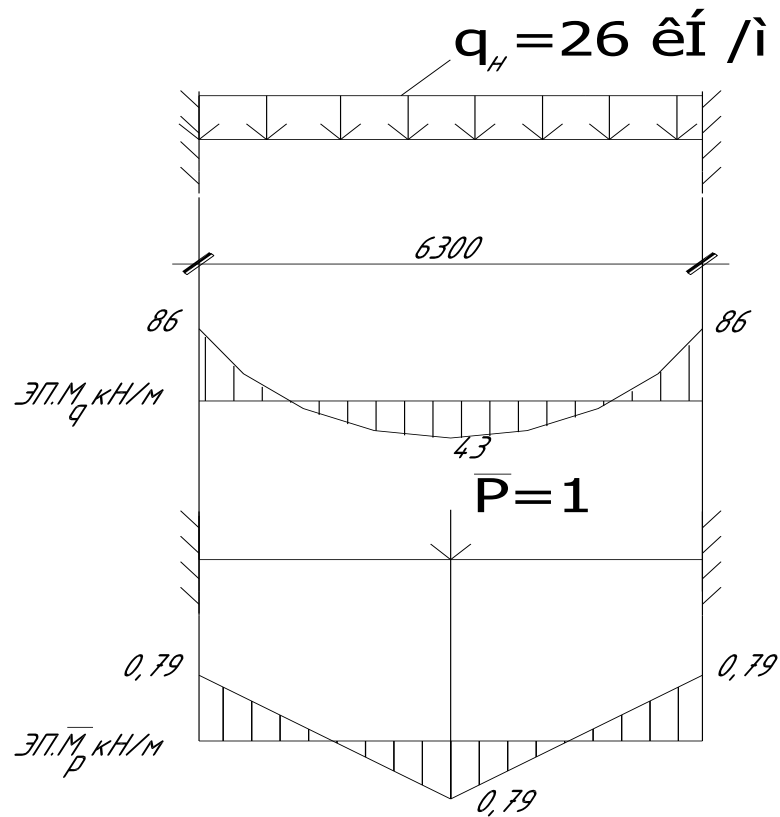

Fig. 3.11. Diagrams  $M_q$  и  $M_p$

$$f = 1/EI [1/6(2ab+2bd-ad-bc) + ql^3/12(-c+d/2) + 1/6(2ac+2bd-ad-bc) + ql^3/12(c-d/2)] = 1/2,06 \cdot 10^8 \cdot 7080 \cdot 10^{-8} (3,15/6(2 \cdot 86 \cdot 0,79 + 2 \cdot 43 \cdot 0,79 - 86 \cdot 0,79 - 43 \cdot 0,79) + 26 \cdot 3,15^3/12) \cdot 2 = 0,017 \text{ m};$$

The actual deflection is divided by the span, resulting in the relative deflection.

$(f/b) = 0,017/6,3 = 0,0027 < [f/b] = 6,3/250 = 0,0252$  – beam stiffness is ensured.

Finally accept as a beam of the superstructure floor I 30.

	Name	Signature	Data	<b>EN 406-BA</b>	Sheet
Developer	Fatima-Z. M.				31
Sup-sor	Horb O.				

## 4. Basics and foundations

### 4.1. Evaluation of engineering and geological conditions

Designing foundations and foundations begins with the study and general evaluation of the entire strata and its individual layers. The assessment is made on the basis of geological maps, cross-sections, columns, which are given in the reports on engineering and geological surveys.

According to the engineering and geological section, the hotel building is located on a site which has a quiet relief.

The soils have a layered overlaying with the sustained occurrence of layers. The top layer is represented by bulk soils consisting of pebbles, sand and covers the site with a layer up to 1m thick.

Below 1 to 2.8 m, sandy clay of solid consistence lies, from 2.8 to 3.4 m, dusty sand, from 3.4 to 4.6 m, sandy clay of solid consistence.

From the depth of 4.6 m, pebble-like soil with sandy aggregate is underlain.

Pebble soil is a bearing layer.

Underground waters are met at the depth of 5.5 m.

Normative depth of seasonal freezing for Zaporizhzhya is 0.9 m.

Category of soils on seismic effects - II.

### 4.2. Calculation of foundations

#### Testing the strength of foundations with increasing loads

In order to check whether the foundation will withstand the additional load from the addition of another floor, it will be sufficient to perform the calculation of the most heavily loaded foundation.

We collect the loads on the existing foundation in a tabular form.

	Name	Signature	Data		Sheet
Developer	Fatima-Z. M.			<b>EN 406-BA</b>	
Sup-sor	Horb O.				32

Table 4.1. Load on the foundation

Type of load	Normative loads		Load factor, $\gamma_f$	Design loads, kN
	per unit area, kN/m <sup>2</sup>	from the cargo area, kN		
<b>Constant loads</b>				
asbestos cement	0.119	4,723	1.2	5,66
crate	0.034	1,34	1.1	1,48
rafters	0.889	35,28	1.1	38,81
runs	0.113	4,48	1.1	4,93
stands	0.156	6,191	1.1	6,81
floor slabs on 4 floors	12	476,28	1.1	523,9
from the concrete floor on the slab	3,75	148,8	1,3	193,48
brick column 640x640 mm	88,47	88,47	1.1	97,3
<b>Total</b>	–	<b>765,7</b>	–	<b>872,37</b>
<b>Temporary loads</b>				
Per 1 m <sup>2</sup> of roof projection from snow	1.070	42,46	1.6	67,95
including long-acting (with a reduction factor of 0.3)	0.321	12,74	1.6	20,38
Short-term per 1 m <sup>2</sup> of attic floor	0.7	27,78	1.3	36,12
<b>Total</b>	–	<b>82,98</b>	–	<b>124,45</b>
<b>Full load</b>		<b>848,68</b>		<b>996,82</b>

For this facility the foundation is reinforced concrete piles of grade C 6-30, long L = 6 m with a cross section of 0.4x0.4 m. united by a reinforced concrete rover. The piles are immersed in the ground by hammering with a tubular diesel hammer C-996.

	Name	Signature	Data	<b>EN 406-BA</b>	Sheet
Developer	Fatima-Z. M.				33
Sup-sor	Horb O.				

Pile cross-section area  $A=0.3 \times 0.3=0.09$  m, pile perimeter  $u=0.3 \times 4=1.2$  m

At pile immersion depth of 6.78 m for the gravel-pebble soil, interpolating, we find the soil resistance under the bottom end of the pile  $R=9.601$  MPa.

For piles loaded with diesel hammers, the values of soil conditions coefficients under the bottom end of the pile  $\gamma_{CR}=1$  and on the side surface  $\gamma_{cf}=1$ .

The thickness of the soil penetrated by the pile is divided into layers and for the first layer of soil at an average depth of layer location  $h_1=1.68$  m for the bulk gravel-pebble soil  $f_1=0.03976$ .

For the second soil layer at an average depth of layer location  $h_2=3.18$  m for sandy loam of solid consistence,  $f_2=0.0489$  MPa.

For the third layer of the ground at an average depth of layer location  $h_3=4.48$  m for silty sand  $f_3=0.02796$  MPa.

For the fourth layer of the ground at an average depth of layer location  $h_4=5.38$  m for sandy loam of firm consistence,  $f_4=0.0489$  MPa.

For the fifth soil layer at an average depth of layer location  $h_5=6.48$  m for gravel-pebble soil,  $f_5=0.05896$  MPa.

Bearing capacity of a single pile is determined by the formula:

$$\Phi = \gamma_c (\gamma_{CR} \cdot R \cdot A + u \cdot \sum \gamma_{cfi} \cdot f_i \cdot l_i) = 1 \cdot (1 \cdot 9,601 \cdot 0,09 + 1,2 \cdot 1 \cdot (0,03976 \cdot 1 + 0,0489 \cdot 2 + 0,02796 \cdot 1 + 0,05676 \cdot 1,2 + 0,05896 \cdot 1)) = 1201,8 \text{ kN.}$$

where  $\gamma_c=1$  – pile-in-soil condition factor;

$\gamma_{CR}=1$  – coefficient of soil conditions under the bottom end of the pile;

$\gamma_{cf}=1$  – coefficient of soil conditions on the lateral surface;

$R=9,601$  MPa – soil resistance under the bottom end of the pile;

$A=0,16$  m<sup>2</sup> – the area of pile support on the ground, taken according to the cross-sectional area of the pile;

$u=1,2$  m – external perimeter of the pile cross section;

	Name	Signature	Data	<b>EN 406-BA</b>	Sheet
Developer	Fatima-Z. M.				<b>34</b>
Sup-sor	Horb O.				

$f_i$  - design resistance of the  $i$ -th layer of the base soil on the side surface of the pile;

$l_i$  – thickness of the  $i$ -th ground layer of the layer to be cut through;

The design load allowed on the pile on the ground is:

$$F = \frac{\Phi}{\gamma_g} = \frac{1201,8}{1,4} = 858,4 \text{ kN}$$

where  $\Phi$  – design load capacity of a single pile;

$\gamma_g=1,4$  – reliability factor.

As the number of piles in the foundation is 2, the design load allowed on the pile on the ground is:

$$F=858,4 \cdot 2=1716,8 \text{ kN}$$

$$F=1716,8 \text{ kN} > N=848,68 \text{ kN}$$

The load-bearing capacity of the pile on the ground is ensured.

Find the weight of the beam per 1 m of the foundation:

$$G_p=2500 \cdot 0,4 \cdot 0,4 \cdot 1=400 \text{ kN}=4 \text{ kN}$$

Load per cluster of two piles:

$$N=848,68+4=852,68 \text{ kN}$$

For the ground of the first layer - gravel and pebble soil with porosity coefficient  $e=0,55$ , the angle of internal friction  $\varphi_{n1}=40^\circ$ .

For the soil of the second and fourth layer - sandy loam of solid consistency with a porosity coefficient  $e=0,65$  the angle of internal friction  $\varphi_{n2}=32^\circ$ .

For the soil of the third layer - pulverized sand with a porosity coefficient  $e=0,65$ , the angle of internal friction  $\varphi_{n3}=32^\circ$ .

For the fifth layer - gravel and pebble soil with a porosity coefficient  $e=0,55$ , the angle of internal friction  $\varphi_{n5}=40^\circ$ .

The averaged angle of internal friction of soils penetrated by the pile, we find by the formula:

	Name	Signature	Data	<b>EN 406-BA</b>	Sheet
Developer	Fatima-Z. M.				<b>35</b>
Sup-sor	Horb O.				

$$\alpha = \frac{\gamma_{ncc}}{4} = \frac{1}{4} \left( \frac{40 \cdot 1 + 32 \cdot 2 + 32 \cdot 0,6 + 32 \cdot 1,2 + 40 \cdot 1}{1 + 2 + 0,6 + 1,2 + 1} \right) = 8^{\circ}68',$$

Find the width of the conditional foundation:

$$B_{ycn} = 0,9 + 2 \cdot (1 + 2 + 0,6 + 1,2 + 1) \cdot \operatorname{tg} 8^{\circ}68' = 2,67 \text{ m}$$

Weight of soil in the volume of ABCD:

$$G_{rp} = 1800 \cdot 1 \cdot 2,67 \cdot 1 + 1660 \cdot 2 \cdot 2,67 \cdot 1 + 1650 \cdot 0,6 \cdot 2,67 \cdot 1 + 1660 \cdot 1,2 \cdot 2,67 \cdot 1 + 2100 \cdot 1 \cdot 2,67 \cdot 1 = 27239,34 \text{ kg} = 272,39 \text{ kN}$$

The pressure under the foot of the conditional foundation according to the formula:

$$P_{cp} = \frac{n(N + G_c + G_{cp} + G_p)}{A_{ycn}} = \frac{852,68 + 25 + 272,39 + 4}{2,67 \cdot 1} = 432,2 \text{ kN/m}^2$$

We calculate the design resistance of the foundation soil under the base of the conditional foundation using the formula:

$$R = R_0 \left[ 1 + k_1 (b - b_0) / b_0 \right] + k_2 \mu'_2 (d - d_0), \quad (4.1)$$

where b and d – respectively the depth of the conditional foundation;

$\mu'_2$  – calculated value of specific weight of the soil located above the base of the conditional foundation;

$\mu'_2 = 21 \text{ kN/m}^3$  - for pebble soil;

$\mu'_2 = 16,6 \text{ kN/m}^3$  - or hard sandy loam;

$\mu'_2 = 16,5 \text{ kN/m}^3$  - for dusty sand;

$\mu'_2 = 18 \text{ kN/m}^3$  - for bulk soil;

$$\mu'_2 = 1 \cdot 18 + 16,6 \cdot 2 + 16,5 \cdot 0,6 + 16,6 \cdot 1,2 + 21 \cdot 1 / 1 + 2 + 0,6 + 1,2 + 1 = 17,58 \text{ kN/m}^3,$$

$$k_1 = 0,125$$

$$k_2 = 0,25$$

$$b_0 = 1 \text{ m}$$

$$d_0 = 2 \text{ m}$$

$$R = 500 \left[ 1 + \frac{0,125 \cdot (2,67 - 1)}{1} \right] + 0,25 \cdot 17,58 (6,78 - 2) = 625,38 \text{ kN/m}^2$$

	Name	Signature	Data		Sheet
Developer	Fatima-Z. M.			<b>EN 406-BA</b>	36
Sup-sor	Horb O.				

The basic requirement for the calculation of the pile foundation for the second group of limiting states is satisfied:

$$P_{cp} = 432,2 \text{ kN/m}^2 < R = 660,03 \text{ kN/m}^2$$

It is not necessary to calculate settlements, since the stresses at the base of the foundation do not exceed the calculated resistance of the foundation soil.

### Determination of design forces in the monolithic grillage

Collection of loads on the monolithic derrick along the axis "1".

Calculated loads per linear meter of the monolithic derrick:

permanent:  $q_n = 138,47 \text{ kN/m}$ ;

temporary:  $q_{bp} = 6,89 \text{ kN/m}$ ;

its own weight  $q_{cb} = 0,4 \cdot 0,4 \cdot 2500 \cdot 2,2 / 100 = 8,8 \text{ kN/m}$ ;

total  $q = 138,47 + 6,89 + 8,8 = 154,16 \text{ kN/m}$ ;

Calculation scheme of the beam - multi-span continuous beam loaded with a uniformly distributed load.

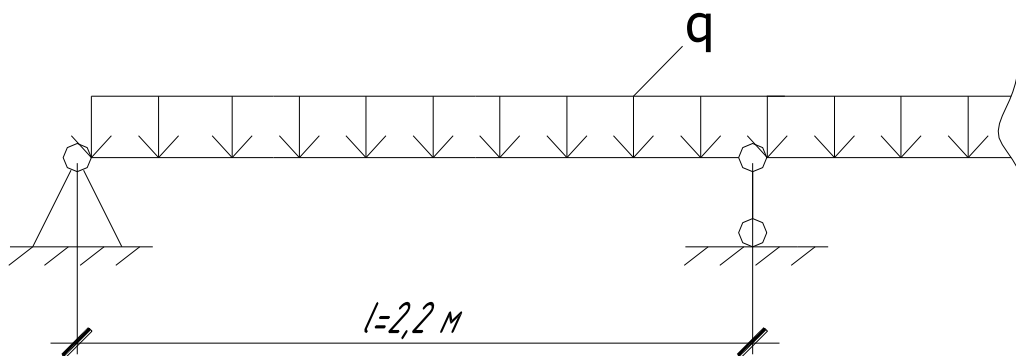

Fig.4.1. Calculation diagram of the vertical beam on axis "1"

Determine the design forces in the monolithic grillage along axis "3":

$$M = \frac{q \cdot l^2}{8} = \frac{154,16 \cdot 2,2^2}{8} = 93,27 \text{ kN/m};$$

$$Q = \frac{q \cdot l}{2} = \frac{154,16 \cdot 2,2}{2} = 169,57 \text{ kN}.$$

	Name	Signature	Data	<b>EN 406-BA</b>	Sheet
Developer	Fatima-Z. M.				37
Sup-sor	Horb O.				



## Concrete and reinforcement strength characteristics

Concrete class C 12/15:

$R_b = 9.5$  – design resistance of concrete in compression;

$R_{bt} = 1.0$  – design tensile strength of concrete;

$\gamma_{b2} = 0.9$  – concrete condition factor;

$E_b = 21000$  MPa – concrete modulus of elasticity;

Armature longitudinal working class A400

$R_s = 365$  MPa – design tensile strength;

$E_s = 200000$ MPa – modulus of reinforcement elasticity.

### Fittings selection

Working height of the beam cross section:

$$h_0 = h - a = 40 - 3 = 37 \text{ cm}$$

For the foundation beam along the axis «3»

Calculate:

$$\alpha_M = M / R_b \cdot b \cdot h_0^2 = 93,27 \cdot 10^3 / 9,5 \cdot 0,9 \cdot 0,4 \cdot 0,4^2 = 0,17$$

$$\zeta = 0,905$$

$$A_s = M / \zeta \cdot h_0 \cdot R_s = 93,27 \cdot 10^3 / 0,905 \cdot 0,37 \cdot 365 \cdot 10^6 = 7,06 \text{ cm}^2$$

$$A_s = 7,06 \text{ cm}^2 < A_{stp.} = 8,04 \text{ cm}^2$$

## 5. Construction technology

### 5.1. Works of the preparatory period of the superstructure

Before you begin the main work on the construction of the superstructure, you should prepare the site. The preparation consists in the dismantling of the existing roof structures. Dismantling is carried out by segments in succession from top to bottom.

Before starting the dismantling work, thoroughly examine the existing parts of the building and their structures in order to establish their technical

	Name	Signature	Data	<b>EN 406-BA</b>	Sheet
Developer	Fatima-Z. M.				38
Sup-sor	Horb O.				

condition and safe working conditions. After that, check the availability of electricity, radio, telephone lines on the roof with their subsequent dismantling.

The first step in the production of preparatory work is the device of fencing around the perimeter of the building in the form of a canopy. It will be designed to protect passersby from the fall of small construction materials and prevent falling workers.

Dismantling the roof begin with the dismantling of all devices and structures that rise above the roof, namely, antennas, masts, exhaust pipes, attic. Dismantling roll-covering over the attic is carried out by cutting the roof covering, tear it away from the base, with its subsequent roll-up and removal from the roof. Then carry out the dismantling of slabs of coverage with their subsequent warehousing in the area. Dismantling of the attic walls, made of sand-lime brick, begin from the top down with the arranged scaffolding. On the scaffolding, pallets are placed on which bricks cleaned of mortar are placed. Using a crane, pallets of bricks are removed and stored on the site.

After completing the work on the dismantling of the attic we make the removal of the main roll roofing. Disassembly of roofing begins with cutting it into strips 50-100 cm wide. To do this, firstly, with a sharpened crowbar the carpet is torn from its base, and then, using reinforced scissors, cut the carpet. Rolled coating, torn from the base, is rolled up and removed from the building under repair. Next, remove the existing insulation. If it is in the form of slabs, it is stored under the shelter, protecting it from direct atmospheric precipitation. Bulk materials are removed with the help of hoppers in containers on the site, and in their absence under the shelter.

After that, dismantle the parapet fence, made of sand-lime brick. Dismantling is carried out with bricks cleaned of mortar and its subsequent laying on pallets, which are removed from the roof with a crane and placed on the site.

It is necessary to make a supply of electricity from the control room by cable. At the output of the cable connected to the distribution box with the

	Name	Signature	Data	<b>EN 406-BA</b>	Sheet
Developer	Fatima-Z. M.				39
Sup-sor	Horb O.				

switch and "automatic". Distribution box should be protected from the effects of precipitation.

Another process of the preparatory period is the manufacture of building structures. Manufacture of metal structures is made on the territory of the forge shop. Assemble the structures on the aligned racks, in compliance with the requirement of SP 53-101-98.

We organize the way of movement of the crane and vehicles that bring the assembled structures.

### **Technological map for the installation of the building frame**

Before installation work is performed, the steel structures shall be subject to acceptance by the technical control department. Deviations in the overall dimensions, in the position of mounting assemblies and mounting holes, in the position of mounting and working tables and other parts of the structural elements must not exceed the permitted values.

For columns: size  $l$  from the bottom surface of the shoe plate to the group of mounting holes of the transoms and other elements adjacent to the column at  $l \leq 10$  m - deviation not more than 10 mm; size from the supporting surface of the working table of the support to the first mounting, adjacent to the column element - 1 mm; height of the column section at the joint - 2 mm; deflection arrow of the column element -  $1/1000$  of the element length, but not more than 15 mm; size between any groups of interrelated mounting holes of the elements adjoining the column - 2 mm.

For beams: the span  $l$  of beams between the outermost mounting holes or outer surfaces of end plates at  $l \leq 25$  m - 10 mm; the deflection of the beam sending element -  $1/1000$  of the length, but not more than 15 mm ; the height of the beam from the bottom of the supporting surface to the top of the upper chord - 3 mm.

For ties: the distance between outermost mounting holes, which determine the span of the element - 3 mm; the deflection range of the departing

	Name	Signature	Date	<b>EN 406-BA</b>	Sheet	
Developer	Fatima-Z. M.					40
Sup-sor	Horb O.					

element - 1/1000 of the length, but not more than 15 mm; the distance between groups of mounting holes on the element - 3 mm.

The manufactured building structures shall be primed and marked in accordance with the working drawings and installation drawings. Details for slinging and assembling of steel structures, as well as for securing the scaffolding and fixing welded, assembly joints shall be installed during the fabrication of these structures. The milled ends which transmit the forces and the inner walls of the holes for hinged bolts shall be lubricated with technical Vaseline, Tavot or Solidol, and the holes shall be protected with wooden plugs.

Installation of steel structures shall be performed with comprehensive mechanization of the processes of transportation, warehousing, prefabrication and installation of structures.

Installation of steel structures shall be performed only after the following preparatory works:

- a) arrangement of access roads and paths, as well as the erection of permanent buildings and structures that can be used for construction needs;
- b) preparation of storage sites and prefabricated assembly areas;
- c) supply of electricity, water and air to the places of consumption;
- d) installation, commissioning and acceptance of installation mechanisms and arrangement of crane ways.

Platforms, ladders, cradles and other devices used in mounting, shall be, as a rule, inventory.

Installation of steel skeletons of the multi-span and multi-storey buildings, as well as buildings of significant length must be performed in spatially rigid blocks with a complete assembly of all structural elements of each block. Installation work is allowed after the handover-acceptance of all the foundations of the building or the relevant block.

The axes of the steel structures shall be fixed on the metal parts concreted in the body of the foundations outside the contour of the structure support. Deviations from the design dimensions along the axes and foundation

	Name	Signature	Date	<b>EN 406-BA</b>	Sheet	
Developer	Fatima-Z. M.					41
Sup-sor	Horb O.					

elevations shall be entered in a special statement attached to the certificate of acceptance of the foundations.

Deviations in the position of supports for steel structures, as well as in the dimensions and location of supporting embedded parts shall not exceed the following values:

- deviations of the support surface (when resting directly on the surface of the foundations erected to the design elevation of the columns' footings, without the subsequent filling with cement mortar) in height - 2 mm;

- deviations in the height of the upper plane of the base plate and the supporting parts - 1.5 mm;

- deviation of anchor bolts, located outside the contour of the structure support - 10 mm;

- deviation of the length of the anchor bolt part that protrudes over the support surface - 20 mm.

Anchor bolts for steel structures must be installed in their designed position and concreted at the same time as the foundation. The anchor bolt threads shall be protected against damage (with caps, felt).

The procedure of delivery of the steel structures to the construction site shall be consistent with the accepted sequence of installation works.

Unloading and storage of steel structures before installation, as well as their transportation within the construction site shall be performed under the conditions that exclude damage to the structures. The structures shall be placed on the pads.

Installation of steel structures shall be done predominantly by enlarged structural elements and blocks. Aggregated assembly of steel structures shall be performed at the storage sites or directly at the places of installation (in the area of the main installation mechanisms) depending on the degree of aggregation, as well as on the equipment of construction with mechanisms and vehicles.

Elements of steel structures shall be cleaned of dirt, ice, snow, earth, etc. before installation.

	Name	Signature	Date	<b>EN 406-BA</b>	Sheet	
Developer	Fatima-Z. M.					42
Sup-sor	Horb O.					

Working scaffolding and ladders required for the work of installers, as well as parts for securing the scaffolding and ladders shall be attached to the structures prior to their lifting.

The main elements of the steel structures which determine the geometric position of the structure (columns, frames, etc.) shall be installed immediately on the design axes and in the closest to the design position. The structures shall be securely fastened before releasing the hook of the crane.

All holes in the bolted mounting connections shall be filled with permanent bolts after installation of the structure. The number of washers on the permanent bolts must be no more than two (and at least one) under the nut and no more than one under the bolt head.

Instrumental verification of the proper installation of structures, as well as their final alignment and fixing shall be carried out immediately after the completion of the assembly of each unit of the structure in the sequence determined by the project.

## 5.2. Roofing works

Rolled roof is arranged with three layers of roofing felt. Gluing roll materials on the base material produced by mastics - hot or cold. The most widely used cold mastics.

Before gluing roll, roofs must prepare the base of the roof, process rolled material and prepare mastic. Preparation of the basis of the roof is the application of primer with brushes, nozzles or pneumatic guns. Ruberoid and other roll roofing materials with talcum powder on the surface before sticking should be cleared of it. Cleaning of rolled material from the powder is made with a solvent (green oil or kerosene), softening the coating layer on one side of the entire surface and on the other - the width of the overlap. Fine sprinkles are absorbed by the covering layer, while coarse sprinkles are easily cleaned with a spatula or knife. It is advisable to clean and rewind on the SOT-2 machine.

	Name	Signature	Date	<b>EN 406-BA</b>	Sheet
Developer	Fatima-Z. M.				43
Sup-sor	Horb O.				

Hot and cold mastics and primers are usually prepared centrally in factories and delivered to construction sites ready-made.

Gluing a mat of roll materials in all layers of coverage is carried out in one direction so that the seams of the sheets in adjacent layers were as far apart as possible. With a roof slope of less than 5% the lap width of the panels must be at least 100 mm in all layers.

Rolled bituminous materials (asphalt felt) are glued on the bituminous mastic. Hot bituminous mastic is used with a heat resistance of 75C.

Roofing with hot mastic is arranged in this sequence. Preliminary roll on the spot by rolling it dry with the application of a chalk line direction of the edge of the printed cloth for marking the place of application of mastic. After that, the panels are rolled up again.

Hot mastic poured on the surface and flatten with a toothed comb or roofing brushes for the entire width of the sheet and a length of not more than 500 mm. Mastic consumption should not exceed 1-2 kg/m<sup>2</sup>. When rolling on the surface covered with mastic, it is necessary to press the roll tightly and smooth the glued part from the middle to the edge. In the overlapping areas the material should be thoroughly smoothed with a comb or brush. After filling the seams, it is advisable to roll the carpet cylindrical, hand-held roller weighing 80-100 kg. For this purpose, use a special roller with electric heating, which during rolling heats the mastic, softens it and better compacts.

Places of roofing, the most exposed to wear and tear, and the joints of the sheets after gluing carpet additional hot mastic paste.

Particularly carefully perform sticking roll material in valleys, valleys and connections, with mastic applied to both the base and the roll material.

On slopes with a slope of 25 %, the material can be glued with a sticking machine. The roll is placed directly on the machine, rolled out and thereby lubricated with mastic as the machine moves. Pressing the roller to the roof, the roll is glued.

Feed mastic and rolls to the workplace roofers make a crane. For small

	Name	Signature	Date	<b>EN 406-BA</b>	Sheet
Developer	Fatima-Z. M.				44
Sup-sor	Horb O.				

amounts of work, hot bitumen is transported to the place of laying in a special thermos.

### 5.3. Flooring and finishing works

#### *Terrazzo flooring design.*

Before laying terrazzo coatings, the underlying floor structures are thoroughly cleaned and washed with water or cement mortar.

Terrazzo coatings do two-layer: the first layer - the bottom - the thickness of 15-20 mm of mortar with coarse sand on ordinary cement (mobility of cement mortar should correspond to immersion cone no more than 10 mm), the top layer - the front - from terrazzo on colored or ordinary cement with marble colored grain size 0.15-2 and 5-10 mm in different proportions.

Flooring begins with strengthening the pads on the prepared structural element of the floor. Then lay the bottom layer of the floor, compacting it with a trowel and rammer to the required thickness. Apply the top layer of the mortar before the first layer starts setting. After laying the front layer, it is compacted by the site vibrator, but carefully not to violate the pattern formed by the pads.

The next day after laying a layer of terrazzo create for 7-10 days the humidity regime. After the coating has acquired sufficient strength surface grinding the floor with a mosaic grinding machine.

Finishing work begins after the completion of installation work. Finishing walls made of hinged panels, perform monolithic, decorative plaster. Decorative plaster differs in texture and color. It is achieved by applying special mortars, normally colored, to the face layers. For this purpose, colored cements, marble flour and crumbs, mica and alkali-resistant pigments are used.

To apply the mortar to the surface it is necessary to cleanse it in advance from dust, dirt, fat and bituminous spots, efflorescence. If the surface is not rough it is notched, cut, blown with compressed air with sand.

After that you can apply the bottom layer of plaster up to 5-9 mm thick by spraying. For this use a mortar of increased consistency with increased

	Name	Signature	Date	<b>EN 406-BA</b>	Sheet
Developer	Fatima-Z. M.				45
Sup-sor	Horb O.				



content of the binder. After the mortar has hardened and the lower layer reliably binds to the base, level the surfaces. For that the primer - basic mortar with the thickness of 5-12 mm shall be applied. When plaster is more than 15-20 mm thick, layer-by-layer application is done - the second layer is applied after the first one has hardened. Each layer of primer is leveled, and before applying the face layer - before plastering, it is scraped. The upper, decorative layer is specially treated.

For the preparation of mortars, as well as mixing the finished use a cyclic mixer with a drum capacity of 110-250 liters, a capacity of 3-16 m<sup>3</sup> per shift.

For pumping mortars mortar pumps are used - diaphragm and plunger pumps. Solution is usually supplied to the workplace through mortar pipes - steel pipes or rubber hoses with diameter of 50-100 mm. Mortar channels must have revisions and dispensing cocks. Revisions are needed for cleaning, taps with nozzles - for connecting hoses. Apply the mortar through the nozzles. When using nozzles, the mortar, supplied through the channel, is picked up by the compressed air, supplied through the annular slots into the chamber of the nozzle, and is thrown out onto the plastered surface at high speed in a torch.

To carry out plastering work, means of assistance are required. Mobile and extendable scaffolding, scaffolding, as well as portable lightweight tables are used as scaffolding tools.

Plaster evenness is assessed by the condition of the face plane, linearity of whiskers, peaks, belts and eaves. Vertical deviation should not exceed 0.3% of the height of the room for improved plaster.

To ensure the necessary strength of the plaster, it is necessary to observe the curing time of the individual layers. When curing the plaster, do not let it dry out quickly and avoid drafts, plaster should be protected from getting wet, from freezing, from knocks and vibrations.

Suspended ceilings made of polyurethane foam on aluminum rails are used as ceilings. The frame, made of aluminum laths, is fastened to the floor

	Name	Signature	Date	<b>EN 406-BA</b>	Sheet
Developer	Fatima-Z. M.				46
Sup-sor	Horb O.				

slab with hangers. Hangers are connected to the floor slab with the help of dowels. The 400×400 mm panels are laid on the installed frame.

After the painting, the metal columns are clad with gypsum plasterboards, fastened to wooden grids of bars. Bars are attached to the column with self-tapping screws or bolts. The sheets are painted with paint rollers.

## 5.4. Environmental protection

When performing construction works on construction sites there is significant air pollution by dust and gaseous emissions (chlorvinyl, xylene). During repair and installation works, dust concentrations reach 44-150 mg/m<sup>3</sup> (increases as you get closer to the ground), during sandblasting works it reaches 180 mg/m<sup>3</sup>.

Motor vehicles operating in areas adjacent to construction sites saturate the first floors of buildings with average concentrations of ingredients exceeding the permissible concentrations of carbon monoxide by 3.1 times, nitrogen dioxide by 3.9 times, and dust by 1.7 times.

In order to reduce harmful emissions into the atmosphere in recent years, a number of measures have been developed, which must be strictly implemented at enterprises and construction sites. These measures include: maximum automation and mechanization of all loading and unloading operations in the process of processing of bulk raw materials, development and implementation of improved technological and transportation equipment, replacement of single-stage cleaning of dust, waste gases in cyclones with more efficient devices for fine dust collection.

Difficulties with arrangement of dust-cleaning facilities at the operating enterprises are connected with the fact that they require large production areas and are still ineffective.

At present, hydrodynamic vortex dust collectors are being introduced for removal of mechanical suspended matter from the air and for cleaning the gas flow. They can also be used to trap aerosols of paints, solvents and gases with

	Name	Signature	Date	<b><i>EN 406-BA</i></b>	Sheet
Developer	Fatima-Z. M.				47
Sup-sor	Horb O.				

high temperature. The captured dust precipitates at the bottom of the receiving tank in the form of a thick pulp and is removed from it by a scraper conveyor belt.

Another effective measure is to replace the wet cleaning system with electric filters, which remove up to 96.7% of dust from the air.

To control the dustiness of the air a device has been developed that measures the weight concentration of dust in the air IKP-1. The device is introduced into the practice of the sanitary-epidemiological stations.

The struggle against noise is one of the most important tasks on building objects. Noise not only has a harmful effect on people's health, but it also indirectly leads to an increase in injuries, and disturbs the natural exchange in the plant areas. Due to increased noise and vibrations, birds and animals leave their habitual places and vegetation begins to die out.

Sources of noise and vibrations in construction are transport-port facilities, earthworks machinery, compressors for sandblasters, caissons and vibration equipment, as well as the vibration equipment itself.

Maximum excess of noise norms is observed in the range of 500-4000 Hz and is 15-24 dB. Excavators, bulldozers, compressors have particularly high noise levels; the latter generates noise exceeding the limit by 7-17 dB at frequencies between 2000-3000 Hz.

When finishing works, parquet-splitting machines are intensive generators of noise, generating 10-21 dB noise intensity at workplaces, and up to 7-8 dB within the range of 1000-2000 Hz at a distance of 50 m.

The maximum dangers of vibrations are created when using different vibration machines and demolition hammers. Exceeding the norms is especially high in the area of frequencies up to 500 Hz. Maximum vibrations, general and local, exceeding the norms by 5-17 times in the frequency ranges of 30-1000 Hz, are observed at bulldozers and excavators.

The currently available noise and vibration control means and techniques make it possible in most cases to reduce noise and vibration below

	Name	Signature	Date	<b>EN 406-BA</b>	Sheet
Developer	Fatima-Z. M.				48
Sup-sor	Horb O.				

the sanitary standards, but this is due to the lack of attention to this problem in construction.

The measures against the noise produced by the machines are damping, replacement of the material of the parts, arrangement of the covers, achievement of the minimum tolerances in the joints of the parts and quality maintenance, as well as reduction of the number of earthworks and development of the technology of cast self-compacting concretes.

It is more difficult to combat the intensity of traffic noise, reaching 50-62 dB at the level of the first floors. Particularly significant noise impact falls on the share of heavy-duty vehicles with trailing devices.

Noise during finishing works is significantly reduced by internal and external shielding.

Planning work to be carried out only in the area specified in the project, trying to locate the storage areas. If there is a need to use additional areas of the natural landscape for storage or storage of parts, it is advisable to replace the leveling of sites, adopted in the construction, with inventory leveling structures or made on site with the provision of ventilation of the ground surface.

Access roads to storage areas shall be located on the side of the building area. Laying of transport routes for construction should generally coincide with permanent roads and driveways.

At the beginning of the development of the construction site it is necessary to strictly monitor the removal of the topsoil from the entire area to be built up and subject to planning work for its further use in the improvement of the construction site or for sending to other areas. Soil dumps must not be backfilled with tree boles, as most species die from this.

Laying of underground utilities should be carried out strictly according to the project, taking into account that the zone of harmful effects of various conductors on plants and the opposite impact extends to 100 m, which must be specified in the project.

	Name	Signature	Date	<b>EN 406-BA</b>	Sheet
Developer	Fatima-Z. M.				49
Sup-sor	Horb O.				

When erecting the above-ground part of the building, in addition to the environmental protection measures mentioned above, care must be taken to protect the internal environment in the rooms of the future building. Particular attention should be paid to the quality of filling construction joints, because the poor quality of filling them dramatically increases the sound transmission of internal enclosures (partitions and ceilings), as well as suffering heat and oxygen conditions of the premises, violated by the penetration of air through the poorly sealed joints of the floor. The quality of the fitting of the door and window panels to the frames, as well as the sealing of the window and door glazing have a major impact on reducing the sound transmission of the enclosures.

During the curtailment of construction work, all construction waste must be removed from the area to be improved for further disposal. In no case should you make "burial" of defective prefabricated elements, especially in the horizontal position, as it disturbs the groundwater. It is prohibited to incinerate all burnt waste so as not to pollute the air space of the city.

The natural bodies of water left within the boundaries of the development must not be littered with construction waste, and in the projected cleaning of their bottoms, their natural water retention cover must not be disturbed.

When completing landscaping and planting of greenery, the number of asphalt pavements shall be reduced, all intra-block and park paths shall be covered with water-permeable materials as far as possible. Planting of greenery shall be carried out within the specified time frame and under the supervision of specialists.

	Name	Signature	Date	<i><b>EN 406-BA</b></i>	Sheet	
Developer	Fatima-Z. M.					50
Sup-sor	Horb O.					