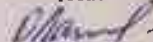

MINISTRY OF EDUCATION AND SCIENCE OF UKRAINE
NATIONAL AVIATION UNIVERSITY
FACULTY OF ARCHITECTURE, CIVIL ENGINEERING AND DESIGN
COMPUTER TECHNOLOGIES OF AIRPORT CONSTRUCTION AND
RECONSTRUCTION DEPARTMENT

TO ADMIT TO GUARD

Head of the Department

 O.I. Lapenko

8 » 06 2022

BACHELOR THESIS

(EXPLANATORY ACCOUNT)

SPECIALTY 192 «BUILDING AND CIVIL ENGINEERING»

Educational and professional program: «Industrial and civil engineering»

Theme: «Industrial building in Gostomel city of Kyiv region»

Performed by: student of group ЦБ – 406 Ба, Ayoub Kyrolos

Thesis Chair: Doctor of Engineering Sciences, Professor Hasii, H.M.

Design rule check:  O. Rodchenko

Kyiv 2022

МІНІСТЕРСТВО ОСВІТИ І НАУКИ УКРАЇНИ
НАЦІОНАЛЬНИЙ АВІАЦІЙНИЙ УНІВЕРСИТЕТ
ФАКУЛЬТЕТ АРХІТЕКТУРИ, БУДІВНИЦТВА ТА ДИЗАЙНУ
КАФЕДРА КОМП'ЮТЕРНИХ ТЕХНОЛОГІЙ БУДІВНИЦТВА ТА
РЕКОНСТРУКЦІЇ АЕРОПОРТІВ

ДОПУСТИТИ ДО ЗАХИСТУ

Завідувач випускової кафедри

 О.І. Лапенко

« 8 » / 11 2022 р.

ДИПЛОМНА РОБОТА
(ПОЯСНЮВАЛЬНА ЗАПИСКА)
ВИПУСКНИКА ОСВІТНЬОГО СТУПЕНЯ БАКАЛАВР
ЗА СПЕЦІАЛЬНІСТЮ 192 «БУДІВНИЦТВО ТА ЦИВІЛЬНА
ІНЖЕНЕРІЯ»
ОСВІТНЬО-ПРОФЕСІЙНА ПРОГРАМА
«ПРОМИСЛОВЕ І ЦИВІЛЬНЕ БУДІВНИЦТВО»

Тема: «Виробнича будівля в смт Гостомель Київської області»

Виконавець: ЦБ – 406 Ба, Аюуб Кіролос Аніс Шакер
(студент, група, прізвище, ім'я, по батькові)

Керівник: д.т.н., доц. Гасій Г.М.
(науковий ступінь, вчене звання, прізвище, ім'я, по батькові)

Нормоконтролер:  Родченко О.В.
(ПІБ)

Київ 2022

НАЦІОНАЛЬНИЙ Авіаційний університет
Факультет архітектури, будівництва та дизайну
Кафедра комп'ютерних технологій будівництва та реконструкції аеропортів
Спеціальність: 192 «Будівництво та цивільна інженерія»
Освітньо-професійна програма: «Промислове і цивільне будівництво»

ЗАТВЕРДЖУЮ

Завідувач кафедри

[Підпис] О.І. Лапенко
«13» / 04 2022 р.

ЗАВДАННЯ
на виконання дипломної роботи

Аюуб Кіролос Аніс Шакер
(І.І.Б. випускника)

1. Тема роботи «Виробнича будівля в смт Гостомель Київської області» затверджена наказом ректора від «13» квітня 2022р. № 379/ст.
2. Термін виконання роботи: з «23» травня 2022р. по «19» червня 2022р.
3. Вихідні дані роботи: одноповерхова виробнича будівля зі сталевим кроквяними конструкціями, стіновими панелями та труботонними стійками, навантаження відповідно до ДБН В.1.2-2:2006 «Навантаження та впливи».
4. Зміст пояснювальної записки:
Вступ, аналітичний огляд, архітектурно-планувальна частина, розрахунково-конструктивна частина, технологічно-організаційна частина, висновки, список використаних джерел.
5. Перелік обов'язкового ілюстративного матеріалу: таблиці, рисунки, діаграми, графіки не менше 4-х креслень та 4-х слайдів:
 - фасади, план типового поверху, експлікації
 - креслення конструкції, специфікації елементів
 - технологічно-організаційні схеми виконання основних будівельних процесів

6. Календарний план-графік

№ з/п	Завдання	Термін виконання	Підпис керівника
1.	Аналітичний огляд	13.05.22-14.05.22	<i>Гасій</i>
2.	Архітектурно-будівельний розділ	16.05.22-20.05.22	<i>Гасій</i>
3.	Розрахунково-конструктивний розділ	23.05.22-02.06.22	<i>Гасій</i>
4.	Технологічно-організаційна частина	03.06.22-04.06.22	<i>Гасій</i>
5.	Вступ. Висновки. Список використаних джерел.	06.06.22-07.06.22	<i>Гасій</i>
6.	Підготовка доповіді та презентації	08.06.22-11.06.22	<i>Гасій</i>

8. Дата видачі завдання: «13» травня 2022 р.

Керівник дипломної роботи:

Гасій

Гасій Г.М.

Завдання прийняв до виконання:

Аюуб

Аюуб Кіролос Аніс Шакер

CONTENTS

INTRODUCTION	5
CHAPTER 1. ANALYTICAL REVIEW	6
CHAPTER 2. ARCHITECTURAL DESIGN	9
2.1. Site characteristics	9
2.2. Vertical planning and landscaping	10
2.3. Architectural and planning decisions.....	11
2.4. Constructive solutions	11
2.6. Special events and works	14
2.7. Thermal calculation of the enclosing structure	16
CHAPTER 3. STRUCTURAL DESIGN.....	19
3.1. Load calculation	19
3.2. Calculation of column.....	21
CHAPTER 4. TECHNOLOGY OF CONSTRUCTION	28
4.1. Field of application	28
4.2. Characteristics of structures to be installed	28
4.3. The structure of the complex process and the scope of work.....	29
4.4. Selection of mounting cranes and cargo-lifting devices.....	30
4.4.1. Selection of cargo-lifting devices.	30
4.4.2. Specify mounting parameters.	31
4.4.3. Choice of vehicles.....	33
4.5. Organization and technology of work.....	34
4.6. Requirements for the quality of work	35
4.7. Calculation of labor costs and machine time	37

4.8. Schedule of work37

4.9. The need for material and technical resources.....38

4.10. Safety and labor protection39

4.11. Technical and economic indicators.....42

CONCLUSIONS.....43

REFERENCES.....48

INTRODUCTION

Over 80% of industrial buildings are built in a one-story design. There is the common practice of metal structures for immense spans, mainly in buildings of a great area.

Structural explanations for roof systems of buildings are distinguished by a large number of junction points of elements, then, the laboriousness of arrangement of separate elements of the roof, especially their connection and fixing, is high. In addition, element-by-element roof setting up goes into the category of climbing and the most unsafe work, and work is usually achieved slowly. The present tendency to place engineering infrastructures, and equipment in the inter-farm space led to an additional increase in the complexity of the construction of the roof structure.

The difficulty of manufacturing roofing for buildings is 75% of the total labor intensity of the construction, hence, the achievement time of construction also be subject to the period of installation of the roof structure.

The prevalent use of structural and large-block roofs typically rejects element-by-element setting up, since roofs are completely composed on the level and then can be elevated to the design position as the finished blocks.

For comparison, a block of 12 by 24 m in metal weighs up to 40 tons, and the mass of prefabricated reinforced concrete structures for the same is up to 3 times more. The constructive design of blocks in steel makes it possible to recklessness heavy strengthened concrete trusses and floor slabs.

Unit gathering with the steel decking and insulation made it probable to collect roofing units with an advanced construction willingness and a mass matching to the lifting cranes.

CHAPTER 1. ANALYTICAL REVIEW

At present-day, the furthestmost important unruly is the development of metropolises in area and density of building, exclusively for rising settlements with an in-height populace mass in the areas furthestmost good-looking for building.

The resulting main explanations uttering the requirement for recovery of industrial buildings can be recognized: inconsistency amid the standing planning structure and growing supplies, as well as newfangled meanings and burdens on the municipal location; outmodedness and lessening in appealing and practical pointers of inner-city structures; ethical and physical evaluation of the building; unsatisfactory productivity in the practice of municipal ranges.

Renewal of industrial structures is becoming the best technique to solve the problems of prevailing urban expansion and the chance of reorientating fallow industrial buildings to expand activities by rotating the workshop area into an up-to-the-minute residential multipart, supermarket run, place of work, and performing hubs.

The foremost approaches to renewal are applications – which include the formation of an untruthful frontage as pullouts or edges that transform the plasticity of the facades of standing industrial buildings; redesign – which includes a fundamental transformation in the peripheral attendance of the building and finding a linking with the location; integration – includes inserting elements and structures into standing structures to produce a three-dimensional configuration. The core arrangements for the adaptation of industrial buildings and grounds are the housing of budget class, well-being

class, and quality housing; parking lots entertainment facilities; supermarket; game halls, etc.

Let's consider numerous categories of space-planning designs for industrial buildings characteristic of the urban as well as methods of current building:

- One-story industrial buildings can be made up 50% of the entire quantity of industrial buildings in the city. The column arrangement is typically six meters, the span is subject to the distance of the beams or trusses and is regularly a variety of three meters. The main rewards are the straightforwardness of the project, large single-level areas, easy entry, and spacious layout. The shortcomings contain the great budgets of the area and the span of engineering systems.
- Strengthened concrete multi-story frame. Multi-story industrial buildings in the city involve manufactured strengthened concrete elements with a matrix of columns $6 \times 9 \text{ m}$ with floor masses up to 20 kN/m^2 and $6 \times 6 \text{ m}$ with floor masses up to 25 kN/m^2 , with a floor height of 7.5 m , the number of floors is two to six and the number of spans is two or more. Reliant on the type of floorings, the structure of the building can be beamed and beamless.

Numerous structural elements of industrial conveniences can be renovated and used for new goals in a reconstructed building. Ventilation systems in industrial buildings are usually attached, they are easy to dismantle, upgrade or remake, and after reconstruction, they can be used as specialized ventilation systems, and hoods for rooms with completely different temperature and humidity conditions.

It is also possible to convert and use in new conditions and engineering systems of water supply, sewerage, electricity, and heating. The use of wide-span trusses, arches, and beams makes it possible to place auxiliary technical floors and additional equipment in the inter-beam, inter-arch, and inter-truss space, be it ventilation systems, power supply systems, and others.

CHAPTER 2. ARCHITECTURAL DESIGN

2.1. Site characteristics

The land plot for the construction of a repair and mechanical workshop is located at a sanitary distance from the residential buildings in the Gostomel city of Kyiv region.

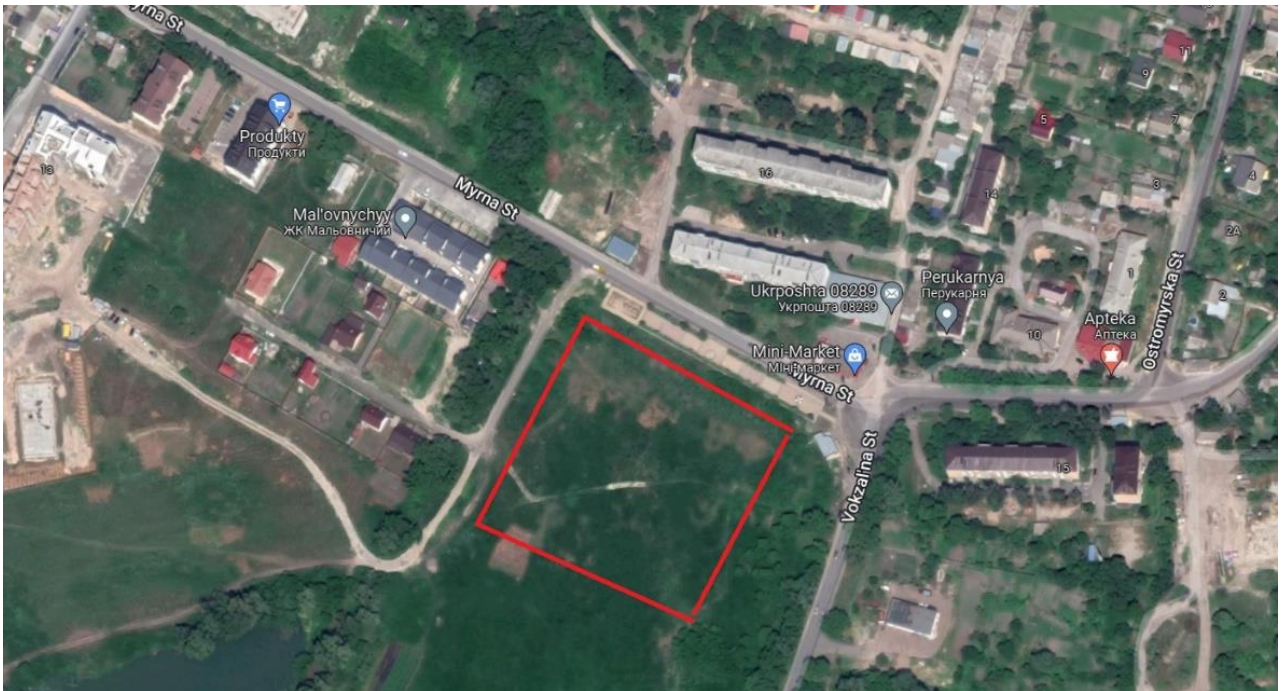

Fig. 2.1. situational plan

The master plan envisages the rational placement of the repair and mechanical workshop on the part of the metering and parting unit free from technological equipment.

Surface water drainage is designed of open type and is carried out by planned planes and trays.

The construction site has a rectangular shape with a branch and is located in the area of the field.

The plot has an area of 11 hectares and a uniform slope from east to west.

The project of vertical planning of the location is advanced on the principle of thoroughgoing preservation of the prevailing relief taking into account hydrogeological landscapes, architectural and planning conclusions of the projected building, and the necessities of regulatory documents.

The position of the building on the site, taking into account its amount of stories, does not violate regulatory necessities for the insolation of neighboring buildings.

To ensure sanitary and hygienic necessities, as well as the normal movement of vehicles and walkers, the fixing of gravel, gravel, and bitumen pavement on driveways and sites. The design of the pavement is created on the intensity of traffic.

2.2. Vertical planning and landscaping

The plan of the organization of a relief of a site under construction is advanced taking into account existing marks of relief of adjoining grounds. Drainage of the stream and melt water from the location is supported superficially, towards the natural fall of the terrain.

The principal plan is made taking into account the standing buildings, traffic conditions, and walkers.

Planning marks are accepted taking into account the opportunity of suitable and safe passes of transport, and ordinary slopes.

The maximum preservation of existing landscaping is expected. Travel to the repair shop is done with asphalt pavement.

Throughout the rest of the field, the driveways are made of gravel, and pedestrian paths are gravel.

2.3. Architectural and planning decisions

In the exterior decoration, modern finishing materials are used, and modern metal-plastic windows with double-glazed windows are installed.

The architectural planning and three-dimensional decision of the repair and mechanical workshop were determined founded on the local situation, the size of the land, and the directing distances to the present buildings.

For the ease of staff in front of the key entrance to the building is a place for temporary parking. For quality recreation during the break next to the building is a recreation area with minor architectural arrangements.

The structure of the building is designed as a frame, with one span of columns and a roof of steel trusses.

Facade elements are numerous with the application of up-to-date design attainments.

2.4. Constructive solutions

Rigidity is guaranteed by the combined behavior of tubular steel-concrete columns, steel trusses, and horizontal and vertical links.

The building is considered to use individual steel and tubular manufactured structures of columns and trusses.

The constructive is solved by one span of 18 m from a framework with two rows of tubular steel-concrete columns with support on them of steel trusses of a covering located with a step of 6 m.

The building of the repair and mechanical workshop is considered as a one-story frame one-span with walls of hinged three-layer panels.

The key goal of the foundations is the allocation of loads from the building to the foundation. Taking into account the characteristics of the soil

of the construction site grounded on technical and economic analysis of the foundations adopted a shallow foundation monolithic glass type with manufactured reinforced concrete foundation beams under the outer walls. The depth of the foundations is 1.5 m.

Partitions between individual sections are considered with a thickness of 100 mm from a steel frame lined with steel sheets.

External walls from the conditions of heat engineering are accepted from three-layer sandwich panels 300 mm thick.

The roof is premeditated from three-layer sandwich panels with a thickness of 0.300 m, which are laid on the scaffolding of steel girders from the channel №8, laid on the upper belt of trusses with a step of 1.500 m.

The roof is considered from steel trapezoidal trusses with a height of 2.400 m from two equal-shelf corners of individual manufacture. Roof trusses are created on individually made tubular steel-concrete columns. The choice of the type of columns is made grounded on technical and economic analysis of different sorts of columns.

Exterior finishing of the building is performed following the passport of external finishing.

The inner ornamentation of the rooms is achieved giving information about finishing works.

Door leaves, heaters, and tubes are painted with enamel paint twice.

Filling of window and door openings. The natural illumination of the building is provided by window openings.

Metal elements are to be treated with black varnish 2 times.

The project envisages the installation of metal-plastic window blocks with double glazing. The closure of metal-plastic window blocks is approved using self-tapping screws before scaffolding on steel-concrete columns. The seams between the window blocks and the walls are filled with spume.

Door leaves are fixed on two hinges. The building has steel and plastic-wooden doors considered. All doors are made deaf. Door frames are devoted with self-tapping screws to the scaffolding on the wall frame. The seams between the door frames and the outer walls are filled with spume.

Due to the non-aggressiveness of the air environment, the protection of strengthened concrete structures is not provided.

Protection of building structures from corrosion.

Protection of interior and outside metal structures is provided by two times oil paintings.

The walls at the bottom of the window openings are covered with galvanized steel drains. Defense of structures from the outside effect of the air is reduced to protection from precipitation.

Guard of entrenched parts as anchors and other metal elements unseen in the structures under construction is achieved by covering with a cement-polymer layer.

Heating networks – the source of supply - heat generator in the existing operator building. The heat carrier is water with parameters 95° – 70° . Heat network from steel pipes.

Ventilation of premises is accepted supply and exhaust mechanical and natural.

The project adopts underground duct laying of thermal networks in impassable strengthened concrete trays unconnectedly for heating and hot water supply.

The source of the water supply of the repair shop is the current water supply system with a diameter of 50 mm.

The internal sewerage network is made of cast iron sewer pipes. External sewerage networks are laid from ceramic sewer tubes with a diameter of 150 mm to biological treatment plants.

Outside networks are considered from cast iron pressure tubes. Wells on the network are made of produced strengthened concrete elements.

The inside water supply system is made of light steel water pipes.

The project provides for the following types of communication and signaling:

- district telephone communication;
- radio broadcasting;
- automatic fire alarm.

2.6. Special events and works

Explosion and fire safety measures. The projected building belongs to the II degree of fire resistance and is located in an explosion and fire zone.

The quality of materials used for concrete work in winter is subject to systematic control by laboratory tests.

Measures related to construction in special conditions. Manufacture of monolithic foundation and concrete floor screed should be achieved with the use of antifreeze additives.

The following explosion and fire safety measures are provided:

- in the building of the II degree of fire-resistant roofs that do not burn are applied;
- emptying from premises is supported out on two evacuation exits;
- the building is provided with fire engines at a distance of not less than 5 m and not more than 8 m;
- access to the roof is carried out by an external metal ladder.

Water supply to the network is provided by a pumping station for firefighting, located in the building of its fire station.

Interior fire extinguishing is provided by two fire hydrants with a production of 5 l / s.

Outside firefighting is provided by fire hydrants, which are installed on the fire water supply network.

If the fire is extinguished for 3 hours, the water consumption will be 173 m³.

The following measures are envisaged for environmental protection:

- watering of green plantings is carried out from the existing watering cranes which are established in niches of a socle of the next operator's building;
- landscape gardening of the construction site: the existing green areas are preserved as much as possible, new ornamental shrubs are planted, and perennial grasses are sown. To reduce dust and sound, gravel roads and sidewalks near the workshop building have been designed. The project envisages cutting the fertile layer 0.50 m thick. Vertical planning solved the drainage of stormwater runoff;
- the projected building is prepared with a centralized water supply, heat supply, and sewerage;
- to reduce the level of household noise and vibration from the operation of electric motors and equipment in engineering systems, when performing construction and installation work should pay attention to the careful implementation of sound and vibration insulation requirements specified in the project.

The following environmental defense measures are envisaged for the construction period:

- construction waste is taken to the landfill, and burying it on the construction site is prohibited;
- contamination of the fertile layer with paints and solvents is not allowable;
- when performing construction and installation works, the requirements for preventing dust and air pollution should be observed;
- measures are taken to avoid air pollution. All machinery operating on the construction site must be verified for exhaust toxicity;
- mechanisms are prohibited.

2.7. Thermal calculation of the enclosing structure

The construction of a wall delivers the existence of a steel profile sheet 20 mm thick on both parties of a heater.

Subsequently, steel has high thermal conductivity and serves as a bridge of cold in the outer walls of the buds, the thermal calculation of the outer wall is accepted as a single-layer structure of insulation.

Insulation made of extended polystyrene extrusion plates with a thickness of 260 mm is arranged between the inner and outer profile sheet (Fig. 2.2).

The project foresees the next constructive for the outside wall of the building – three-layer industrial hinged sandwich panels with insulation from expanded polystyrene extrusion plates with a mass of 80 kg/m³.

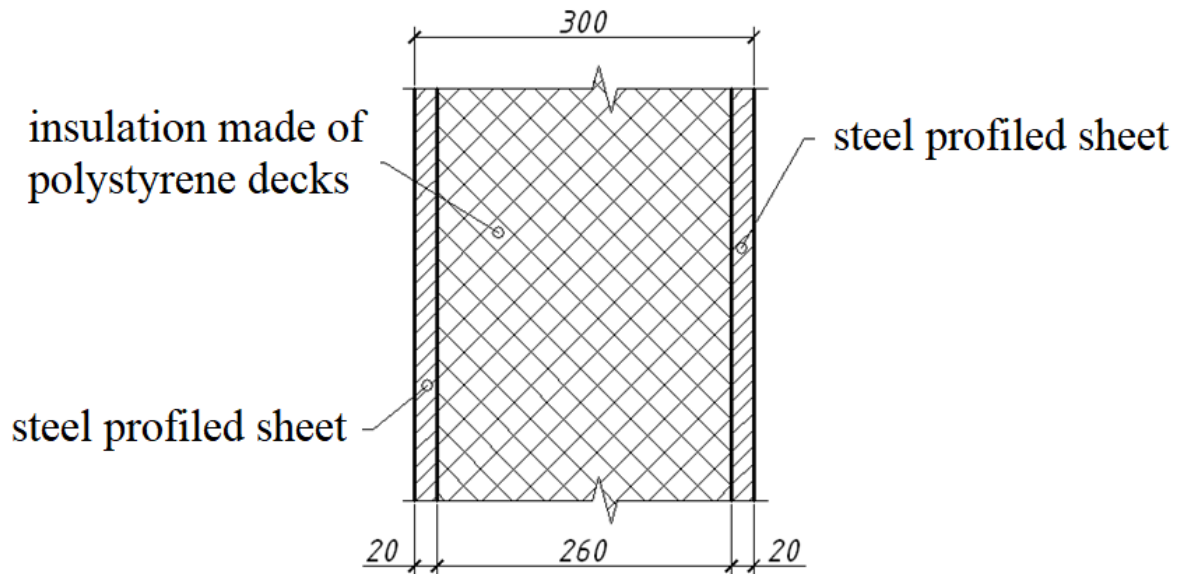

Fig. 2.2. Exterior wall construction

The minimum allowable value, R_{qmin} heat transfer resistance of the enclosing structures of an industrial building. In this case, this value is $R_{qmin} = 2.0 \text{ m}^2\text{K}/\text{W}$.

In turn, the thermal resistance of homogeneous fencing structures, or a separate layer of multilayer fences is determined by the formula:

$$R = \frac{\delta}{\lambda} \quad (2.1)$$

where δ – the thickness of the layer, m,

λ – the coefficient of thermal conductivity of the material, $\text{W}/(\text{m}^2\text{K})$.

Estimated characteristics of the wall structure: density $\rho = 80 \text{ kg}/\text{m}^3$, thickness $\delta = 0.26 \text{ m}$, thermal conductivity $\lambda = 0.041 \text{ W}/(\text{m}^2\text{K})$.

Heat transfer resistance of thermally homogeneous, multilayer, opaque enclosing structure is calculated by the formula:

$$R_{\Sigma} = \frac{1}{\alpha_B} + \sum_{i=1}^n \frac{\delta_i}{\lambda_{ip}} + \frac{1}{\alpha_3} \quad (2.2)$$

where α_B, α_3 – heat transfer coefficients of the inner and outer surfaces of the enclosing structure, $W/(m^2K)$.

Respectively

$$\alpha_B=8,7 \text{ W}/(m^2K), \alpha_3=23 \text{ W}/(m^2K).$$

λ_{ip} – thermal conductivity of the material of the i –th layer of the structure in the calculated operating conditions.

Write the formula following the design solution of the enclosing structure and obtain:

$$R = 1/\alpha_B + \delta/\lambda + 1/\alpha_3 \quad (2.3)$$

Substituting the corresponding values was obtained:

$$R = 1/8.7 + 0.26/0.041 + 1/23 = 0.115 + 6.342 + 0.043 = 6.5 \text{ m}^2K/W$$

Thus, the calculated value of the heat transfer resistance of the accepted wall structure exceeds the normative value, so this wall structure fully satisfies the requirements of thermal insulation.

CHAPTER 3. STRUCTURAL DESIGN

3.1. Load calculation

The calculation of loads per 1 m^2 of the floor is summarized in table 3.1.

Installation of the estimated span of the plate. When resting on the floor walls, the estimated span:

$$l = 6.3 - 0.12 - 0.17 = 6.01 \text{ m.}$$

Table 3.1

Characteristic and design load per 1 m^2 of floor

Load	Characteristic load N/m^2	Load reliability factor γ_{fm}	Estimated load, N/m^2
Constant: Own weight of a multi-hollow slab with round cavities	3000	1.1	3300
Also, a layer of cement mortar $\delta = 30\text{mm}$, ($\rho = 2200 \text{ kg/m}^3$)	660	1.3	858
Also, ceramic tiles, $\delta = 13 \text{ mm}$, ($\rho = 1800 \text{ kg/m}^3$)	240	1.1	264
Total	3900	—	4422
Variable load	2000	1.2	2400
Full load	5900	—	6822

Estimated load per 1 m with a slab width of 1.5 m , taking into account the reliability factor for the building $\gamma_n=1$:

– constant load:

$$g = 4.422 \cdot 1.5 \cdot 1 = 6,633 \frac{kN}{m};$$

– characteristic load:

$$g + v = 6.822 \cdot 1.5 \cdot 1 = 10,233 \frac{kN}{m};$$

$$v = 6.0 \cdot 1.5 \cdot 1 = 9.0 \frac{kN}{m}.$$

Characteristic load per 1 m:

– constant load:

$$g = 3.9 \cdot 1.5 \cdot 1 = 5.85 \text{ kN/m};$$

– full load:

$$g + v = 5.9 \cdot 1.5 \cdot 1 = 8.85 \text{ kN/m};$$

Forces from design and characteristic loads.

From the design load

$$M = (g + v) \frac{l_0^2}{8}, \quad (3.1)$$

where $-(g + v)$ – full load, kN/m;

l_0 – estimated span, m

$$M = 6.822 \frac{6.01^2}{8} = 30.8 \text{ kNm};$$

$$V = (g + v) \frac{l_0}{2}, \quad (3.2)$$

$$V = 6.822 \frac{6.01}{2} = 20.5 \text{ kN}$$

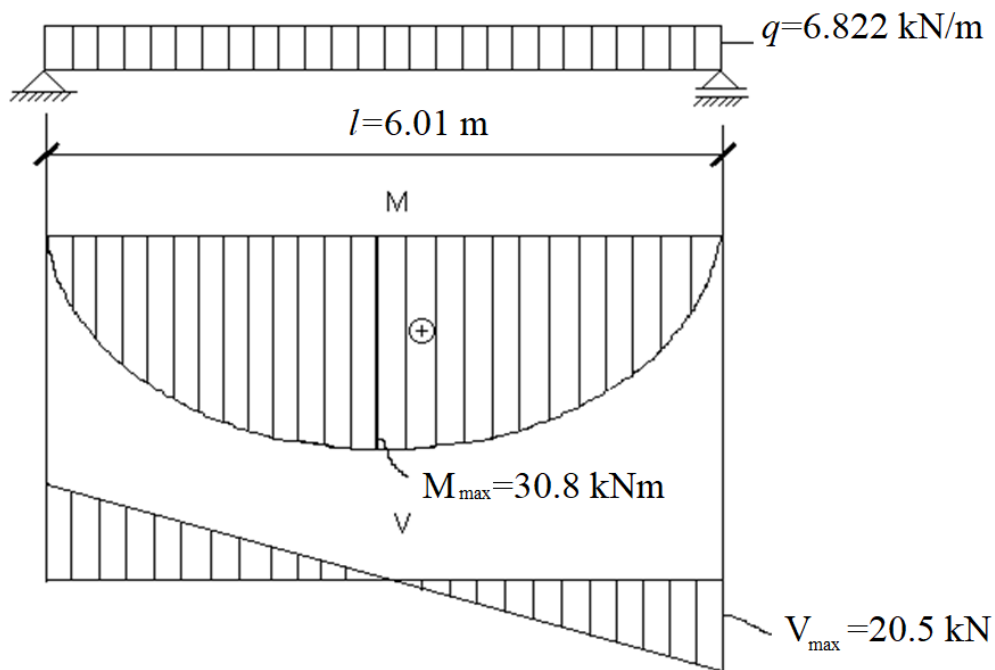

Fig. 3.1. Determination of design forces M and V

From the characteristic full load:

$$M = 5.9 \frac{6.01^2}{8} = 24.05 \text{ kNm};$$

$$V = 5.9 \frac{6.01}{2} = 16.84 \text{ kN}$$

From characteristic constant and long loadings:

$$M = 15.0 \frac{6.01^2}{8} = 76.3 \text{ kNm}$$

3.2. Calculation of column

The following data are taken in the design:

Pipe parameters:

– pipe wall thickness

$$t_p = 0.8 \text{ cm} = 0.8 / 100 = 0.008 \text{ m};$$

– outer diameter of the tube

$$D_p = 32.5 \text{ cm} = 32.5 / 100 = 0.325 \text{ m};$$

Effort:

– axial force

$$N = 34.97626 / 101.97162123 = 0.343 \text{ MN};$$

– bending

$$M = 5.20055 / 101.97162123 = 0.051 \text{ MN m};$$

Characteristics of steel tube:

– temporary resistance of steel tube rupture 370 MPa ;

– estimated resistance of steel shift 124 MPa ;

– calculated resistance to stretching, compression, and bending by temporary resistance of steel tube 350 MPa ;

– the limit of the fluidity of steel tube 225 MPa ;

– estimated resistance of steel tubes stretching, compression, and bending beyond the flow rate of 215 MPa ;

Reliability ratio and working conditions:

– reliability ratio in calculations on temporary resistance is 1.3.

– coefficient of concrete working conditions, taking into account the influence of additional factors is 1;

Characteristics of concrete:

– concrete class C20/25.

– heavy concrete;

The normative value of concrete resistance axial compression is 18.5 MPa .

The estimated resistance of concrete axial stretch is taken at 1.05 MPa .

Estimated concrete resistance axial compression 14.5 *MPa*.

The normative value of concrete resistance axial stretch is 1.55 *MPa*.

The radius of the concrete core:

$$r_b = (D_p - 2 t_p) / 2 = (0.325 - 2 \cdot 0.008) / 2 = 0.1545 \text{ m} = 15.45 \text{ cm}.$$

Concrete core diameter:

$$D_b = 2 r_b = 2 \cdot 0.1545 = 0.309 \text{ m} = 30.9 \text{ cm}. \quad (3.3)$$

The area of the cross-section of the metal pipe:

$$\begin{aligned} A_p &= p / 4 (D_p^2 - D_b^2) = 3,14159 / 4 \cdot (0,325^2 - 0,309^2) = \\ &= 79.7 \text{ cm}^2. \end{aligned} \quad (3.4)$$

The estimated resistance of the metal pipe at a single-axis stress state is 215 *MPa*.

The calculated value of concrete resistance axial stretch for the boundary states of the second group is 1.55 *MPa*.

Concrete strain module, which is obtained depending on the duration of the load and taking into account the presence of cracks: $E_{bI} = 0.85 E_b = 25500 \text{ MPa}$.

The moment of inertia of the concrete section relative to the center of gravity of the given cross-section:

$$\begin{aligned} I &= p (D_p - 2 t_p)^4 / 64 = \\ &= 3,14159 \cdot (0,325 - 2 \cdot 0,008)^4 / 64 = 44751.1 \text{ cm}^4 \end{aligned} \quad (3.5)$$

Moment of inertia of the pipe section:

$$\begin{aligned} I_p &= p (D_p^4 - (D_p - 2 t_p)^4) / 64 = \\ &= 3,14159 \cdot (0,325^4 - (0,325 - 2 \cdot 0,008)^4) / 64 = 10013.9 \text{ cm}^4 \end{aligned} \quad (3.6)$$

The moment of inertia of the given section of the element relative to its center of gravity:

$$\begin{aligned} I_{red} &= I + I_p a_p = \\ &= 0.000447511 + 0.000100139 \cdot 8.07843 = 126,000 \text{ cm}^4 \end{aligned} \quad (3.7)$$

Coefficient of bringing the steel pipe to concrete:

$$a_p = E_p / E_{b1} = 206000 / 25500 = 8,07843 \quad (3.8)$$

The area of the given cross-section:

$$A_{red} = A_b + A_p a_p = 0.07499 + 0.00797 \cdot 8.07843 = 0.13938 \text{ m}^2 = 1393.8 \text{ cm}^2$$

The greatest stresses of stretching in concrete:

$$\begin{aligned} s_{bt, \max} &= -N / A_{red} + M / I_{red} (D_p - 2 t_p) / 2 = \\ &= -0,343 / 0,13938 + 0,05162 / 0,00126 \cdot (0.325 - 2 \cdot 0.008) / 2 = \\ & \quad 3.8687 \text{ MPa} \end{aligned} \quad (3.9)$$

The radius of energy of the given cross-section:

$$i_{red} = \sqrt{I_{red} / A_{red}} = \sqrt{0,00126 / 0,13938} = 9,51 \text{ cm}. \quad (3.10)$$

Since $s_{bt, \max} = 3.8687 \text{ MPa} > R_{bt, ser} = 1.55 \text{ MPa}$, then cracks are formed.

Concrete section inertia moment relative to the center of gravity of the given section

$$I = p (D_p - 2 t_p)^4 / 64 = 3.14159 \cdot (0,325 - 2 \cdot 0,008)^4 / 64 = 44751.1 \text{ cm}^4$$

The moment of inertia of the given section of the element relative to its center of gravity:

$$I_{red[p]} = a_b[p] I + I_p = 10013.9 \text{ cm}^4$$

The area of casting the cross-section of the element:

$$A_{red}[p] = ab[p] A_b + A_p = 79.7 \text{ cm}^2$$

The radius of energy given to the metal pipe section:

$$i_{red}[p] = \sqrt{I_{red}[p] / A_{red}[p]} = \sqrt{0,000100139 / 0,00797} = 11,21 \text{ cm}. \quad (3.11)$$

Longitudinal eccentricity relative to the center of gravity of the given section
 $e_o = M/N = 0.051 / 0.343 = 0.14869 \text{ m} = 14.87 \text{ cm}.$

Random eccentricity:

$$e_a = \max (l/600; D_p/30; 0.01) = \max (4/600; 0.325/30; 0.01) = 0.01083 \text{ m} = 1.08 \text{ cm}.$$

For elements of statically uncertain structures, the value of the eccentricity of the longitudinal force relative to the center of gravity of the given cross-section is taken equal to the value of eccentricity obtained from the static calculation, but not less than e_a .

Next, the estimated length of the non-center-compressed element is determined. It is accepted that the element is with a malleable hinge sawing at one end, and at the other with rigid laying.

The continuation of the calculation is carried out, since $l_o/i_{red} = 6/0.11209 = 53.52841 > 12$.

The estimated length of the element $l_o = 1.5 l = 1.5 \cdot 4 = 6 \text{ m} = 600 \text{ cm}.$

The moment relative to the center of the most stretched or least compressed rod from the action of constant and prolonged loads:

$$\begin{aligned} M_l l &= abs (M_l) + N_l r_s = abs (0.05162) + 0.343 \cdot 0.2 = \\ &= 0.12022 \text{ MN m} \end{aligned} \quad (3.12)$$

The moment relative to the center of the most stretched or least compressed rod from the full load:

$$M_l = abs(M) + N r_s = abs (0.051) + 0.343 \cdot 0.2 = 0.1196 \text{ MN m} \quad (3.13)$$

Coefficient taking into account the impact of the duration of the load:

$$f_l = 1 + M_{l1}/M_1 = 1 + 0,12022/0,1196 = 2,00518 \quad (3.14)$$

Factor:

$$d_e = e_o/D_p = 0,14869/0,325 = 0,45751.$$

$$k_b = 0,15 / (f_l (0,3 + d_e)) = 0,15 / (2 \cdot (0,3 + 0,45751)) = 0,09901.$$

$$k_s = 0,7.$$

Eccentricity:

$$e = e_o = 0.14869 \text{ m} = 14.87 \text{ cm}.$$

Since

$$(1 - 7.5 e / (D_p - 2 t_p)) = (1 - 7.5 \cdot 0.14869 / (0.325 - 2 \cdot 0.008)) = -2.60898 < 0,$$

then the calculated resistance of concrete during compression in the composition of the pipe-concrete element 215 MPa.

Bending stiffness:

$$\begin{aligned} D_1 &= k_b E_{b1} I + k_s E_p I_p = \\ &= 0,09901 \cdot 0 \cdot 0,000447511 + 0,7 \cdot 206000 \cdot 0,000100139 = \\ &= 14.44004 \text{ MN m}^2 \end{aligned} \quad (3.15)$$

$$\begin{aligned} D_2 &= k_b E_{b1} I + l_o^2 / p^2 R_{pc} A_p = \\ &= 0,09901 \cdot 0 \cdot 0,000447511 + 6^2 / 3,14159^2 \cdot 215 \cdot 0,00797 = \\ &= 6.25028 \text{ MN m}^2 \end{aligned} \quad (3.16)$$

$$D = \min (D_1; D_2) = \min (14.44004; 6.25028) = 6.25028 \text{ MN m}^2.$$

Critical force:

$$N_{cr} = p^2 D / l_o^2 = \quad (3.17)$$

$$= 3.14159 \cdot 2 \cdot 6.25028 / 6 \cdot 2 = 1.7 \text{ MN}$$

Then

$N = 0.34 \text{ MN} < N_{cr} = 1.7 \text{ MN}$, which is 20% of the limit value, that is, the condition is fulfilled.

Determination of the calculated resistance of concrete:

Since

$$t_p/D_p = 0.008/0.325 = 0.02462.$$

Factor:

$$c = 25.$$

Limit bending moment:

$$M_{ult} = 2/3 \cdot 0,1545^3 \cdot 14,5 \cdot \sin(1,2621)^{3+1/3,1} \cdot 0,008 \cdot 0,16 \cdot \sin(1,2621) \cdot (215+215) = 0.196 \text{ MN m}$$

$$M = 0.051 \text{ MN m} < M_{ult} = 0.196 \text{ MN m} \text{ (26.1\% of the threshold) —}$$

the condition is met.

CHAPTER 4. TECHNOLOGY OF CONSTRUCTION

4.1. Field of application

The technology is advanced on the meter of final products – one building and provides for the installation of steel columns weighing 314.9, 316.2, 316.2, and 285.5 kg.

The technology also provides for the installation of steel support plates.

4.2. Characteristics of structures to be installed

The table shows the specification of structures for the setting up in which this technology is developed.

Table 4. 1

Installation element specification

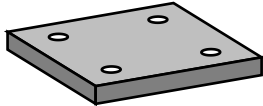
Item Name	Mark	Quantity, pcs.	Mass of elements, t	
			One	All
Support plate		16	0.6435	10.3
			Together	10,3
Column	K-1	8	0.3149	2.5192
	K-2	2	0.3162	0.6324
	K-3	2	0.3162	0.6324
	K-4	4	0.2855	1.142

4.3. The structure of the complex process and the scope of work

The structure of the complex process of installation of steel columns is determined by the constituent working processes.

Table 4. 2

Structure of the complex process of installation of steel columns

№	Name of process	Unit of measurement	Count record	Quantity
1	Unloading structures with a crane	100 t	$(0.315 \times 8 + 0.316 \times 2 + 0.316 \times 2 + 0.286 \times 4 + 10.3) / 100$	0.152
2	Installation of steel resistance plates	1 cooker	16	16
3	Grasp of steel support plates	1 cooker	16	16
4	Gravy concrete mixture under the slabs	1 m ³	0.028×16	0.448
5	Installation of columns	Piece.	16	16
		1 t	15.2	15.2
6	Installation and fastening of bolts	100 pcs.	$4 \times 16 / 100$	0.64

4.4. Selection of mounting cranes and cargo-lifting devices

4.4.1. Selection of cargo-lifting devices.

For the setting up of structures specified in the specification, taking into account characteristics, load-lifting devices are selected.

Table 4. 3

Cargo-lifting devices

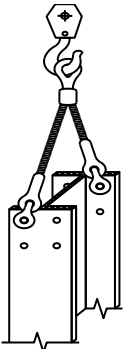
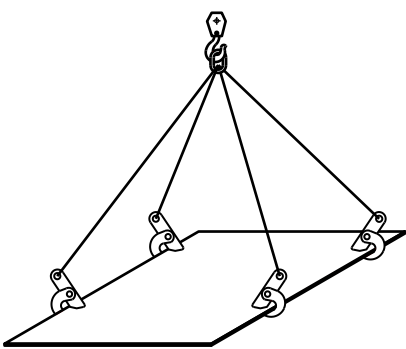
Appointment	Name	Schematic diagram	Carrying capacity, t	Own mass, t	Estimated height, m	Link to source
1	2	3	4	5	6	7
Slings steel columns	Universal sling	 <p>conditionally shown T-section</p>	4	0,08	1	□
Slings of supporting plates	Sling 4-branch		3	0,08	2,44	□

4.4.2. Specify mounting parameters.

To select crawler cranes, the necessary load characteristics were calculated according to the heaviest structure - column.

The required carrying capacity of the crawler crane is determined by the formula: Q_r

$$Q_r = m_e + m_{CT} = 0.316 + 0.08 = 0.396 \text{ т}, \quad (4.1)$$

where – m_e the mass of the element, т;

m_{CT} – strop mass (traverse), т;

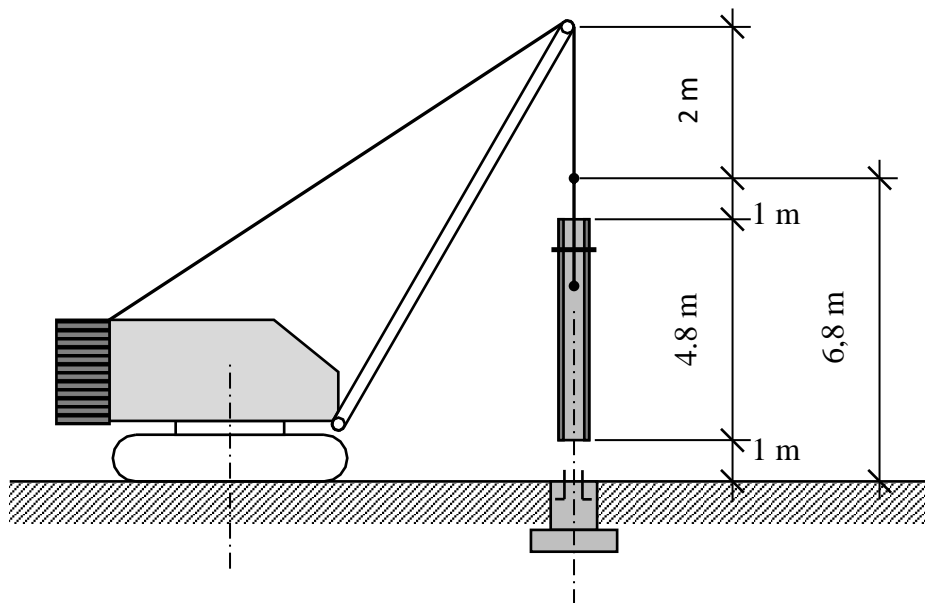

Fig. 3.1. Determine the required technical parameters of the boom crawler crane

The highest height of the hook lifting is determined by the formula:

$$H_r = h_0 + h_3 + h_e + h_{CT} = 0 + 1 + 4.8 + 1 = 6.8 \text{ m}, \quad (4.2)$$

where – the distance from the level of parking of the crane to the height of the support of the mounting element, m; h_0

h_3 – height reserve for the safety of installation; $h_3 = 1 \text{ m}$

h_{CT} – the height of slinging, m;

h_e – height or thickness of the element, m.

The radius of the crane hook L_r , based on the layout of the columns, is taken equal to 5.8 m.

The length of the boom is determined by the formula, m:

$$L_c = \frac{H_r + h_{\pi} + h_c}{\sin \alpha} = \frac{6.8 + 2 - 1.5}{0,8056} = 9.1 \text{ m}, \quad (4.3)$$

where – the distance from the axis of mounting the boom to the level of the crane parking; $h_c = 1,5 \div 2 \text{ m}$

$h_{\pi} = 2 \div 5 \text{ m}$ – the length of the cargo polyspast of the crane;

α – the optimal angle of inclination of the crane boom to the horizon.

For variant design, according to the results of the calculation, two variants of cranes were pre-selected.

Table 4. 4

Preliminary selection of cranes by calculated parameters

Name of cargo	Calculation parameters				Crane Options				
	Need carrying capacity Q_r, T	Required crane hook lifting height H_r, M	The required radius of the crane hook L_r, M	Boom length required L_c, M	Type, brand	Payload Q, T	Hook lifting height H, M	Crane hook radius L, M	Arrow length L_c, M
1	2	3	4	5	6	7	8	9	10
Column	0,396	6,8	5,8	9,1	MCG-25.01	15	13	5,8	14,4
					RDK-250	11,7	11	5,8	12,5

The graph of the cargo characteristics of the crane is given in the graphic part of the technology.

Of the two identical options (equal in carrying capacity), cranes are chosen economically at a minimum of the above costs.

After the corresponding calculations, a comparative one is made.

4.4.3. Choice of vehicles.

For the transportation of columns, depending on their weight and dimensions, the appropriate type and brand of vehicles are accepted, guided by the relevant reference literature. According to the passport parameters of vehicles, the number and method of laying elements are determined.

Table 4. 5

Vehicles

Name of the transported	Mass of construction. t	Dimensions of the structure. m $H \times b \times h$	Vehicle brand	Carrying capacity q . t	Cargo transported		Factor K_T
					N , pcs.	Q , t	
K-1;	0.3149;	4.8×0.28×0.28;	Semi-trailer	12	8;	2.519;	0.2;
K-2;	0.3162;	10.105×0.28×0.28;	UPR-1212M		2;	0.632;	0.05;
K-3;	0.3162;	11.2×0.28×0.28;	and tractor		2;	0.632;	0.05;
K-4	0.2855	6.7×0.28×0.28	MAZ-6422		4	1.142	0.09

The choice of vehicles was approved out taking into account the ratio of usage of the vehicle K_T :

$$K_T = \frac{Q}{q} \leq 1, \quad (4.4)$$

where Q – the cargo being transported, t;

q – load capacity of the vehicle, t.

4.5. Organization and technology of work

When fitting steel structures should be guided by the requirements. All labor should be approved out following the requirements of DBN A.3.2-2-2009

"System of labor safety standards. Industrial safety in construction. the main provisions."

Resistance slabs are installed on the foundation with three connection bolts screwed into the nuts welded to the stove. After calibration, the plates are secured from moving upwards with spacer tubes, which are worn on anchor bolts. The tubes with the lower end rest on the strips with holes that are welded to the bottom of the resistance plate, and their upper ends are clamped with nuts of anchor bolts.

Perform casting of resistance plates, and after the anguishing of the solution is removed from the anchor bolts of the spacer tube and grasp the strips to the anchor bolts by welding.

Before slinging, the columns are prepared with mounted ladders with stands. Setting up of columns includes the next operations: slinging; transfer from a horizontal position to vertical; supply to the foundation in an elevated position; lowering on the foundation.

Postponement is performed after fixing the column with anchor bolts, the nuts of which are tightened to the design value. In the course of the slightest rigidity, the clues are mounted, which are detached after the installation of elms - spacers and crane beams. The lurch is fixed to the column on the ground before lifting them. The lower ends of the seedlings are attached to the foundations, for which earlier it is necessary to provide for the laying of the necessary parts in them.

4.6. Requirements for the quality of work

When accepting works, it is needed to be guided by the supplies for the quality of work performed.

Table 4. 6

Requirements for the quality of acceptance of works

Setting	Limit deviations, mm	Control (methods, volume, type of registration)
1. Deviation of the marks of the supporting surfaces of the column and supports from the design	5	Measuring, each column, and supporting, the geodetic executive scheme
2. The difference in the marks of the supporting surfaces of neighboring columns and supports in a row and the span	3	Likewise
3. Displacement of the axes of columns and supports relative to the axes of the breakdown in the supporting section	5	Likewise
4. Deviation of columns axes from the vertical at the upper section at the length of the columns, mm: more than 4000 to 8000 "8000" 16 000 "16 000" 25 000	10 12 15	Likewise
5. Arrow deflection (curvature) of the column, support, and ligaments on the columns	0.0013 distances between anchor points, but not more than 15	Measuring, each element, work history
6. The one-sided gap between milled surfaces in the joints of columns	in this case, the contact area should be at least 65% cross-sectional area	Likewise

4.7. Calculation of labor costs and machine time

The calculation of labor costs, machine time, and wages are formed in the form of a table.

Table 4. 7

Calculation of labor costs, machine time, and wages

№	Name of process	Unit of measurement	Amount of work	Norm of time		Labor costs	
				man.-h.	mash.-h.	man.-h.	mash.-h.
1	Unloading structures with a crane	100 t	0.152	22	11	3.34	1.67
2	Installation of steel resistance plates	1 cooker	16	5.8	1.9	92.8	30.4
3	Grasp of steel support plates	1 cooker	16	1.2	-	19.2	-
4	Gravy concrete mixture under the slabs	1 m ³	0.448	2.2	-	0.99	-
5	Installation of columns	Piece.	16	3	0.6	48	9.6
		1 t	15.2	0.54	0.11	8.21	1.67
6	Installation and fastening of bolts	100 pcs.	0.64	11.5	-	7.36	-

4.8. Schedule of work

For drawing up a schedule of work used data calculation of labor costs and machine time. The schedule is built taking into account the mutual coordination of processes and technical and organizational features.

Table 4. 8

Schedule of work on the installation of columns

№	Name of process	Unit of measurement	Amount of work	Labor costs		Duration of the process
				man.-sh.	mash.-sh.	
1	Unloading structures with a crane	100 t	0.152	0.42	0.21	1
2	Installation of steel resistance plates	1 cooker	16	11.6	3.8	5
3	Grasp of steel support plates	1 cooker	16	2.4	-	2
4	Gravy concrete mixture for supporting slabs	1 m ³	0.448	0.12	-	1
5	Installation of columns	Piece.	16	6	1.2	2
		1 t	15.2	1.03	0.21	
6	Installation and fastening of bolts	100 pcs.	0.64	0.92	-	1

4.9. The need for material and technical resources

All calculations of material and technical resources are made for the entire amount of work.

The need for tools, tools, and devices is determined based on the analysis of labor processes and operations in this technological map, using standards, typical technological maps, and reference literature.

Table 4. 9

Statement of the need for materials and semi-finished products necessary for the implementation of the work

Name of material, semi-finished product	Unit of measurement	The volume of work in normative units	Accepted rate of consumption of materials	The need for materials
Electrodes, ø4 mm, brand E46	t	10.3	0.0004	0.0041
Electrodes, ø2 mm, brand E42	t	15.2	0.0004	0.0061
Channel N40 made of ordinary carbon steel	t	25.5	0.00194	0.0495
Other materials, individual structures and fastening parts	t	15.2	0.00031	0.0047

4.10. Safety and labor protection

Under construction and works it is essential to be guided by the requirements of DBN A.3.2-2-2009 "System of labor safety standards. Industrial safety in construction" and "Instruction on labor protection during the installation of metal and reinforced concrete structures".

On the construction site by order to appoint in each shift from among foremen or heads of plots:

- workers responsible for the safe operation of removable cargo-lifting devices and containers;
- the worker responsible for the safe operation of the crane;
- slingers.

Thrilling machines, removable load-lifting devices, and containers that have not undergone technical review are not allowed to work.

All work is approved under the management of somebody responsible for the safe conduct of work.

Workers working at altitude are provided with proven and tested safety belts with safety carabines attached to a reliable design indicated by the master or foreman. Belts must be registered and tested. Workers of all specialties must be provided with protective helmets and overalls.

Workers must have a certificate for the right to produce a particular type of work and must be instructed on safety following the requirements.

Do not allow unmarked or defective removable load-lifting devices.

It is not allowed to sling cargo in a shaky position, correct the position of elements of slinging equipment on the raised cargo, or pull the cargo at an oblique position of cargo ropes.

When unloading with a crane of long-sized structures, use flexible grinding to eliminate the reversal of structures raised by the crane.

The unsafe area of the crane is enclosed with a defensive fence with clearly visible signs enlightening them in the dark. On the edge of the hazard, sector mount signs warning about the process of the crane. Safety signs mounted on the carriageway of a temporary road should be hung on a stretched cable.

It is forbidden to perform installation work at a height in open places at wind speeds of 15 m / s or more, with ice, thunderstorm, or fog.

To inform the painting with the data of the project crane operators, slingers, and persons responsible for the safe operation of cranes.

When slinging structures with sharp ribs by strapping, it is essential to mount gaskets between the edges of the elements and the rope that protect the rope from grinding. Gaskets must be devoted to the load or as inventory permanently fixed on the sling.

It is prohibited to warehouse materials and products on bulk non-compacted soils. Materials (structures) should be located after the requirements on aligned sites. Storage sites should be endangered by surface water.

For the transition of installers from one structure to another, stairs, transitional bridges and fencing canopies should be used.

In the process of installation of structures, installers must be on previously installed and securely fixed structures or means of strengthening.

It is forbidden to stay on the elements of structures and equipment during their lifting and movement.

Before starting installation work, it is essential to establish the procedure for exchanging signals between the driver and the person directing the installation.

The elements of structures or equipment mounted in the design location should be fixed so that their stability and geometric immaculateness are guaranteed.

Grinding should be located outside the dimensions of traffic and construction machinery. Thrusting should not touch the sharp corners of other structures. Inflection of incest in places of their adhesion to elements of other structures is permitted only after inspection of the strength and stability of these elements under the effect of efforts from incest.

Lifting structures to achieve in two doses: first to a height of 20-30 cm, then after checking the reliability of slinging to do the supplementary lifting.

When moving structures or equipment, the distance between them and the protruding parts of the mounted equipment or other structures should be horizontally at least 1 m, and vertically - at least 0.5 m.

During work breaks, it is not allowed to leave the raised elements of structures and equipment in a suspended position.

4.11. Technical and economic indicators

1. Normative labor costs of workers: 22.49 man.-sh;
2. Normative labor costs of machine time: 5,42 mash.-sh;
3. Duration of work according to the schedule: 8 sh;
4. Planned production of one worker per shift calculated by the formula:

$$B = \frac{V}{\sum m_p} = \frac{15,226}{22,49} = 0,68 \frac{\tau}{\text{люд.}-\text{зм.}}$$

where – the volume of final products, that is; V

$\sum m_p$ – labor costs for the amount of work in this region, man.-sh

CONCLUSIONS

In this work was designed Industrial building in Gostomel city of Kyiv region.

The first part of this thesis describes the analytical review.

The second part of this thesis describes the Architectural solution of the Industrial building. The building was designed in Gostomel city of Kyiv region.

The land plot for the construction of a repair and mechanical workshop is located at a sanitary distance from the residential buildings in the Gostomel city of Kyiv region.

The master plan envisages the rational placement of the repair and mechanical workshop on the part of the metering and parting unit free from technological equipment.

Surface water drainage is designed of open type and is carried out by planned planes and trays.

The construction site has a rectangular shape with a branch and is located in the area of the field.

The plot has an area of 11 hectares and a uniform slope from east to west.

The project of vertical planning of the location is advanced on the principle of thoroughgoing preservation of the prevailing relief taking into account hydrogeological landscapes, architectural and planning conclusions of the projected building, and the necessities of regulatory documents.

The position of the building on the site, taking into account its amount of stories, does not violate regulatory necessities for the insolation of neighboring buildings.

To ensure sanitary and hygienic necessities, as well as the normal movement of vehicles and walkers, the fixing of gravel, gravel, and bitumen

pavement on driveways and sites. The design of the pavement is created on the intensity of traffic.

The plan of the organization of a relief of a site under construction is advanced taking into account existing marks of relief of adjoining grounds. Drainage of the stream and melt water from the location is supported superficially, towards the natural fall of the terrain.

The principal plan is made taking into account the standing buildings, traffic conditions, and walkers.

Planning marks are accepted taking into account the opportunity of suitable and safe passes of transport, and ordinary slopes.

The maximum preservation of existing landscaping is expected. Travel to the repair shop is done with asphalt pavement.

Throughout the rest of the field, the driveways are made of gravel, and pedestrian paths are gravel.

In the exterior decoration, modern finishing materials are used, and modern metal-plastic windows with double-glazed windows are installed.

The architectural planning and three-dimensional decision of the repair and mechanical workshop were determined founded on the local situation, the size of the land, and the directing distances to the present buildings.

For the ease of staff in front of the key entrance to the building is a place for temporary parking. For quality recreation during the break next to the building is a recreation area with minor architectural arrangements.

The structure of the building is designed as a frame, with one span of columns and a roof of steel trusses.

Facade elements are numerous with the application of up-to-date design attainments.

Rigidity is guaranteed by the combined behavior of tubular steel-concrete columns, steel trusses, and horizontal and vertical links.

The building is considered to use individual steel and tubular manufactured structures of columns and trusses.

The constructive is solved by one span of 18 m from a framework with two rows of tubular steel-concrete columns with support on them of steel trusses of a covering located with a step of 6 m.

The building of the repair and mechanical workshop is considered as a one-story frame one-span with walls of hinged three-layer panels.

The key goal of the foundations is the allocation of loads from the building to the foundation. Taking into account the characteristics of the soil of the construction site grounded on technical and economic analysis of the foundations adopted a shallow foundation monolithic glass type with manufactured reinforced concrete foundation beams under the outer walls. The depth of the foundations is 1.5 m.

Partitions between individual sections are considered with a thickness of 100 mm from a steel frame lined with steel sheets.

External walls from the conditions of heat engineering are accepted from three-layer sandwich panels 300 mm thick.

The roof is premeditated from three-layer sandwich panels with a thickness of 0.300 m, which are laid on the scaffolding of steel girders from the channel №8, laid on the upper belt of trusses with a step of 1.500 m.

The roof is considered from steel trapezoidal trusses with a height of 2.400 m from two equal-shelf corners of individual manufacture. Roof trusses are created on individually made tubular steel-concrete columns. The choice of the type of columns is made grounded on technical and economic analysis of different sorts of columns.

Exterior finishing of the building is performed following the passport of external finishing.

The inner ornamentation of the rooms is achieved giving information about finishing works.

Door leaves, heaters, and tubes are painted with enamel paint twice.

Filling of window and door openings. The natural illumination of the building is provided by window openings.

Metal elements are to be treated with black varnish 2 times.

The project envisages the installation of metal-plastic window blocks with double glazing. The closure of metal-plastic window blocks is approved using self-tapping screws before scaffolding on steel-concrete columns. The seams between the window blocks and the walls are filled with spume.

Door leaves are fixed on two hinges. The building has steel and plastic-wooden doors considered. All doors are made deaf. Door frames are devoted with self-tapping screws to the scaffolding on the wall frame. The seams between the door frames and the outer walls are filled with spume.

Due to the non-aggressiveness of the air environment, the protection of strengthened concrete structures is not provided.

Protection of building structures from corrosion.

Protection of interior and outside metal structures is provided by two times oil paintings.

The walls at the bottom of the window openings are covered with galvanized steel drains. Defense of structures from the outside effect of the air is reduced to protection from precipitation.

Guard of entrenched parts as anchors and other metal elements unseen in the structures under construction is achieved by covering with a cement-polymer layer.

Heating networks – the source of supply - heat generator in the existing operator building. The heat carrier is water with parameters 95° – 70° . Heat network from steel pipes.

Ventilation of premises is accepted supply and exhaust mechanical and natural.

The project adopts underground duct laying of thermal networks in impassable strengthened concrete trays unconnectedly for heating and hot water supply.

The source of the water supply of the repair shop is the current water supply system with a diameter of 50 mm.

The internal sewerage network is made of cast iron sewer pipes. External sewerage networks are laid from ceramic sewer tubes with a diameter of 150 mm to biological treatment plants.

Outside networks are considered from cast iron pressure tubes. Wells on the network are made of produced strengthened concrete elements.

REFERENCES