

**МІНІСТЕРСТВО ОСВІТИ ТА НАУКИ УКРАЇНИ
НАЦІОНАЛЬНИЙ АВІАЦІЙНИЙ УНІВЕРСИТЕТ
Кафедра конструкції літальних апаратів**

ДОПУСТИТИ ДО ЗАХИСТУ

Завідувач кафедри

д.т.н., проф.

_____ Сергій ІГНАТОВИЧ

«_____» _____ 2022 рік

**ДИПЛОМНА РОБОТА
ЗДОБУВАЧА ОСВІТНЬОГО СТУПЕНЯ "БАКАЛАВР"
ЗІ СПЕЦІАЛЬНОСТІ
«АВІАЦІЙНА ТА РАКЕТНО-КОСМІЧНА ТЕХНІКА»**

**Тема: «Аванпроект пасажирського дальньомагістрального
літака місткістю 186 пасажирів»**

Виконав: _____ *Тань Лун* **ТАНЬ Лун**

Керівник: _____ **Ю.В.Власенко**

Нормоконтролер: канд.техн.наук, доцент _____ **Сергій ХИЖНЯК**

Київ 2022

**MINISTRY OF EDUCATION AND SCIENCE OF UKRAINE
NATIONAL AVIATION UNIVERSITY
Department of Aircraft Design**

PERMISSION TO DEFEND

Head of the department

Dr.Sc., Professor

_____ Sergiy IGNATOVYCH

«__» _____ 2022

**BACHALOR DEGREE THESIS
ON SPECIALTY
"AVIATION AND AEROSPACE TECHNOLOGIES "**

Topic: «Preliminary design of a long-range aircraft with 186 passenger capacity»

Prepared by:

Tan Long

Tan Long

Supervisor:

Y.V.Vlasenko

Standard controller: PhD, associate professor _____

Sergiy KHIZNYAK

Kyiv 2022

NATIONAL AVIATION UNIVERSITY

Aerospace Faculty

Department of Aircraft Design

Academic Degree «Bachelor»

Specialty: 134 "Aviation and Aerospace Technologies"

APPROVED BY

Head of the Department

Dr.Sc., Professor

_____ Sergiy IGNATOVYCH

«___» _____ 2022

TASK

for the bachelor degree thesis

TAN LONG

1. Topic: « Preliminary design of a long-range passenger aircraft with 186 passenger capacity » confirmed by Rector's order № 489/CT from 10.05.2022.
2. Thesis term: from 23.05.2022 to 19.06.2022.
3. Initial data: cruise speed $V_{cr}=850$ kmph, flight range $L=7200$ km, operating altitude $H_{op}=11$ km, 186 passengers.
4. Content (list of topics to be developed): choice and substantiations of the airplane scheme, choice of initial data; engine selection, aircraft layout, center of gravity position calculation, design of the passenger seat.
5. Required material: general view of the airplane (A1×1); layout of the airplane (A2×1); passenger seat assembly drawing (A1×1).

Graphical materials are performed in AutoCAD, CATIA.

6. Thesis schedule:

Task	Time limits	Done
Task receiving, processing of statistical data	23.05.2022–28.05.2022	<i>Tan Long</i>
Aircraft geometry calculation	28.05.2022–31.05.2022	<i>Tan Long</i>
Aircraft layout	31.05.2022–03.06.2022	<i>Tan Long</i>
Aircraft centering	03.06.2022–05.06.2022	<i>Tan Long</i>
Graphical design of the parts	05.06.2022–12.06.2022	<i>Tan Long</i>
Completion of the explanation note	12.06.2022–14.06.2022	<i>Tan Long</i>
Defense of diploma work	14.06.2022–19.06.2022	<i>Tan Long</i>

7. Date: 23.05.2022

Supervisor

Y.V.Vlasenko

Student

Tan Long

Tan Long

НАЦІОНАЛЬНИЙ АВІАЦІЙНИЙ УНІВЕРСИТЕТ

Аерокосмічний факультет

Кафедра конструкції літальних апаратів

Освітній ступінь «Бакалавр»

Спеціальність 134 «Авіаційна та ракетно-космічна техніка»

Освітньо-професійна програма «Обладнання повітряних суден»

ЗАТВЕРДЖУЮ

Завідувач кафедри, д.т.н, проф.

_____ Сергій ІГНАТОВИЧ

«_____» _____ 2022 р.

ЗАВДАННЯ

на виконання дипломної роботи студента

ТАНЬ ЛУН

1. Тема роботи: «Аванпроект пасажирського дальньомагістрального літака місткістю 186 пасажирів», затверджена наказом ректора № 489/ст від 10 травня 2022 року.
2. Термін виконання роботи: з 23 травня 2022 р. по 19 червня 2022 р.
3. Вихідні дані до роботи: максимальна кількість пасажирів 186, дальність польоту з максимальним комерційним навантаженням 7200 км, крейсерська швидкість польоту 850 км/год, висота польоту 11 км.
4. Зміст пояснювальної записки: вибір параметрів та обґрунтування схеми проектованого літака, вибір двигунів, розрахунок геометрії та центрування літака, дизайн сидіння пасажирів.
5. Перелік обов'язкового графічного матеріалу: загальний вигляд літака (A1×1), компоновальне креслення фюзеляжу (A2×1), малювання збирання сидів пасажирів (A1×1).

6. Календарний план-графік:

Завдання	Термін виконання	Відмітка про виконання
Вибір вихідних даних, аналіз льотно-технічних характеристик літаків-прототипів	23.05.2022–28.05.2022	Плань Лун
Вибір та розрахунок параметрів проєктованого літака	28.05.2022–31.05.2022	Плань Лун
Виконання компонування літака	31.05.2022–03.06.2022	Плань Лун
Розрахунок центрування літака	03.06.2022–05.06.2022	Плань Лун
Виконання креслень літака	05.06.2022–12.06.2022	Плань Лун
Оформлення пояснювальної записки та графічної частини роботи	12.06.2022–14.06.2022	Плань Лун
Захист дипломної роботи	14.06.2022–19.06.2022	Плань Лун

7. Дата видачі завдання: 23.05.2022 рік

Керівник дипломної роботи

_____ Ю.В.Власенко

Завдання прийняв до виконання

Плань Лун ТАНЬ Лун

Content

INTRODUCTION.....	9
1. AIRCRAFT PRELIMINARY DESIGN	12
1.1 Analysis of prototypes and short description of designing aircraft.....	12
1.1.1 Choice of the projected data.....	12
1.1.2 Brief description of the main parts of the aircraft.....	13
1.2 Geometry calculations for the main parts of the aircraft.....	22
1.2.1. Wing geometry calculation	22
1.2.2 Fuselage layout.....	25
1.2.3 Galleys and buffets.....	27
1.2.4 Lavatories	28
1.2.5 Calculation of basic parameters of tail unit	28
1.2.6 Landing gear design	31
1.2.7 Choice and description of power plant	33
1.3 Center of gravity calculation.....	34
1.3.1 Trim sheet of equipped wing	34
1.3.2 Trim-sheet of the equipped fuselage.....	36
1.3.3 Calculation of center of gravity positioning variants.....	37
Conclusions to the main part.....	39
2. PASSENGER SEAT DESIGN	40
2.1 Introduction	40
2.2 Description of the main part of seat	41
2.3 Calculation of seat.....	43
2.4 Strength analysis	50
Conclusions to the special part.....	56
References:	57
Appendix A	58

<i>Department of Aircraft Design</i>			<i>NAU 22 17T 00 00 00 61 EN</i>				
<i>Performed by</i>	<i>Tan Long</i>	<i>Tan Long</i>	<i>Content</i>		<i>Letter</i>	<i>Sheet</i>	<i>Sheets</i>
<i>Supervisor</i>	<i>Vlasenko Y.V.</i>					<i>8</i>	<i>59</i>
<i>Adviser</i>					<i>402AF 134</i>		
<i>Stand. contr.</i>	<i>Khizhnyak S.V.</i>						
<i>Head of dep.</i>	<i>Ignatovych S.R.</i>						

ABSTRACT

Explanatory note to the diploma work “Preliminary design of the long-range passenger aircraft with 186 passenger capacity” contain:

Pages, figures, tables, references and 4 drawings

Object of the design is a long-range aircraft with 186 passenger capacity.

Subject of the design a new design of passenger seats in the economy class and perform it's strength analysis.

Aim of the diploma work is the preliminary design of the long-range passenger aircraft based on the prototypes with the layout of the passenger cabin, conceptual design of the passenger seats.

Research and development methods are analyze prototypes, select the parameters that best suit the design aircraft, estimate geometric features based on statistical recommendations, calculate the center of gravity of the designed aircraft, 3D modeling of passenger seats, stress-strain analysis of the basic structure of the seat.

Novelty of the results is defined as the design of a long-range aircraft with a capacity of 186 passengers, the calculation and drawing of the aircraft layout, and the conceptual design of passenger seats.

Practical value

The results of the work can be implemented both into the practice of aviation design bureaus and into the educational process related to the fatigue and fracture, fracture mechanics, aircraft design, aircraft equipment, etc.

AIRCRAFT, PRELIMINARY DESIGN, CABIN LAYOUT, CENTER OF GRAVITY POSITION, PASSENGER SEAT, STRENGTH ANALYSIS,

INTRODUCTION

My task in this diploma work is to create an aircraft intended for the carriage of 186 passengers and baggage on middle distance routes.

Due to the improvement of modern living standards, people's requirements for travel transportation are also getting higher and higher. The comfort, safety, speed and convenience of the way of travel are the basis for choice, whether the distance is short or long, the aircraft is an important travel transportation. It is also a transport activity, which is an integral sector of transport, which, together with railway, road, waterway and pipeline transport, constitutes the national transport system of transport. Although air transport is less than other modes of transport in terms of transportation volume, due to the ability and high efficiency of fast and long-distance transport, air transport has continuously improved its ranking in terms of total output value, and it has played an irreplaceable and increasing role in international exchanges in the wave of economic globalization.

In order to meet the travel needs of 186 people, a single aisle, narrow-body medium-range civil air transport aircraft needed to be designed. As oil prices rise slowly every year, the cost of fuel consumption leads to a gradual increase in air freight costs. In the past, the fuel consumption of civil airliners was very high, so it was particularly necessary to develop new passenger aircraft with low fuel consumption. In the mid-1970s, Boeing developed a new 200-seat model to replace the Boeing 727 and Boeing 707, initially named the 7N7 (N refers to narrow body). In 1983, the Boeing 757 was put into service, and in 2018, the Boeing 757 was officially retired in China. I studied the various performance and data of the Boeing 757 and, after comparing it with other models on the market, decided that its relatively new design could be carried out in the next airliner design with the Boeing 757 as a prototype.

In order to ensure that the aircraft is designed to be acceptable to airlines and

<i>Department of Aircraft Design</i>			<i>NAU 22 17T 00 00 00 61 EN</i>					
<i>Performed by</i>	<i>Tan Long</i>	<i>Tan Long</i>	<i>Introduction</i>		<i>Letter</i>	<i>Sheet</i>	<i>Sheets</i>	
<i>Supervisor</i>	<i>Vlasenko Y.V.</i>					<i>10</i>	<i>59</i>	
<i>Adviser</i>					<i>402AF 134</i>			
<i>Stand. contr.</i>	<i>Khizhnyak S.V.</i>							
<i>Head of dep.</i>	<i>Ignatovych S.R.</i>							

passengers, I will consider all aspects of the aircraft's performance.

1. Flight performance of the aircraft in the medium distance;
2. Fuel consumption in flight;
3. Aircraft safety;
4. The aesthetics and comfort of the aircraft.

For aircraft design, I should consider the range, the number of passengers, the mass of all structures and payloads, and the aerodynamic numbers. Then some necessary calculations are made to determine the parameters of all the structures. After all this, I should make sure that anything is within the limits to make sure the aircraft can be designed.

1. AIRCRAFT PRELIMINARY DESIGN

1.1 Analysis of prototypes and short description of designing aircraft

1.1.1 Choice of the projected data

The main task of aircraft design is to ensure the optimization of the overall data of the aircraft. The selection of aircraft optimal parameters should be based on a variety of considerations, such as the overall weight of the aircraft, the number of passengers, flight range, complex structures, aerometric dynamics and so on. Statistical methods, combined with the parameters of prototypes, can be very good choice to design the best data of the aircraft. Prototypes of this aircraft, taking for the designing aircraft were in class 180-250 passengers. Such as Boeing 757-200, Boeing 757-200F and Boeing 757-300 will be compared with designed aircraft in this project. Statistic data of these prototypes are presented in table 1.1[1].

Table 1.1 – Operational-technical data of prototypes

PARAMETER	PLANES		
prototype	B 757-200	B757-200F	B757-300
The purpose of airplane	Passenger	Cargo	Passenger
Crew/flight attend. persons	2/5	2/2	2/5
Maximum take-off weight, m tow, kg	115650	116650	122470
Max pay-load, m κ. max, kg	25920	38290	30910
Passenger's seat	200	-	243
The height of the flight H_f m	14000	14000	14000
Range $m_{k.max}$, km	7275	5834	6421
Take off distance L, m	18900	18900	18900
Sweepback on 1/4 chord, 0	30	30	30

*Department of
Aircraft Design*

NAU 22 17T 00 00 00 61 EN

Performed by	Tan Long	Tan Long		<i>Preliminary design</i>	Letter	Sheet	Sheets
Supervisor	Vlasenko Y.V.					12	59
Adviser					<i>402AF 134</i>		
Stand. contr.	Khizhnyak S.V.						
Head of dep.	Ignatovych S.R.						

1	2	3	4
Number and type of engines	2, RB211- 535E4B	2, RB211- 535E4B	2, RB211- 535E4B
The form of the cross-section fuselage	circular	circular	circular
Extension of the fuselage	40.32	40.32	40.32
Extending the nose and tail unit part	5/10	5/10	5/10

The basic data of the design aircraft are selected by the data of prototypes in Table 1.1, and other parameters are calculated according to the aerodynamic formula. Ensuring the correctness of the data, will improve the practical and economic benefits of the aircraft

1.1.2 Brief description of the main parts of the aircraft

The aircraft is an all-metal semi-hard shell broken safety structure, based on the Fuselage of the Boeing 727, retaining the ovoid-shaped fuselage cross-sectional surface, which consists of two arcs of different diameters. Redesign the head with single-sided cockpit windscreen to reduce drag and noise. There are 5 main components of an aircraft: Wings, Fuselage, Empennage, Power Plant and Landing Gear [2]. The lengthening of the fuselage is the constant part of the diameter of the mid-section, thus adding a great deal of resistance. The Boeing 757 wings feature a single wing under the cantilever, a 25-degree angle behind a 1/4-string line, and a broken safety structure with aluminum alloy double beams. Wing girders cross the fuselage.

The full-wing front edge seam wing is divided into 5 sections on each side, full-speed aileron, each wing rear edge flap front wing surface has 5 flight spoilers and a ground spoiler. Ground spoilers can be used as deceleration plates. Compared with earlier aircraft, the wing rear flange is slightly smaller and the center part is thicker and has a longer wingspan. Its lower surface is smoother and its leading edge is sharper. Flat tail is a normal light alloy anti-twisting box structure. The tail is a three-

beam, two-chamber anti-twisting box structure.

Fuselage

The fuselage carries most of the payload and is the main body of all components. It must be able to resist bending moment caused by weight and tail lift, torsional load caused by rudder and pressure difference in engine room (as shown in Figure 2.1). Fuselage siding is generally hyperbolic, which can be divided into positive curvature siding and negative curvature siding after the mouth cover is divided. Under the overall load, the upper siding is mainly in tension, while the lower siding is mainly in compression. The structural strength and stiffness of the fuselage must be large enough to withstand these loads, and the structural weight must be kept to a minimum.

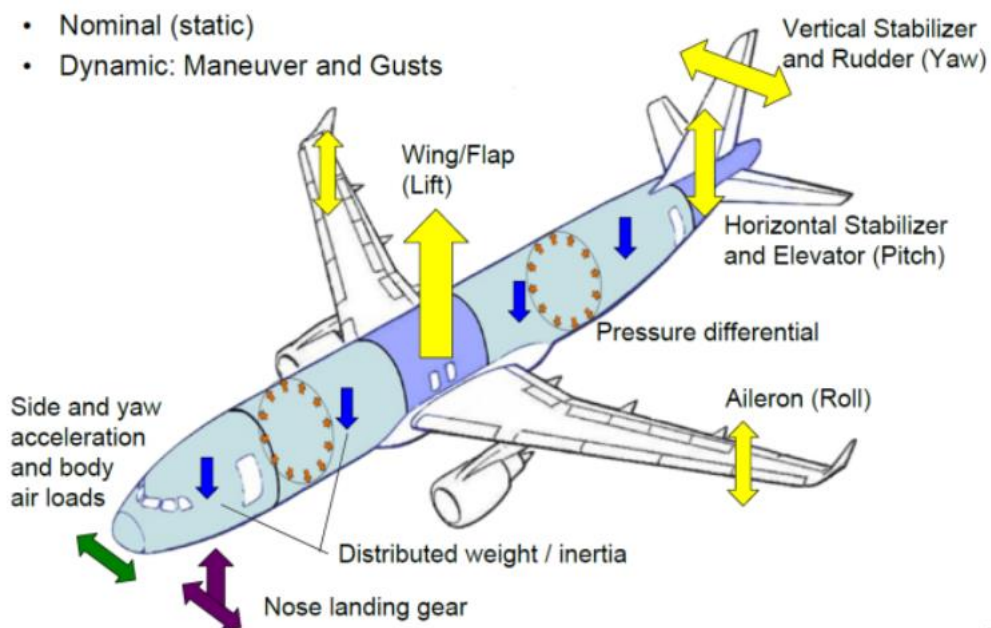

Figure 1.1 - The main force on the fuselage

The frame maintains the shape of the fuselage cross-section and prevents it from buckling under bending loads. Under torsion and bending loads, the longitudinal beam greatly increases the stiffness of the skin and minimizes the weight increase. The frame and longitudinal beam form the basic frame of the fuselage. The pressure bulkheads block the pressure chambers at both ends of the fuselage to carry the load

imposed by pressurization. They can take the form of flat discs or curved bowls.

The fuselage of this aircraft takes the fuselage structure of Boeing 727 as the basic condition, and retains the oval fuselage section shape. On this basis, other designs are added, such as changing the windshield of the cockpit in the head design to reduce the resistance and noise of the aircraft. In the design process, the central fuselage profile height needs to meet the requirements of the passenger and cargo cabin layout height the fuselage length is shortened by several meters on the basis of the prototype aircraft. On the premise that it is suitable for arranging seats, the weight of the aircraft is reduced and the resistance suffered by the aircraft during flight is reduced.

Wing

The wing is an important part of the aircraft. It is installed on the fuselage and provides lift. Together with the tail wing, it provides the stability of the fuselage. The success of wing design is the key to the success of civil transport aircraft. The main structure of the wing is: skin, wing rib, longitudinal beam and wing beam. During flight, it will generate load, which is transmitted to the wing bones and beams through the skin, and then to the fuselage. There are many lift control devices on the wing, namely ailerons, flaps, spoilers and leading edge slats. They are controlled by the aircraft's flight system, which changes the lift and speed of the aircraft. There are two engines under the wing, and ram air will enter the engine to generate thrust. Fuel efficiency can be improved by modifying / changing the design of objects. Therefore, we should consider the wing load and strengthen the wing structure, such as wing beam. The leading edge of the wing is equipped with air heating and electric heating anti icing devices. The main load acts on a structure called the wing box, and other structures transfer the load to the wing box.

There is a large landing gear under the aircraft to reduce the impact of the ground on the aircraft, which will produce a more stable state for the aircraft during take-off and landing. Aircraft landing gear is the load-bearing device of aircraft during

takeoff and landing, taxiing and ground parking. It is an important guarantee for the safety of aircraft takeoff and landing. Landing with the landing gear is less dangerous to passengers and aircraft. The wings receive impact energy to protect the cabin. When landing on the water, it will provide additional buoyancy for the aircraft.

The wing design can further reduce the aspect ratio by increasing the sweep angle, so as to reduce the shock drag and achieve the purpose of increasing the lift drag ratio. Figure 1.2 shows the wing of the design aircraft:

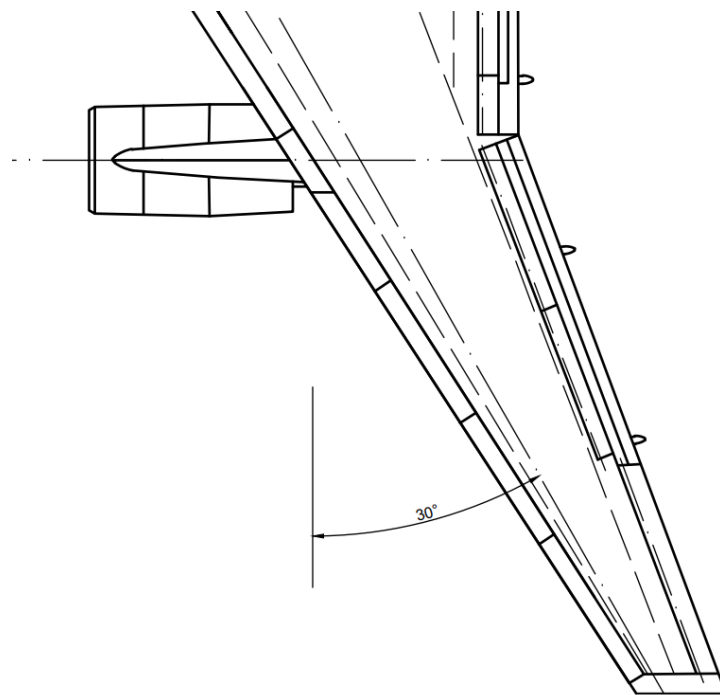

Figure 1.2 – design of swept wing

However, the swept wing structure also has several disadvantages:

Large tearing speeds and landings as well as longer runways;

It has smaller aerodynamic mass than the straight wing, greater aircraft drag, and shorter range and flight duration;

The air flow tends to flow out of the tail of the wing;

The maximum lift coefficient is the lowest compared with others;

The external lateral stability is poor, causing the aircraft to swing;

Due to wing end stall, lateral controllability is reduced at high angles of attack, with reverse roll response.

Lateral stability decreases with $M > M_{max}$ (Mach number), which requires greater tearing and landing speeds and longer operating distances. Aerodynamic mass is smaller than direct mass, aircraft has greater resistance, shorter range and longer flight distance.

Tail unit

The tail of an aircraft plays an important role in the structure and function of the aircraft. Each part of the aircraft is affected by four forces: lift, drag, weight and thrust. Lift and drag determine the aerodynamic efficiency of the object. Together with the wings, they control the flight state of the aircraft and provide the flight stability of the aircraft.

The tail of an aircraft is mainly composed of a vertical tail and a horizontal tail. The horizontal tail, like the wing, will generate upward lift to maintain the longitudinal stability of the fuselage. The flat tail is arranged at the tail of the aircraft and is basically in a horizontal position. The front half of the wing is usually fixed and is called the horizontal stabilizer. The rear half is hinged behind the stabilizer surface and can be deflected up and down. It is called elevator. The rear edge of the elevator is also equipped with an adjusting plate. During flight, the elevator can deflect up and down at different angles, change the drag and lift of the tail wings on both sides, and make the aircraft tilt in the air.

The vertical tail keeps the flight stability and maneuverability of the aircraft, similar to the flat tail. The vertical tail is only arranged at the upper part of the aircraft axis. Because the head of the aircraft is raised during takeoff and landing, the tail will be very close to the ground (as shown in Figure 1.3).



Figure 1.3 - aircraft during take-off

Like the horizontal tail, the front half of the vertical tail is usually fixed, which is called the vertical stabilizer, and the rear half is hinged at the rear of the stabilizer surface, which can manipulate the deflection, which is called the rudder. The tail is used to keep the turning in a non-sideslip state, keep the fuselage head aligned with the runway when the crosswind lands, and balance the asymmetric yaw moment in flight. The damper can be installed in the rudder control system to prevent yaw swing in high-altitude and high-speed flight.

Crew cabin

The crew cabin is the cockpit where the pilot controls the aircraft. It is located in the front of the aircraft. It is closed and separated by the doors between the passenger cockpits. Various types of flight instruments and aircraft control systems are installed in the cockpit of the aircraft. Most system related controls (e.g. electrical, fuel, hydraulic, and pressurization) are located on the top of the ceiling.

The radio equipment is placed on the panel between the pilot seats. There are also certain requirements for the basic performance of the radio man-machine interface in the cabin, such as screen definition and size. The autopilot with automatic flight control is usually placed on the sun visor on the windshield directly below the main instrument panel.

The core concept of cockpit design is the design eye position or "DEP" visible from all angles.

Electronic flight instruments used in the cabin include: mode control panel, main flight display, navigation display, engine indication and crew early warning system

/ electronic central aircraft monitoring, flight management system and various standby instruments.

Passenger furnishing

The reliability and comfort of civil aircraft cabin affect the most intuitive feelings of passengers, and are also the main indicators to measure the economy of civil aircraft. Aircraft design engineers often have the subconscious of "technology first", and the neglect of customer demands causes very serious problems (affecting design cost, schedule, market reputation, etc.). The main purpose of passenger furniture is to provide a comfortable and convenient environment for passengers, including passenger seat, flight attendant seat, pilot adjustable seat, filter and anti light shutter. Toilet, kitchen and wardrobe cloakroom.

The toilet and kitchen are located in the middle of the passenger compartment and passenger compartment (as shown in Figure 1.4).

The toilet is on the left and the kitchen is on the right. The rest of the plane has two kitchens and three bathrooms. The toilet is equipped with a liquid water tank, a water vacuum toilet, and a wash basin.

There are three first aid kits on board (one in the engine room, one contained in the collision equipment structure and one at the tail). Emergency equipment includes ropes, oxygen masks, smoke masks, oxygen devices, artificial fire extinguishers, first aid kits, axes, emergency radio and radio beacons, evacuation light signs, emergency lighting and life jackets.

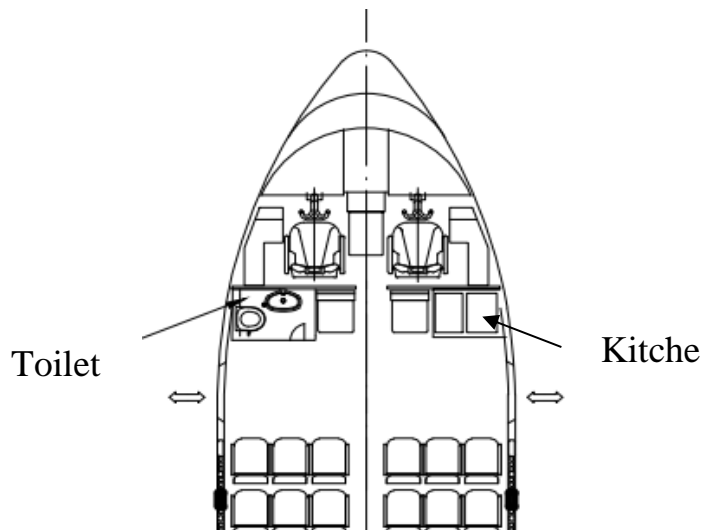

Figure 1.4 – layout of fore part of cabin

Control system

Most aircraft can adapt to the reform of autopilot technology and successfully establish a relatively perfect automatic flight control system, which can better repair the defects between controllability and stability. The automatic airborne control system improves the stability and control of all flight modes from take-off to landing. During the climb phase, the aircraft is automatically controlled by the signals of the complex air navigation system. The aircraft control system operates accordingly in the following modes:

A steering control mode, which is controlled by the aircraft in which the first or second pilot moves through the normal joystick;

Semi-automatic control mode: the pilot commands the position of instruments or other navigation flight instruments

Automatic control mode: the aircraft is controlled by the combination of automatic system and flight navigation complex. The command post is installed on the consoles of the first and second pilots, and each pilot's seat can be controlled by two pilots at the same time or separately.

Landing gear

The landing gear is an accessory device used in the lower part of the aircraft,

which is used to support the aircraft during takeoff and landing or ground (water) taxiing and ground (water) movement. It is the only component supporting the entire aircraft. Its performance is directly related to the safe use of aircraft. In the process of aircraft taxiing, due to the effect of external ground excitation, the front wheels deviate from the neutral position. In order to adapt to aircraft takeoff, landing and taxiing and ground taxiing, the lower end of the landing gear is equipped with wheels with pneumatic tires. In order to shorten the landing distance, the wheels are equipped with brakes or automatic brakes. It also includes a force support strut, a shock absorber (usually used as a shock absorber external barrel), a receiver system, a front wheel swing reducer, and a turning mechanism. Figure 1.5 shows the landing gear structure of the prototype Boeing 757.



Figure 1.5 – landing gear on Boeing 757

The support pillars connect the wheels and shock absorbers to the body and transfer the impact loads from landing and taxiing to the body. The front wheel slewing reducer is used to eliminate the pendulum vibration of the front wheel during high-speed sliding. The front wheel steering mechanism increases the flexibility of aircraft turning on the ground.

Shock absorber: when the aircraft is grounded or running at high speed on an uneven runway, it will have a severe impact on the ground, and most of the impact energy will be absorbed by the shock absorber, except for the small cushioning effect

of pneumatic tires. The aircraft uses oil and gas shock absorbers. It can effectively absorb the impact energy received in the process of aircraft taking off, landing and taxiing, and convert it into heat energy for dissipation.

Usually, the nose gear is the forward income of the nose fuselage. The main landing gear retracts towards the chord.

The main functions of hub are hub and tire. Its main functions are to support the weight of aircraft on the ground, reduce the resistance of aircraft ground motion, and absorb some impact kinetic energy during aircraft landing and ground motion.

The main landing gear is equipped with brakes, which can be used to shorten the flight distance of aircraft landing and make the aircraft have good maneuverability on the ground. Disc type is adopted, which is mainly characterized by large friction area, large heat capacity and convenient maintenance.

The turning system guides the aircraft to turn to the ground, and turns the aircraft through a single brake on the main wheel or by adjusting the thrust (pull) of the left and right engines.

1.2 Geometry calculations for the main parts of the aircraft

1.2.1. Wing geometry calculation

Geometrical characteristics of wings are defined by the takeoff mass m_0 and wing loading p_0 .

Wing area is:

$$S_{wing} = \frac{m_0 \cdot g}{p_0} = \frac{116422 * 9.8}{5557} = 205.32 [m^2] \quad (2.1)$$

Wing span is:

$$l = \sqrt{A_w * A_r} = \sqrt{205.32 * 7.80} = 40 [m] \quad (2.2)$$

Because:

$$\frac{S_{wing}}{2} = (b_o + b_t) * \frac{span}{2} = \frac{205.32}{2} \quad (2.3)$$

$$TR = \frac{b_o}{b_t} = 4.11 \quad (2.4)$$

So, root chord is:

$$b_o = 8.26[m] \quad (2.5)$$

Tip chord is:

$$b_t = 2.01[m] \quad (2.6)$$

There are two methods to calculate the mean aerodynamic chord, and the method I choose is that determined by chord of root, and chord of tip. Then draw the sketch of it.

Mean aerodynamic chord is equal:

$$b_{mac} = \frac{2(b_o^2 + b_o b_t + b_t^2)}{3(b_o + b_t)} = 5.76 [m] \quad (2.7)$$

Determination of mean aerodynamic chord is shown in the Fig1.6.

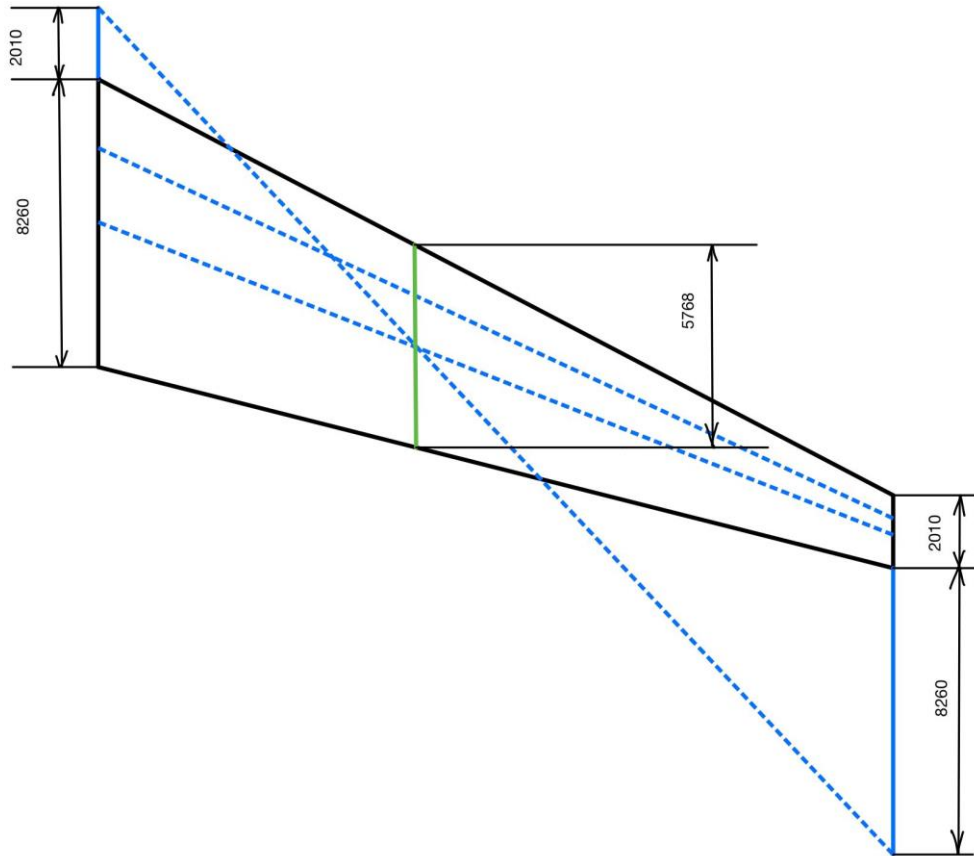

Figure 1.6 – Determination of mean aerodynamic chord

After determining the geometry of the wing, we began to estimate the wing geometry and the high-lift device.

Aileron geometry are determined in the next calculation formulas:

Aileron span:

$$l_{ail} = (0.3 \dots 0.4) * \frac{l_{wing}}{2} = 0.35 * \frac{40}{2} = 7.5 [m] \quad (2.8)$$

Aileron area:

$$s_{ail} = (0.05 \dots 0.08) * s_{wing} = 0.05 * \frac{205.32}{2} = 5.13 [m^2] \quad (2.9)$$

Before the following calculations can be made, the type of airfoil must be selected according to the airfoil catalog, specifying the value of the lift coefficient $C_{y \max bw}$ and determining the necessary increase in the coefficient $C_{y \max}$ of the

high-lift devices outlet by the formula:

$$C_{y \max bw} = \frac{C_{y \max l}}{C_{y \max bw}} \quad (2.10)$$

Where $C_{y \max l}$ is necessary coefficient for the aircraft landing insurance to lift the force in the wing landing configuration (the aircraft parameters are determined during the selection process).

High lift device coefficient is 1.16

Chose triple slotted Faylers flaps with together with slats.

$$b_f = 0.3 \dots 0.4$$

$$b_{\text{flap}} = (0.3 \dots 0.4) b_w = 0.3 * 20 = 6$$

1.2.2 Fuselage layout

When selecting the shape and size of the cross-section of the fuselage, we need to come from aerodynamic requirements (streamlining and cross section).

The subsonic passenger and cargo aircrafts whose velocity is less than 800, wave resistance does not affect it. Therefore, we should select the conditions from the list values friction resistance C_{xf} and profile resistance C_{xp} .

During the transonic and subsonic flights, the shape of the nose part of the fuselage affects the value of the wave resistance C_{xw} . The application of the circular part of the nose of the fuselage significantly reduces its wave resistance.

Passenger number is 186.

Diameter of fuselage is $D_f = 4.2$

Finess ratio of fuselage is $F_R = 9.6$

Fuselage aspect ratio $\lambda_f = 7.80$

The determination of the length of the fuselage takes into account the particularity of the aircraft's scheme, layout and position of the aircraft's center of gravity, as well as the landing angle of attack α_{land} .

The length of the fuselage is equal to:

$$L_f = F_R * D_f = 9.6 * 4.2 = 40.32 [m] \quad (2.11)$$

For the nose part of the transonic aircraft fuselage will be:

$$L_{nfp} = (1.2 \dots 1.5) * D_f = 1.2 * 4.2 = 5.04 [m] \quad (2.12)$$

The length of the fuselage rear part is equal to:

$$L_{frp} = (2 \dots 5) * D_f = 2 * 4.2 = 8.4 [m] \quad (2.13)$$

Cabin:

There is only economy class of aircraft I designed. Economy Class has a total of 186 seats, each lined up in a 3x3 fashion. Select the seat width and aisle width in the different grades of cabin according to the criteria:

Seat width:

The seat width of the economic class is $b_{3chblock} = 1600$.

Aisle width:

And the seat width of the economic class is $b_{aisle} = 600$.

For Economy Class, the seat allocation scheme for each row is (3+ 3), determining the appropriate width of the cabin (Fig.1.7).

The calculated width of Economy Class is equal to:

$$B_{cab} = n_{bl} * b_{3chblock} + n_{aisle} * b_{aisle} + 2 * \mathcal{Z}_1 + 2 * \mathcal{Z}_{wall}$$

$$B_{cab} = 2 * 1600 + 1 * 600 + 2 * 50 + 2 * 100 = 4100 [mm] \quad (2.14)$$

Economy Class

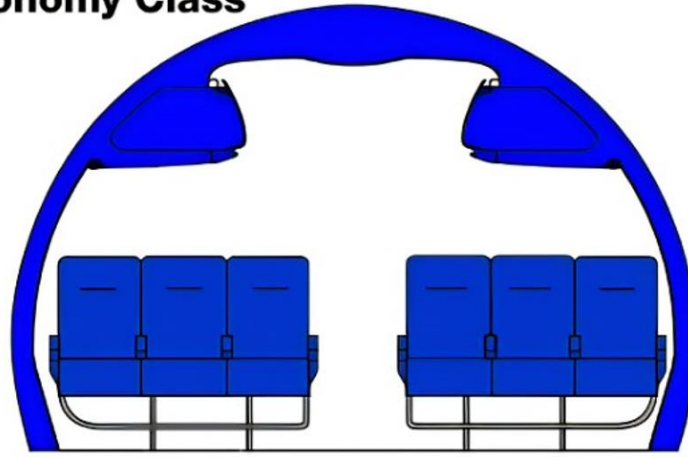

Fig.1.7 – passenger seat in economic class

Length of cabin:

The distance from the forward wall to the seat is 1200mm, and the distance from the back of seat to the wall is 250mm.

Seat pitch of the long-range flight plane in economic class is 870mm

The number of the seats in the economic class is 186, and there are 31 rows of seats blocks.

$$\begin{aligned} L_{eco\ cabin} &= 1200 + 750(n_f - 1) + 250 = 1200 + 870(31 - 1) + 250 \\ &= 23950[\text{mm}] \end{aligned} \quad (2.15)$$

The length of passenger cabin is equal:

$$L_{cabin} = L_{eco\ cabin} = 23.95[m] \quad (2.16)$$

1.2.3 Galleys and buffets

International standards dictate that the aircraft has a mixed layout and must make two dishes. Kitchen cabinets must be placed at the door, preferably with separate doors between the cockpit and passengers or cargo. Refreshments and food cannot be placed near toilet facilities or connected to wardrobes.

Volume of galleys is equal to:

$$V_g = (0.1 \dots 0.2) * n_{pas} = 0.1 * 186 = 18.6[m^3] \quad (2.17)$$

$$h_{ecb} = 1.48 + 0,17 * b_{cabin} = 1.48 + 0.17 * 4.1 = 2.2[m] \quad (2.18)$$

$$h_{ecb} = 0.296 + 0.383 * D_F = 0.296 + 0.383 * 4.2 = 1.90[m] \quad (2.19)$$

Area of galleys is equal to:

$$S_{galley} = \frac{V_g}{H_{cabin}} = \frac{18.6}{1.90} = 9.79[m^2] \quad (2.20)$$

1.2.4 Lavatories

The number of toilet facilities depends on the number of passengers and flight time:

The flight time is more than 4 hours, and one toilet is used to serve 40 passengers. At the same time, referring to the prototype, one toilet is provided for 40 passengers, so the number of toilets is 4

Area of lavatory:

$$S_{lav\ total} = (0.035 \dots 0.04) * n_{pas} = 0.035 * 186 = 6.51[m^2] \quad (2.21)$$

$$S_{lav} = \frac{S_{lav\ total}}{4} = \frac{6.51}{4} = 1.6[m^2] \quad (2.22)$$

The width of the toilet is set as 1m, the length is 1.6m. Compared with the prototype, the design of the toilet is similar and meets the requirements.

1.2.5 Calculation of basic parameters of tail unit

It is a very important task to select the placement position of tail cells. In order to ensure the longitudinal stability under overload, the center of gravity should be placed at the focus in front of the aircraft and the distance between these points, which is related to the average value of the aerodynamic chord of the wing and determines the vertical stability rate.

$$m_x^{cy} = \bar{x}_T - \bar{x}_F < 0$$

Where m_x^{cy} –is the moment coefficient; \bar{x}_T . \bar{x}_F - center of gravity and focus coordinates. $m_x^{cy} > 0$, the plane is statically instable. In the normal aircraft scheme (tail unit is behind the wing), focus of the combination wing – fuselage during the install of the tail unit of moved back.

Static range of static moment coefficient: horizontal A_{HTU} , vertical A_{VTU} given in the table with typical arm H_{TU} and V_{TU} correlations.

Determination of the tail unit geometrical parameters

Area of vertical tail unit is equal:

①

$$S_{HTU} = (0.18 \dots 0.25) * S_{wing} = 0.20 * 205.32 = 41.06[m^2] \quad (2.23)$$

$$S_{VTU} = (0.12 \dots 0.2) * S_{wing} = 0.18 * 205.32 = 36.96[m^2] \quad (2.24)$$

②

$$A_{HTU} = 0.65 \dots 0.8 \quad A_{VTU} = 0.08 \dots 0.12$$

$$\begin{aligned} L_{HTU} \approx L_{VTU} \approx (2.5 \dots 3.5) * b_{mac} &= (2.5 \dots 3.5) * 5.76 \\ &= 3 * 5.76 = 17.28[m] \end{aligned} \quad (2.25)$$

Area of horizontal tail unit is equal:

$$S_{HTU} = \frac{b_{mac} * S_W}{L_{HTU}} * A_{HTU} = \frac{5.76 * 205.32}{17.28} * 0.65 = 44.49[m^2] \quad (2.26)$$

Area of vertical tail unit is equal:

$$S_{VTU} = \frac{l_W * S_W}{L_{VTU}} * A_{VTU} = \frac{40 * 205.32}{17.28} * 0.08 = 38.02[m^2] \quad (2.27)$$

Take the average data:

$$S_{HTU} = \frac{41.064 + 44.49}{2} = 42.78[m^2] \quad (2.28)$$

$$S_{VTU} = \frac{36.958 + 38.02}{2} = 37.49[m^2] \quad (2.29)$$

Values L_{HTU} and L_{VTU} depend on some factors. First of all, their values are influenced by these factors: the length of the nose and tail parts of the fuselage, sweptback angle of wing and the location of wing, and also by the conditions of stability and control of the airplane.

Determination of the elevator area and direction:

Altitude elevator area:

$$S_{el} = (0.3 \dots 0.4) * S_{HTU} = 0.3 * 42.777 = 12.83[m^2] \quad (2.30)$$

Rudder area:

$$S_{rud} = (0.2 \dots 0.22) * S_{VTU} = 0.2 * 37.489 = 7.50[m^2] \quad (2.31)$$

Choose the area of aerodynamic balance.

$M > 0.75$,

$$S_{abel} \approx S_{abrud} = (0.18 \dots 0.2) * S_{control\ surface} = 0.18 * 12.8331 = 2.30[m^2] \quad (2.32)$$

The area of trim tab:

$$S_{tabs} = (0.18 \dots 0.2) S_{rud} = 0.18 * 7.4978 = 1.35[m^2] \quad (2.33)$$

Determine the TU span.

TU span is equal to:

$$L_{ro} = 0.4l_w = 0.4 * 40 = 16[m] \quad (2.34)$$

The height of vertical tail unit is determined by:

$$h_{bo} = 0.2l_w = 0.2 * 20 = 8[m] \quad (2.35)$$

Tapper ratio of horizontal and vertical is chosen by $M < 1$, $\eta_{htu} = 2.5$, $\eta_{vtu} = 1.2$

Determination of TU chords b_{mac} , b_{root} , b_{tip}

For horizontal TU:

$$b_{tip} = \frac{2S_{htu}}{(\eta_{htu} + 1)L_{ro}} = \frac{2 * 42.777}{(2.5 + 1) * 16} = 1.52[m] \quad (2.36)$$

$$b_{mac} = 0.66 \frac{\eta_{htu}^2 + \eta_{htu} + 1}{\eta_{htu} + 1} * b_{htutip} \quad (2.37)$$

$$b_{mac} = 0.66 * \frac{2.5^2 + 2.5 + 1}{2.5 + 1} * 1.25 = 2.51[m] \quad (2.38)$$

$$b_{root} = b_{tip} * \eta_{htu} = 1.25 * 2.5 = 3.13[m] \quad (2.39)$$

For vertical TU: 37.489. For subsonic plane, the horizontal and vertical TU is $\bar{C}_{TU} = 0.08$. TU sweptback is 40° .

1.2.6 Landing gear design

It is the primary stage of this design, and the center of gravity is not defined yet as well as the overall view of the aircraft. Therefore, only the parameters of the landing gear can be defined. As shown in Figure 1.8, the layout of nose gear and main gear on the fuselage can be seen.

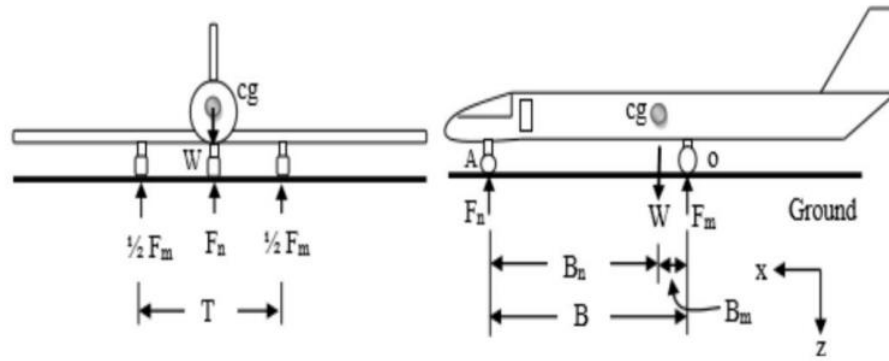

Figure 1.8 – layout of landing gear

Distance from center of gravity to main LG is equal:

$$B_m = 0.2 * b_{MAC} = 0.2 * 5.76 = 1.15[m] \quad (2.40)$$

Due to the long distance, the lifting of the nose gear during the take off process is complex, and due to the small distance, when the rear loading of the aircraft comes first, the impact of the tail of the aircraft is possible. In addition, LG's nose load will be too small and the aircraft will be unstable, operating on smooth runways and side winds. Wheel base is determined by the load proportion that nose and main landing gear take and center of gravity[3].

$$B = 0.3l_f = 12.10[m] \quad (2.41)$$

The last equation means that the nose landing gear carries 6...10% of aircraft weight.

Front wheel axial offset will be equal:

$$B_n = B - B_m = 12.096 - 1.152 = 10.94[m] \quad (2.42)$$

Wheel track is:

$$T = 0.7 * B = 0.7 * 12.096 = 9.88 \leq 12[m] \quad (2.43)$$

To prevent the side nose-over, the value T should be more than two times of the distance from runway to the center of gravity [4]. Therefore, the T value

should be $> 2H$.

where H – the distance from the center of gravity to the runway

$$F_{main} = \frac{(B - B_m) * m_0 * 9.8}{B * n * Z} = \frac{(16.128 - 1.152) * 116422 * 9.81}{16.128 * 2 * 4}$$

$$F_{main} = 132565.16[N] \quad (2.44)$$

$$F_{nose} = \frac{B_m * m_0 * 9.8 * K_g}{B * Z} = \frac{1.152 * 116422 * 9.81 * 1.5}{16.128 * 2}$$

$$F_{nose} = 61183.92[N] \quad (2.45)$$

Where n and z are the quantity of the supports and wheels on the one leg.

$K_g = 1.5$ is dynamics coefficient.

The size and type of tires are shown in the table 1.2.

Table 1.2 – Aviation tires for designing aircraft

Main gear		Nose gear	
Tire size	Ply rating	Tire size	Ply rating
H40 x 16.0-19	24	H31 x 13.0-12	20

1.2.7 Choice and description of power plant

The Rolls-Royce RB211 is a British family of high-bypass turbofan engines made by Rolls-Royce. The engines are capable of generating 41,030 to 59,450 lbf (182.5 to 264.4 KN) of thrust. The RB211 engine was the first production three-spool engine, and turned Rolls-Royce from a significant player in the aero-engine

industry into a global leader. There are some series of this engine we can take in account, for example: Rolls-Royce RB211-535, Rolls-Royce RB211-524G, Rolls-Royce RB211-524B. The follow table 1.3 is the example of these applications [5].

Table 1.3 – Examples of application of Rolls-Royce RB211

Model	Thrust	Bypass ratio	Dry weight
Rolls-Royce RB211-535	42,540 lbf 189.2 KN	4.4:1	8,169 lb 3,705 kg
Rolls-Royce RB211-524G	56,870 lbf 253.0KN	4.3:1	12,540lb 5,688 kg
Rolls-Royce RB211-524B	49,120 lbf 218.5 KN	5:1	11,000 lb 4,990 kg

After comparison, RB211-535 with small weight but meeting the thrust requirements of the aircraft is selected. The engine's improvements also include the use of new materials, such as single crystal turbine blades used in high-pressure turbines [6].

1.3 Center of gravity calculation

The aircraft is not a single body but a multi-object system composed of many objects. The resultant force of gravity of aircraft components, fuel, crew and cargo is called the gravity of the aircraft, and its focus is called the center of gravity (CG). There are many factors that will affect the center of gravity of the aircraft, not only the mass, but also the mass displacement will change the center of gravity. During flight, the center of gravity of the aircraft will always change due to fuel consumption. To calculate the center of gravity, we must first find the mass displacement. We divide the aircraft mass into two parts: the wing mass of the equipment and the fuselage mass of the equipment.

1.3.1 Trim sheet of equipped wing

The mass of the wing includes the mass of the wing structure, the mass of various systems and the mass of fuel. The mass of the main landing gear and the nose landing gear is included in the wing, no matter where they are installed (on the wing or fuselage). In table 4.1, there should be the names of all objects, their masses, their

center of gravity coordinates and moments. The origin of the barycentric coordinates of all objects is defined by the mean aerodynamic chord. After selecting this point, we can build an axis that determines the position of the object.

The positive direction of the coordinates is the end of the aircraft. The information of objects is given in the table 1.4

Table 1.4 - Trim sheet of equipped wing

object name	Mass		C.G coordinate s Xi, m	Mass moment, Xi * mi
	units%	total mass m(i)		
wing (structure)	9.10	10594.40	2.59	27460.69
fuel system	1.03	1199.15	2.59	3108.19
airplane control, 30%	0.15	178.13	3.46	615.60
electrical equipment, 30%	0.92	1072.25	0.58	617.61
anti-ice system , 70%	1.41	1638.06	0.58	943.52
hydraulic systems , 70%	1.02	1189.83	3.46	4112.06
power plant	9.20	10705.00	-2.00	-21410.01
equipped wing without landing gear and fuel	22.83	26576.81	0.58	15447.67
nose landing gear	0.40	465.11	-9.22	-4286.42
main landing gear	3.60	4185.95	2.88	12055.54
fuel	30.80	35862.63	1.10	39448.90
total	57.63	67090.51	0.93	62665.70

1.3.2 Trim-sheet of the equipped fuselage

The coordinate origin is selected as a projection of the nose of the fuselage on the horizontal axis. The example list of the equipped fuselage is shown in the table 1.5.

The CG coordinates are determined by the next formula:

$$X_f = \frac{\sum m_i X_i}{\sum m_i} = 20.80[m] \quad (2.46)$$

After determined the C.G. of the fully equipped wing and fuselage, we construct the moment equilibrium equation relatively to the nose of fuselage:

$$m_F X_f + m_W (X_{MAC} + X_W) = m_0 (X_{MAC} + C) \quad (2.47)$$

Then we determined the wing MAC leading edge position relative to fuselage, and X_{MAC} is determined by the formula:

$$X_{MAC} = \frac{m_f X_f + m_w X_w - m_0 C}{m_0 - m_w} = 22.31[m] \quad (2.48)$$

Where m_0 – aircraft takeoff mass, kg; m_f – mass of fully equipped fuselage, kg; m_w – mass of fully equipped wing, kg; C – distance from MAC leading edge to the C.G. point, determined by the designer. $C = 0.25BMAC$. For swept wings, angle $X = 30^\circ$, $C = (0,28...0,32) BMAC$

Table 1.5 – Trim sheet of equipped fuselage

objects names	Mass		C.G coordinates Xi, m	mass moment
	units%	total mass		
fuselage	9.80	11411.68	20.16	230059.56
horizontal tail	0.94	1095.53	36.00	39439.12
vertical tail	0.93	1087.38	36.00	39145.73
radar	0.29	337.62	0.50	168.81
radio equipment	0.22	256.13	0.80	204.90

1	2	3	4	5
instrument panel	0.50	582.11	2.00	1164.22
aero navigation equipment	0.43	500.61	2.00	1001.23
lavatory1, galley 1	0.59	681.07	8.00	5448.55
lavatory2, galley 2	0.59	681.07	30.00	20432.06
flight control system 70%	0.36	415.63	20.16	8379.03
hydro-pneumatic sys 30%	0.44	509.93	28.22	14392.22
electrical equipment ,70%	2.15	2501.91	20.16	50438.48
not typical equipment	0.35	407.48	20.16	8214.74
lining and isulation	0.58	675.25	20.16	13612.99
anti-ice and airconditioning system	0.60	702.02	20.16	14152.82
passenger seats (economic class)	1.07	1240.00	25.00	31000.00
seats of flight attendance	0.13	150.00	5.00	750.00
seats of pilot	0.03	64.00	3.00	192.00
emergency equipment	0.02	28.00	38.00	1064.00
additional equipment	2.84	3309.88	10.00	33098.77
equipped fuselage without payload	22.8	26637.30	19.23	512359.23
passengers(economic class)	12.3	14322.00	25.00	358050.00
on board meal	0.30	350.00	5.00	1750.00
baggage	5.75	6700.00	10.00	67000.00
cargo, mail	0.69	800.00	10.00	8000.00
crew	0.47	550.00	5.00	2750.00
TOTAL	42.3	49359.30	19.24	949909.23

1.3.3 Calculation of center of gravity positioning variants

The list of mass objects for center of gravity variant calculation given in Table 1.6 and Center of gravity calculation options given in table 1.7, completes on the base of both previous tables.

Table 1.6 – Calculation of C.G. positioning variants

Name object	mass in kg mi	coordinate Xi, m	mass moment kg m
equipped wing (without fuel and landing gear)	26576.81	20.35	540890.82
Nose landing gear (extended)	465.11	6.50	3023.19
main landing gear (extended)	4185.95	22.63	94719.74
fuel of flight	35862.63	24.76	887958.79
equipped fuselage (without payload)	26637.30	19.23	512359.23
passengers of economy class	14322.00	25.00	358050.00
on board meal	350.00	20.00	7000.00
baggage	6700.00	20.00	134000.00
cargo	800.00	20.00	16000.00
crew	550.00	5.00	2750.00
nose landing gear (retracted)	465.11	6.50	3023.19
main landing gear (retracted)	4185.95	18.60	77841.98
fuel reserve	4063.13	20.87	84800.46

Table 1.7 – Airplanes C.G. position variants

NAME	MASS m_i , kg	mass moment m_i, X_i	center of mass X_{CT}	
take off mass (L.G. extended)	120512.94	2556751.77	21.22	0.25
take off mass (L.G. retracted)	120512.94	2539874.01	21.08	0.23
landing weight (LG extended)	84650.30	1753593.45	20.72	0.16
ferry version (without payload, max fuel, LG retract)	94277.81	2024824.01	21.48	0.30
parking version (without pay load, fuel, LG extended)	55779.39	1194032.54	20.63	0.15

Conclusions to the main part

Based on the prototype Boeing 757, the most suitable parameters were selected for the aircraft I designed, taking into account the operation purpose, the number of passengers, the flight distance and speed, as well as the altitude, takeoff and landing conditions. For the main structures, the geometric calculation is carried out through the aerodynamic formula, and their various data are determined, such as wing, fuselage, tail, toilet, kitchen and landing gear.

the design and calculation of the main geometrical parameters of the nose landing gear and main landing gear;

the calculation of the center of gravity of the aircraft;

the choice of the wheels on landing gear and engines.

For main landing gear tyres, H40 is selected \times 16.0-19, level 24; Select H31 for nose gear \times Level 13.0-12 is 20. The engine shall be selected according to the thrust required for aircraft take-off of 173.99kn. When rollsroyce RB211-535 is selected, the thrust can reach 189.2kn, which well meets the requirements the design of aircraft cabin for first class passengers and economic class passengers;

After all of these, we should confirm that anything is in the limitation, to ensure that the aircraft is able to be designed.

2. PASSENGER SEAT DESIGN

2.1 Introduction

Seats play an important role in protecting passengers from accidents and providing good riding experience for members. The design of aviation seats should first be light and reliable, since there are three people in a block of seat. In an emergency, such as forced landing, three people tied to their seats, which should be able to withstand a massive impact. Then, the comfortable experience is also important.

The safety of aircraft seats is an important factor in the whole design. The manufacturing of air passenger seats uses metal, alloy, composite materials, plastics, coatings and other main materials, involving a variety of manufacturing processes and material forming technologies, and has strict requirements on the density, waterproof, flame retardant, toxicity, stiffness and strength of materials. The research and development of new materials need to effectively control weight and absorb dynamic energy on the basis of ensuring structural strength; Reduce design complexity; Control wear and fatigue, and improve the service life of materials.

In 1981, the FAA requires aircraft manufacturers to install seats with a dynamic load of 16g on the newly manufactured aircraft in order to allow investments to seats of people in an aircraft crash. (overload g: refers to the ratio of object motion acceleration to gravitational acceleration or multiple of object motion acceleration and gravitational acceleration. Therefore, people often say that the overload value is several overloads or several g's. Overload has a direction that is opposite to the acceleration direction [7].

Comfort is an important criterion for the success of human-computer interaction in ergonomics, and an important test content for the success of civil aircraft design. The seat must provide the maximum comfort for passengers during flight. Therefore,

<i>Department of Aircraft Design</i>			<i>NAU 22 17T 00 00 00 61 EN</i>			
<i>Performed by</i>	<i>Tan Long</i>	<i>Tan Long</i>	<i>Seat design</i>	<i>Letter</i>	<i>Sheet</i>	<i>Sheets</i>
<i>Supervisor</i>	<i>Vlasenko Y.V.</i>				<i>40</i>	<i>59</i>
<i>Adviser</i>				<i>402AF 134</i>		
<i>Stand. contr.</i>	<i>Khizhnyak S.V.</i>					
<i>Head of dep.</i>	<i>Ignatovych S.R.</i>					

the process of creating and producing of seats is very important [8].

On the physiological level, comfort is mainly body comfort, which is mainly related to seat design and riding leg space. Among them, the seat design includes seat height, seat cushion wrapping, seat back adjustment angle and other factors. The most important way to improve body comfort is to carry out ergonomics research, and design the most appropriate seat through analysis and Research on human sitting posture, seat pressure, seat adjustability, etc.

Comfort at the psychological level is a subjective feeling generated by external objective conditions, such as seat color matching, seat shape, etc. For example, the appropriate arc design and color design of the seat can help the seat integrate into the large body environment, set off each other with the streamlined surface, and give people more sense of security.

2.2 Description of the main part of seat

The concept aircraft passenger seat consists of a backrest frame, a seat cushion bottom plate frame, a head restraint frame and a support frame; The armrest on the right side of each seat can be lifted by the turnover structure, and the corresponding electronic and mechanical structures are provided inside to realize the adjustment function; The energy supply battery assembly utilizes space and is installed on the gap of the bottom support framework. The aircraft passenger seat structure layout is shown in Fig.2.1[8].

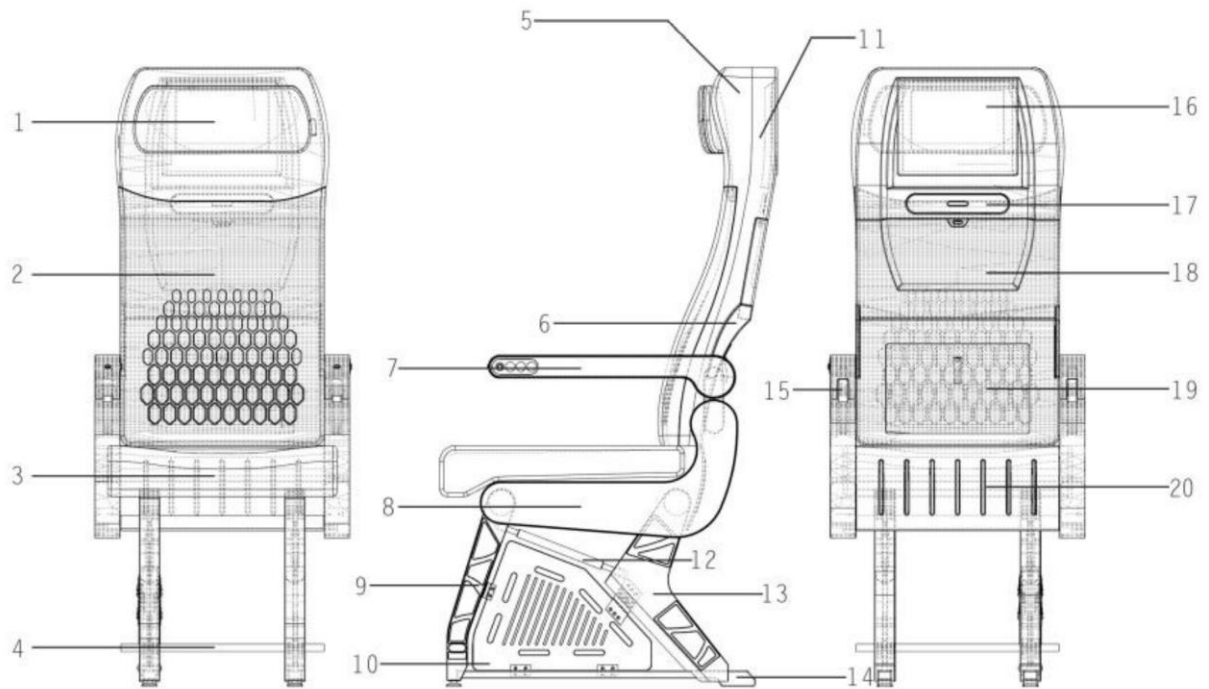

Figure 2.1 – structures of passenger seat

1.seat headrest; 2. Backrest seat cushions; 3. Bottom seat cushion; 4. Baggage bar; 5. backrest frame; 6. small table plate connectors; 7. Armrests; 8. armrest baffle; 9. front support; 10. Battery; 11. seat back panel; 12. support connectors; 13. rear support frame; 14. bottom connection; 15. handrail link shaft structure; 16. IFE screen; 17. wireless charging storage 18. Food tray; 19. magazine bag; 20. rear baffle.

Seat Cushion

The seat cushion is easy to take, so that people can float on the water after a forced landing. In addition, the backrest and cushion are made of polyurethane soft foam, which has smoke suppression. The material has strong flame retardancy and can meet the flame retardant requirements of aircraft seats. No harmful gas is released during combustion or high temperatures.

Armrest Assembly

The structure of armrest is aluminum box, the middle armrest of the aircraft seat row can be connected flush with the backrest to connect multiple seats to a deck chair so that people can lie down.

Life Vest

Under the seat of the aircraft is a life vest. When the plane lands and floats on

the water, you can wear the life jacket. This is "emergency equipment" that should not be removed under normal circumstances.

Baggage Bar (Restraint Tube)

The shape of the luggage bar (restraint tube) assembly is a tube, which is connected to the aisle / outboard spreader and legs through brackets and screws.

Leg Assembly

There are two leg assemblies on leg assembly, and each of them is a machined aluminum leg structure that is bolted to the main frame beam. There is also contains a pivot rear leg assembly that contains stud fasteners with spring-loaded shear rams.

Backrest Assembly

The inclination of the backrest assembly can be adjusted by passengers. The aluminum backrest is mounted on a hook and loop strap attached to the backrest frame. There is a woven bag for storing articles on the rear panel, and the food tray is fixed on the backrest assembly.

Food tray Table Assembly

The food tray table assembly is a vacuum molded ABS plastic table with an aluminum support shaft on the side. The food tray is located at the rear of the backrest assembly. When using the table, the position of the table cannot be changed by tilting the backrest assembly.

Seat assembly attachment

The seat assembly is connected to the aircraft seat rail by fixing the front and rear legs with studs and rail fittings.

2.3 Calculation of seat

According to the previous design, the seat width is 1600mm, and the aisle width is 600mm, as shown in Fig.2.2 As shown in. According to the layout of the seat structure and the ergonomic requirements, the size of the main structure of the seat can be roughly determined.

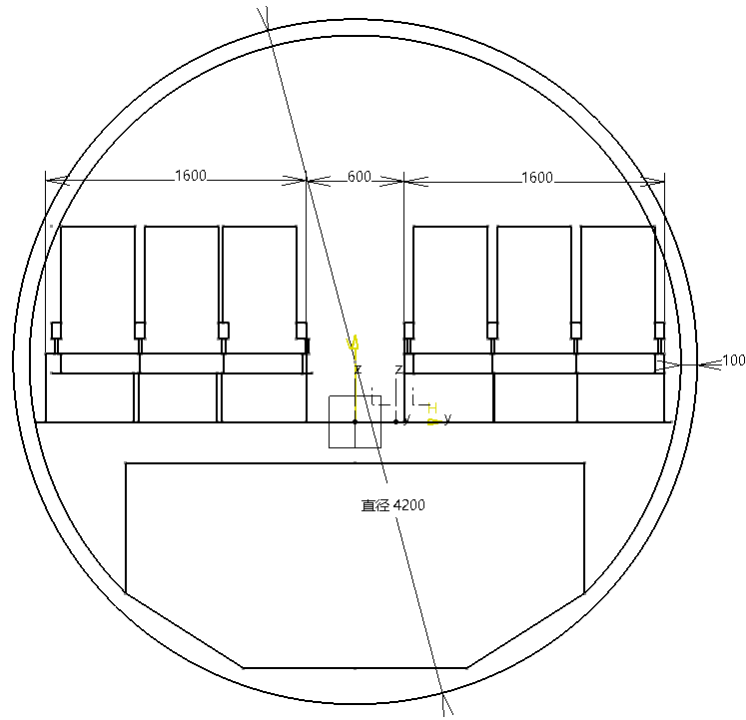

Figure 2.2 – the cross section of economic class

The height of the seat is 1200mm, the length is 600mm, the seat pitch is 750mm, and the maximum inclination angle of the seat shell is about 120 degrees. As shown in the following Fig2.3.

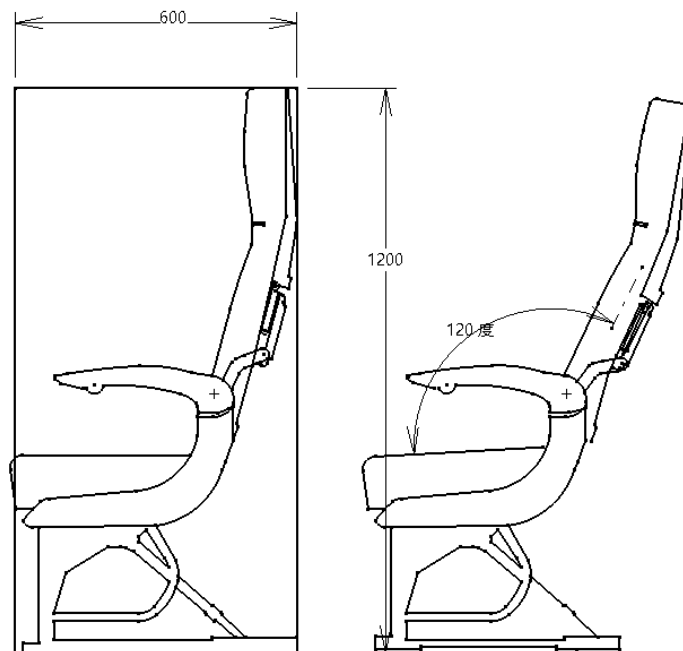

Figure 2.3 –primary dimension of seat

According to the former calculation, and choices from prototype, the dimension of the passenger seat can be chosen. The list of the geometrical parameters of the passenger seats is give in table.

Table 2.1 – dimension of passenger seats

№	Name, Size	Average size	Seat size
1	Distance between the armrest, mm	405~560	510
2	Armrest width, mm	40~81	40
3	Height of armrest above floor, mm	585~670	600
4	Height of the seat cushion above floor, mm	425~457	430
5	Height of seat, mm	1120~1250	1200
6	Seat pitch, mm	750~895	750
7	Width of the block from three seats, mm	1430~1650	1600
8	Mass of the block from three seats, kg	18~20	18

The layout of parts of seat is shown in the Fig.2.3, the angle of the view is from the top, yellow part is the sprayer, and blue part is the leg assembly, the dimension of each part can be seen.

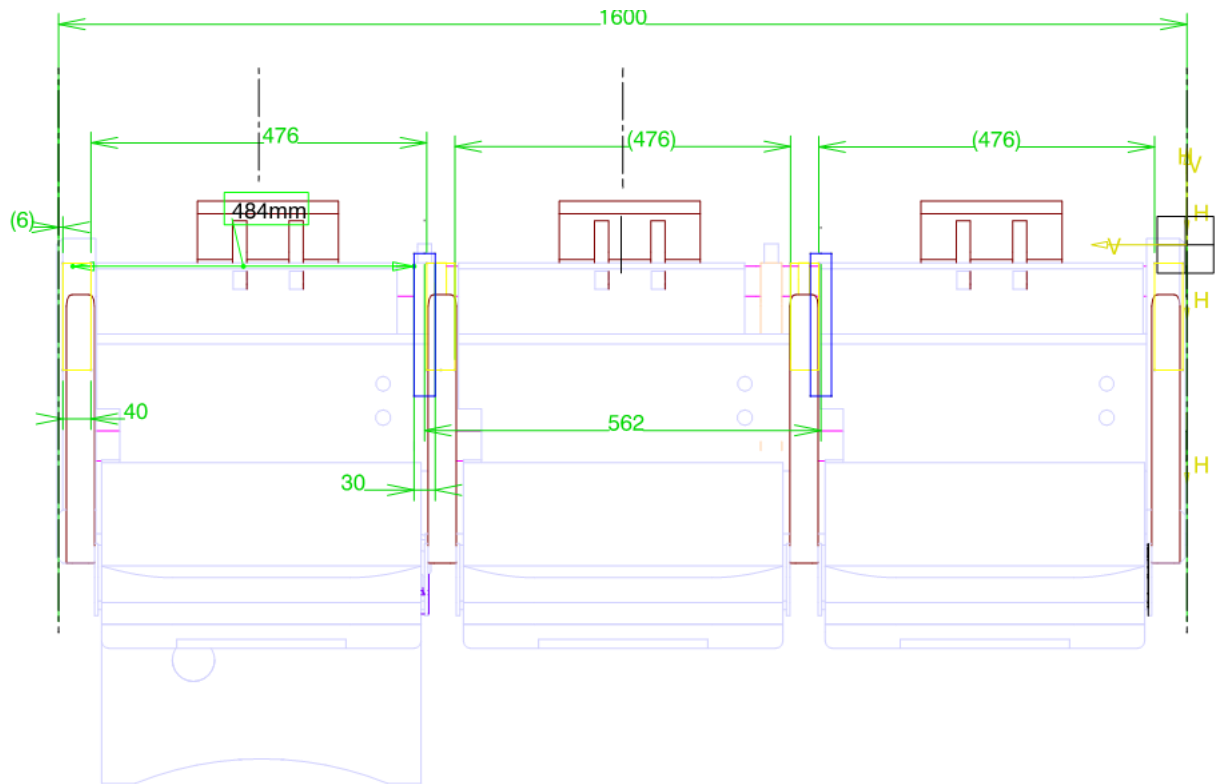
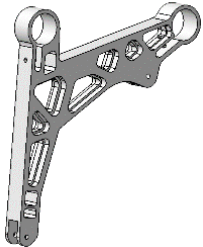

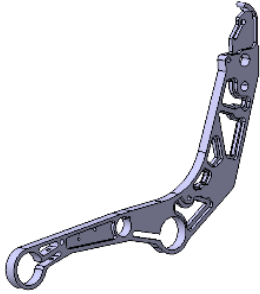
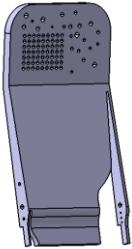

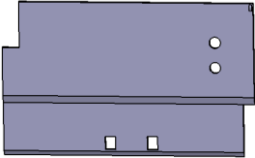

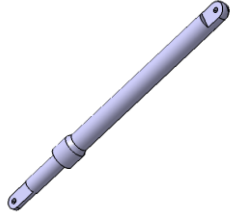

Figure 2.4 –layout of some parts of seat

According to the patent and the geometrical parameters, the leg assembly can be created. The leg is very important to connect the whole seat. Each leg assembly comprising a forward leg portion coupled to the forward base frame tube and the aft base frame tube, wherein a forward surface of the forward leg portion is substantially aligned with a forward edge of the forward base frame tube, and an aft surface of the forward leg portion comprises an angular profile having a shape of an “r”.

The table 2.2 shows each main part of the seat.

Table 2.2 – main parts of passenger seat [9]

№	Name	Snap	Material	Numbers	Thickness (mm)
1	Leg		Aluminum	2	30

1	2	3	4	5	6
2	Spreader		Aluminum	4	20
3	Seat back		Aluminum	3	20
4	Baggage bar		Aluminum	1	Ø20
5	Seat pan		Aluminum	3	10
6	Seat cushion		Polyurethane soft foam	3	-
7	Armrest		Aluminum	4	40
8	load-limiting strut		Aluminum	2	Ø20
9	Base frame tube		Aluminum	2	Ø42

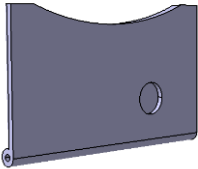
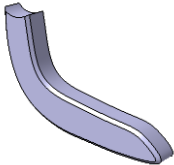
1	2	3	4	5	6
10	Food tray		ABS plastic	3	10
11	bumper		Plastic	2	5

The assembly of the basic part is shown in Fig.2.5, it is included two base frame tube, baggage bar, two leg assembly and two load-limiting strut is connected. The basic structure is attached to the aircraft seat tracks by securing the legs, fore and aft, with studs and track fittings.

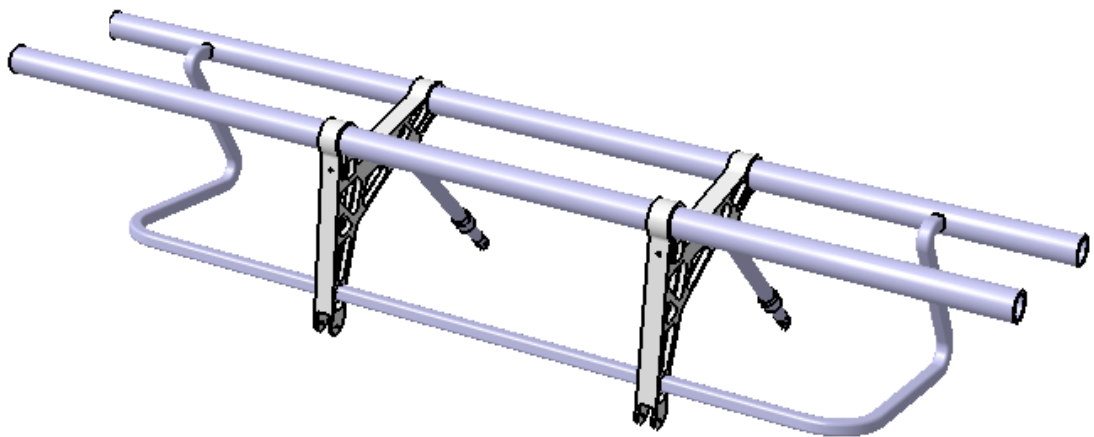

Fig.2.5 –assembly of the basic part of seat

Then, finish the design of other part, the assembly of the seat is shown in Fig.2.6.

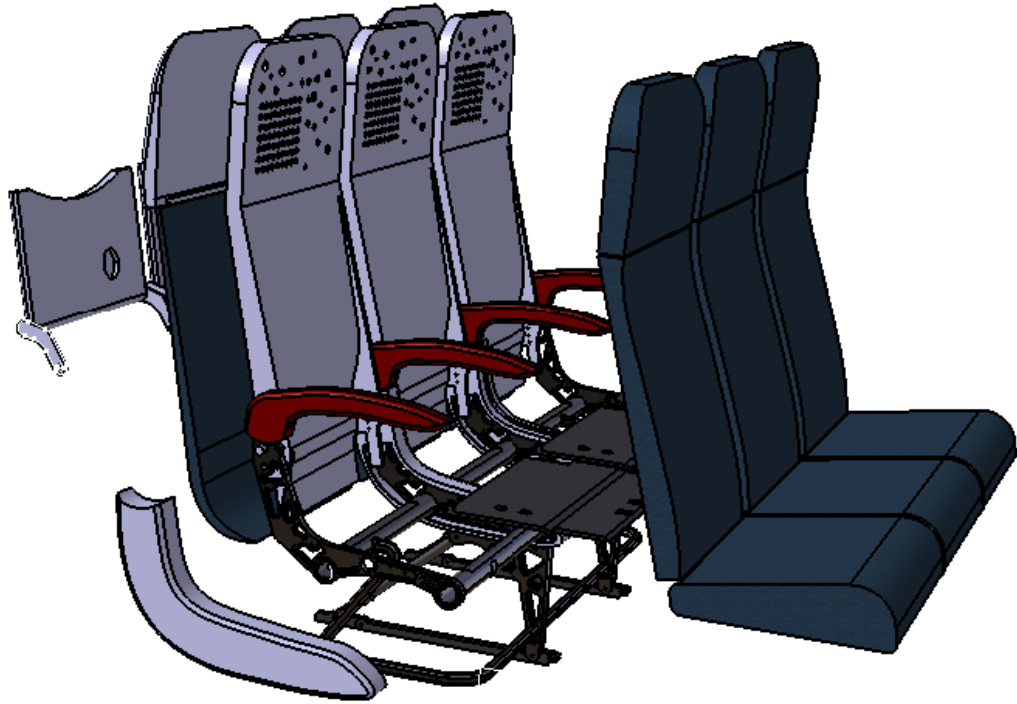

Fig.2.6 –assembly of seat

The seat after assembly is shown in the following picture:



Fig.2.7 –front view of seat

The rear view is shown in the following figure



Fig.2.8 –rear view of seat

2.4 Strength analysis

The material of the main supporting structure of seat is aluminum, the properties of aluminum is shown in Fig.2.9, the Young Modulus is $7e + 010N_m^2$, density of aluminium is $2710kg_m^3$, and yield strength $9.5e + 007N_m^2$.

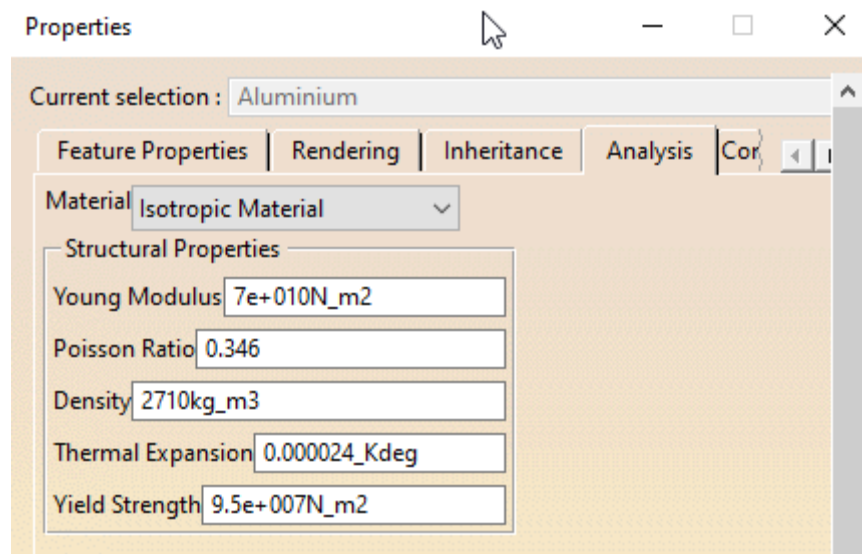

Fig.2.9 –assembly of seat

A leg assembly for mounting passenger seats in transport vehicles especially configured to absorb energy, in the event of a survivable crash or other sudden deceleration [10]. To determine the placement of the leg assembly, a "16 g test" was

performed. When the aircraft seat is still fixed on the fuselage after the specified force is applied, in this case, the test results show that the design of moving the front legs forward relative to the infrastructure provides sufficient structural support for the passenger seat, maximizes the space under the passenger seat, and minimizes the amount of material and component weight.

The following picture is shown the first analysis of leg with 40kg load on the one side of seat. As the result, the stress value at one point is very high, which is easy to cause cracks.

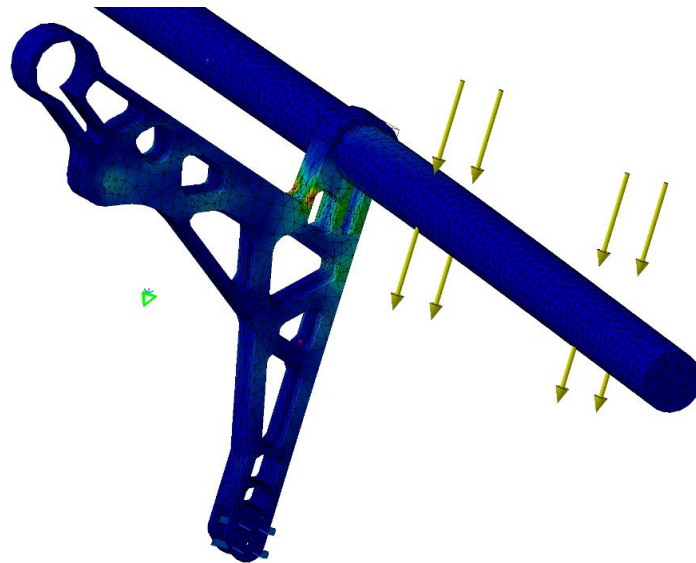

Fig.2.10 –assembly of seat

After modify the width of the structure, the Von Mises stress Maximum is changed. And the value is $6.09e+007$, which is lower than yield strength of aluminum.

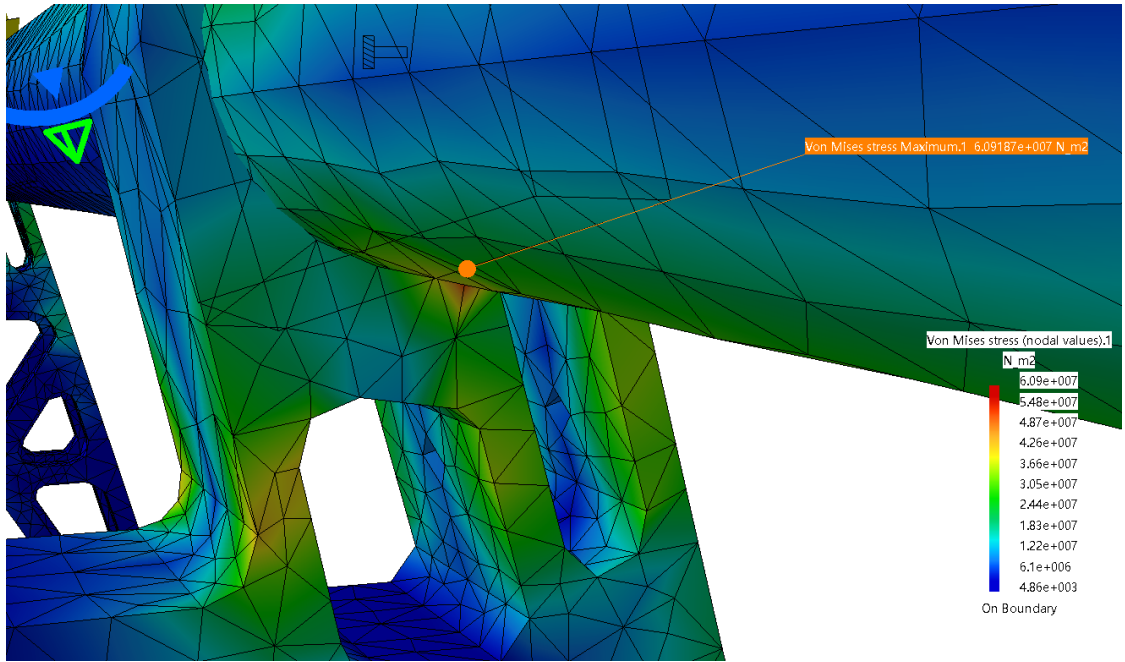

Fig.2.11 –assembly of seat

When three men sit on the seat, each of three parts of seat will bear 800N loads, the Fig.2.12 shows the translational displacement magnitude of two legs connect with two base frame tube with loads. The left has more translational displacement than right, it is because, the seat is connected to the aircraft through the tracks, which is asymmetrically distributed on the floor.

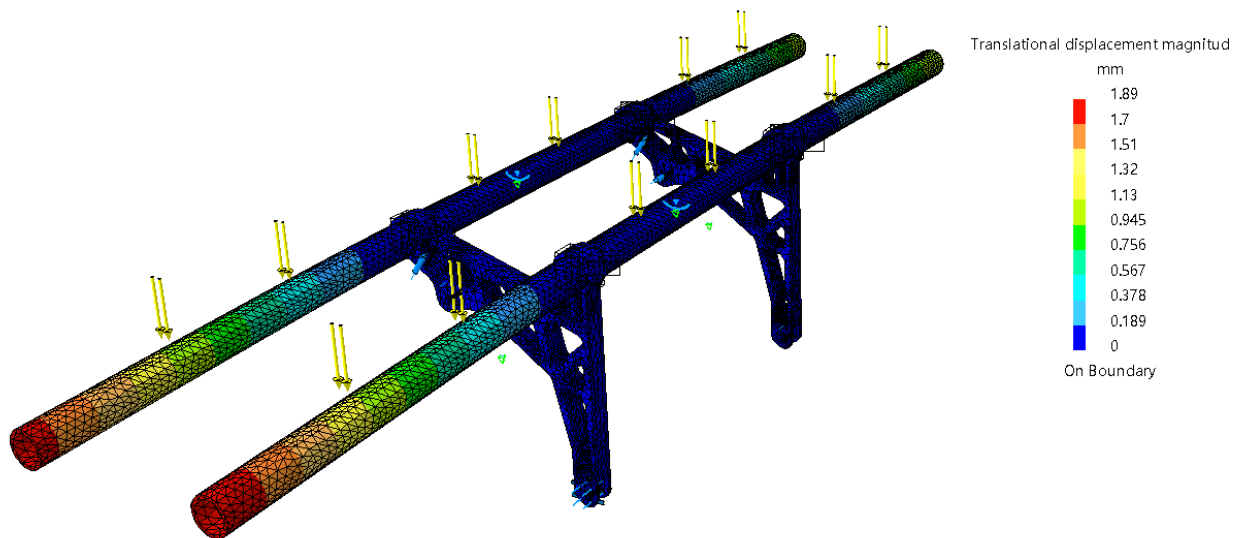

Fig.2.12 –assembly of seat

The Von Mises stress of these four parts is shown in Fig.2.12.

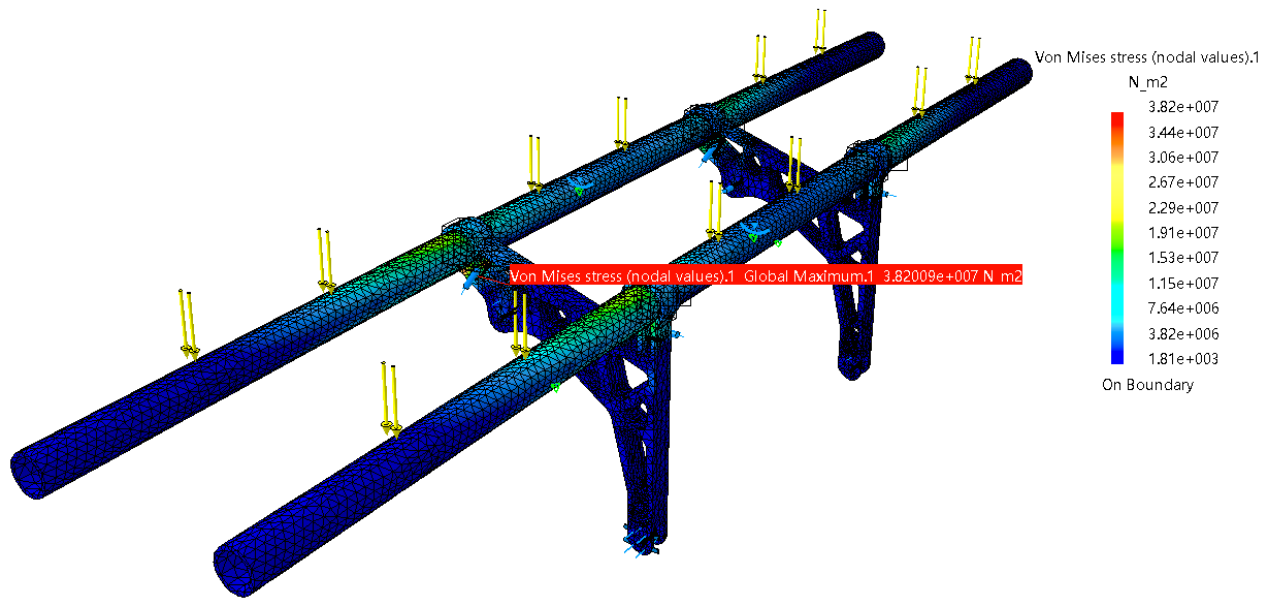

Fig.2.13 –assembly of seat

The front leg portion also includes an aperture through which the luggage bar is inserted. Both ends of the luggage bar are shaped to extend in the backward direction and are coupled to the corresponding ends of the tailstock tube, as shown in the figure. To a certain extent, it can share the force of the rear base tube and maintain the stability of the structure. The Von Mises stress of these five parts is shown in Fig.2.13.

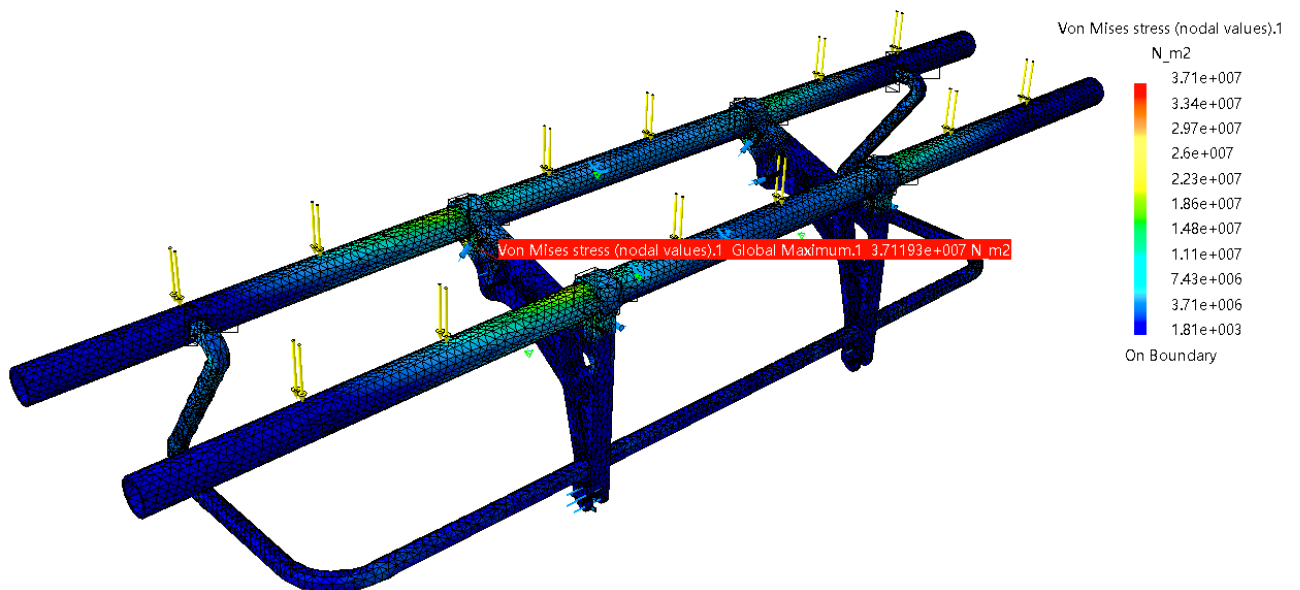

Fig.2.14 –assembly of seat

As shown in the figure, the point with the maximum stress value is at the bolt hole connecting the rear base tube and the leg, and its value is $3.71e+007$.

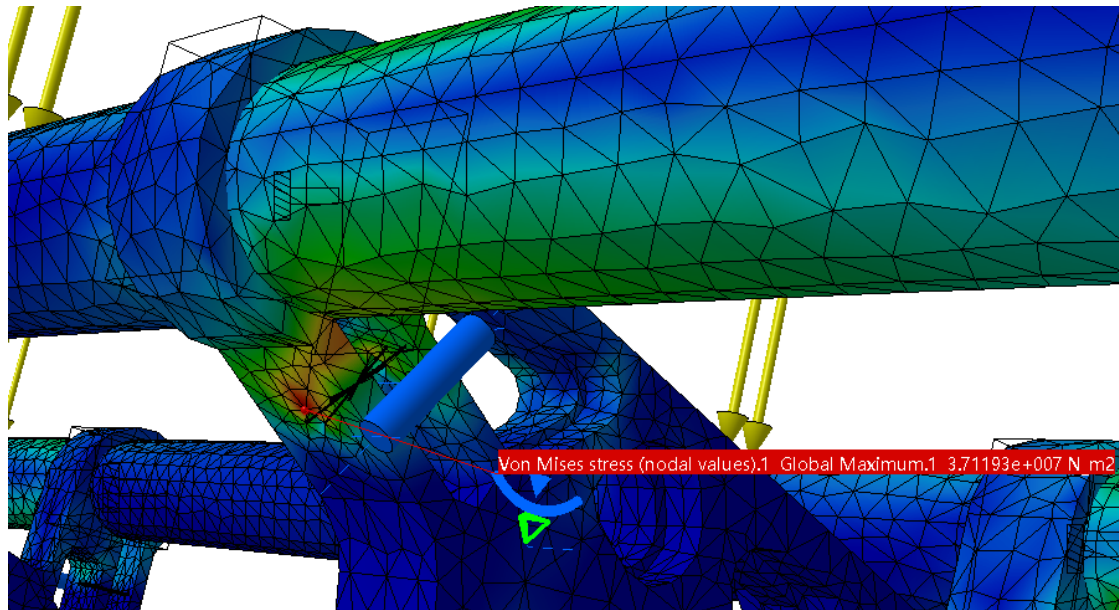

Fig.2.15 –assembly of seat

The load-limiting strut will absorb energy during a crash, it will configured to elongate, to protect passenger seat assembly. The Von Mises stress of these seven parts is shown in Fig.2.16. the point with the maximum stress value is at the bolt hole connecting the rear base tube and the leg, and its value is $3.5e+007$, which is less than former.

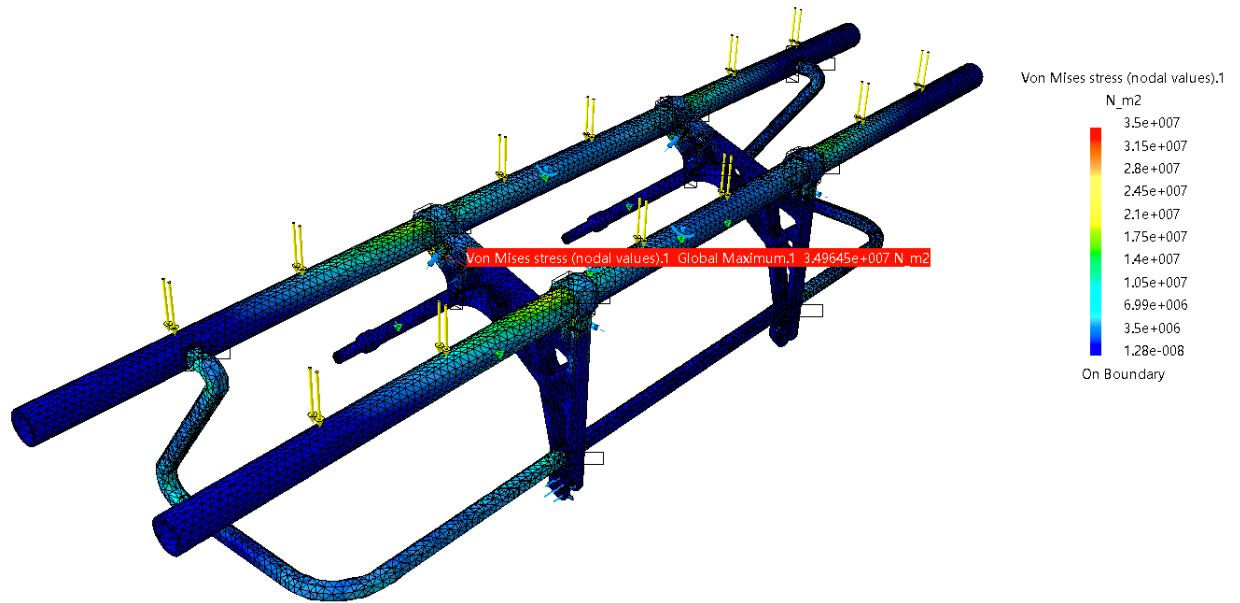

Fig.2.16 –assembly of seat

the translational displacement magnitude of these seven parts is shown in Fig.2.17.

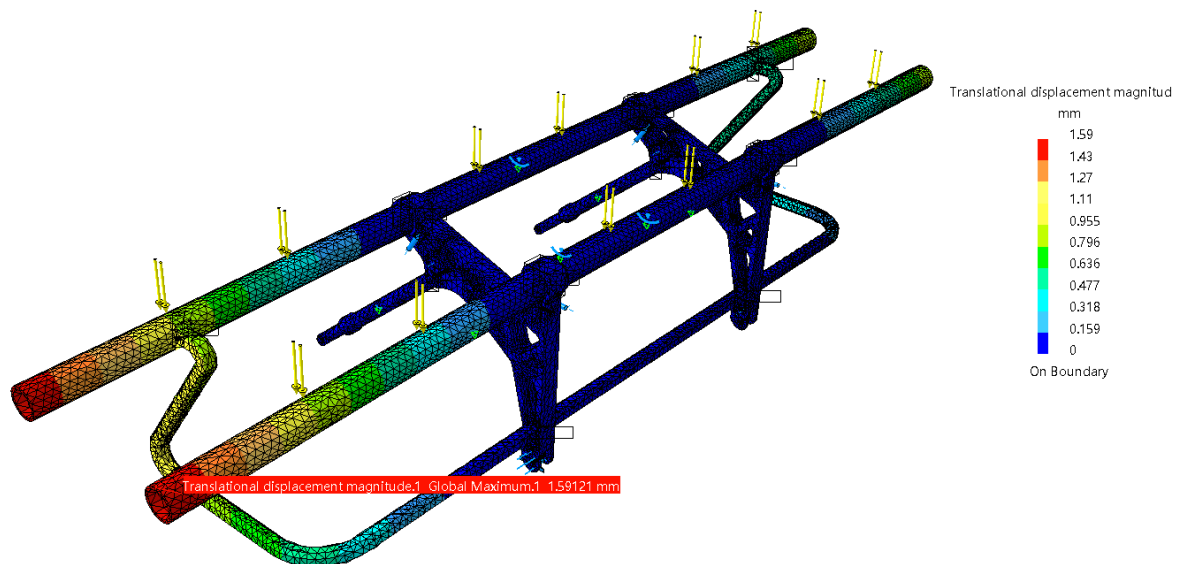

Fig.2.17 –assembly of seat

Conclusions to the special part

The structure of leg assembly and spreader has hollowed out parts because it can reduce the weight without changing the structural strength. Through the strength analysis experiment, it can be found that the basic support structure of the seat is very stable and meets the requirements.

In recent years, with the rapid development of the civil aviation industry, the passenger seat has ushered in a high-quality development stage. During this period, the standards and specifications for passenger seats have been gradually established, the calculation, analysis, manufacturing and test methods have been continuously improved, the airworthiness verification ability has been gradually accumulated, and the high-performance seat materials have been developed. The newly developed seat plays an important role in protecting passengers from accidents and providing good riding experience for members.

References

1. <https://baike.baidu.com/item/%E6%B3%A2%E9%9F%B3757/1692814>
2. 5 Main components of an aircraft [Electronic source] - Access mode URL:
<https://www.sheffield.com/2015/5-main-components-of-an-aircraft.html>
3. Karuskevich M.V., Maslak T.P. «Aircraft. Design». Lectures course «Landing gear» – K:NAU, 2013
4. The Design of strength of aircraft: Lecture course / M.V.Karuskevich, T.P. Maslak. – K. :NAU, 2019
5. <https://baike.baidu.com/item/RB211%E5%8F%91%E5%8A%A8%E6%9C%BA/12014031>
6. CFM56-7B Technology. CFM International Website, 2012.
7. <http://www.cannews.com.cn/2016/0330/150989.shtml>
8. Wikicatia. Airliner seat: website. URL:
https://wikicatia.org/en/Airliner_seat0802428420 (data: 02.05.2)
9. Qiu Jiyao, Xu Jianguhua. Study on passenger seat design of economy class aircraft based on FAST-TRIZ[J]. Design, 2021, 34(21): 145-148.
10. <https://patents.google.com/patent/US5730492A/en?q=US5730492A>
11. US20140375090A1 - Passenger seat - Google Patents

<i>Department of Aircraft Design</i>			<i>NAU 22 17T 00 00 00 61 EN</i>			
<i>Performed by</i>	<i>Tan Long</i>	<i>Tan Long</i>	<i>Reference</i>	<i>Letter</i>	<i>Sheet</i>	<i>Sheets</i>
<i>Supervisor</i>	<i>Vlasenko Y.V.</i>				<i>57</i>	<i>59</i>
<i>Adviser</i>				<i>402AF 134</i>		
<i>Stand. contr.</i>	<i>Khizhnyak S.V.</i>					
<i>Head of dep.</i>	<i>Ignatovych S.R.</i>					

Appendix A

INITIAL DATA AND SELECTED PARAMETERS

Passenger Number	186
Flight Crew Number	2
Flight Attendant or Load Master Number	5
Mass of Operational Items	2162.06 kg
Payload Mass	20050.80kg
Cruising Speed	850 km/h
Cruising Mach Number	0.7966
Design Altitude	11 km
Flight Range with Maximum Payload	7200 km
Runway Length for the Base Aerodrome	2.95 km
Engine Number	2
Thrust-to-weight Ratio in N/kg	3.1
Pressure Ratio	30
Accepted Bypass Ratio	6.00
Optimal Bypass Ratio	6.00
Fuel-to-weight Ratio	0.1700
Aspect Ratio	7.80
Taper Ratio	4.11
Mean Thickness Ratio	0.120
Wing Sweepback at Quarter of Chord	30°
High-lift Device Coefficient	1.1600
Relative Area of Wing Extensions	0.050
Wing Airfoil Type	supercritical
Winglets	no
Spoilers	yes
Fuselage Diameter	4.20m
Fineness Ratio of the fuselage	9.60
Horizontal Tail Sweep Angle	35°
Vertical Tail Sweep Angle	40°

CALCULATION RESULTS

Optimal Lift Coefficient in the Design Cruising Flight Point $C_y=0.45135$

Induce Drag Coefficient $C_x = 0.00911$

ESTIMATION OF THE COEFFICIENT $D_m = M_{critical} - M_{cruise}$

Cruising Mach Number	0.79660
Wave Drag Mach Number	0.80698
Calculated Parameter Dm	0.01038
Wing Loading in kPa (for Gross Wing Area):	
At Takeoff	5.557
At Middle of Cruising Flight	4.562
At the Beginning of Cruising Flight	5.352
Drag Coefficient of the Fuselage and Nacelles	0.00847
Drag Coefficient of the Wing and Tail Unit	0.00915
Drag Coefficient of the Airplane:	
At the Beginning of Cruising Flight	0.02927
At Middle of Cruising Flight	0.02769
Mean Lift Coefficient for the Ceiling Flight	0.45135
Mean Lift-to-drag Ratio	16.29968
Landing Lift Coefficient	1.623
Landing Lift Coefficient (at Stall Speed)	2.435
Takeoff Lift Coefficient (at Stall Speed)	1.984
Lift-off Lift Coefficient	1.448
Thrust-to-weight Ratio at the Beginning of Cruising Flight	0.553
Start Thrust-to-weight Ratio for Cruising Flight	2.342
Start Thrust-to-weight Ratio for Safe Takeoff	2.847
Design Thrust-to-weight Ratio R_o	2.989
Ratio $D_r = R_{cruise} / R_{takeoff}$ D_r	0.823

SPECIFIC FUEL CONSUMPTIONS (in kg/kN*h):

Takeoff	34.8865
Cruising Flight	57.8883
Mean cruising for Given Range	63.2099

FUEL WEIGHT FRACTIONS:

Fuel Reserve	0.03490
Block Fuel	0.30804

WEIGHT FRACTIONS FOR PRINCIPAL ITEMS:

Wing	0.09100
------	---------

Horizontal Tail	0.00941
Vertical Tail	0.00934
Landing Gear	0.03995
Power Plant	0.09195
Fuselage	0.09802
Equipment and Flight Control	0.11679
Additional Equipment	0.00986
Operational Items	0.01857
Fuel	0.34294
Payload	0.17223

Airplane Takeoff Weight M = 116422kg
Takeoff Thrust Required of the Engine 173.99kN

Air Conditioning and Anti-icing Equipment Weight Fraction	0.0201
Passenger Equipment Weight Fraction (or Cargo Cabin Equipment)	0.0129
Interior Panels and Thermal/Acoustic Blanketing Weight Fraction	0.0058
Furnishing Equipment Weight Fraction	0.0117
Flight Control Weight Fraction	0.0051
Hydraulic System Weight Fraction	0.0146
Electrical Equipment Weight Fraction	0.0307
Radar Weight Fraction	0.0029
Navigation Equipment Weight Fraction	0.0043
Radio Communication Equipment Weight Fraction	0.0022
Instrument Equipment Weight Fraction	0.0050
Fuel System Weight Fraction	0.0103

Additional Equipment:

Equipment for Container Loading	0.0064
No typical Equipment Weight Fraction (Build-in Test Equipment for Fault Diagnosis, Additional Equipment of Passenger Cabin)	0.0035

TAKEOFF DISTANCE PARAMETERS

Airplane Lift-off Speed	281.95km/h
Acceleration during Takeoff Run	2.23m/s ²
Airplane Takeoff Run Distance	1311m
Airborne Takeoff Distance	578m
Takeoff Distance	1890m

CONTINUED TAKEOFF DISTANCE PARAMETERS

Decision Speed	267.85 km/h
Mean Acceleration for Continued Takeoff on Wet Runway	0.30m/s ²
Takeoff Run Distance for Continued Takeoff on Wet Runway	2149.39m
Continued Takeoff Distance	2727.77m
Runway Length Required for Rejected Takeoff	2826.12m

LANDING DISTANCE PARAMETERS

Airplane Maximum Landing Weight	86041kg
Time for Descent from Flight Level till Aerodrome Traffic Circuit Flight	21.8min
Descent Distance	51.381km
Approach Speed	246.19km
Mean Vertical Speed	1.99m/s
Airborne Landing Distance	515m
Landing Speed	231.19km/h
Landing run distance	714m
Landing Distance	1230m
Runway Length Required for Regular Aerodrome	2053m
Runway Length Required for Alternate Aerodrome	1746m