

**МІНІСТЕРСТВО ОСВІТИ ТА НАУКИ УКРАЇНИ**  
**Національний авіаційний університет**  
**Кафедра конструкції літальних апаратів**

ДОПУСТИТИ ДО ЗАХИСТУ  
Завідувач кафедри, д.т.н., проф.  
\_\_\_\_\_ Сергій ІГНАТОВИЧ  
« \_\_\_\_ » \_\_\_\_\_ 2023 рік

**КВАЛІФІКАЦІЙНА РОБОТА**  
**ЗДОБУВАЧА ОСВІТНЬОГО СТУПЕНЯ**  
**«БАКАЛАВР»**

**Тема: «Аванпроект пасажирського середньомагістрального літака  
пасажиромісткістю до 110 осіб»**

**Виконала:** \_\_\_\_\_ **Єлизавета ЛЯШЕНКО**

**Керівник: к.т.н, доцент** \_\_\_\_\_ **Вадим ЗАКІЄВ**

**Нормоконтролер: к.т.н, доц.** \_\_\_\_\_ **Володимир  
КРАСНОПОЛЬСЬКИЙ**

**Київ 2023**

**MINISTRY OF EDUCATION AND SCIENCE OF UKRAINE**  
**National Aviation University**  
Department of Aircraft Design

**PERMISSION TO DEFEND**  
Head of the department  
Professor, Dr. of Sc.,  
\_\_\_\_\_ Sergiy IGNATOVYCH  
«\_\_» \_\_\_\_\_ 2023

**BACHELOR DEGREE THESIS**

**Topic: «Preliminary design of a medium range aircraft with  
110 passenger capacity»**

**Fulfilled by:** \_\_\_\_\_ **Yelyzaveta LIASHENKO**

**Supervisor: PhD, associate professor** \_\_\_\_\_ **Vadim ZAKIEV**

**Standard controller:**  
**PhD, associate professor** \_\_\_\_\_ **Volodymyr  
KRASNOPOLSKYI**

**Kyiv 2023**

# НАЦІОНАЛЬНИЙ АВІАЦІЙНИЙ УНІВЕРСИТЕТ

Аерокосмічний факультет

Кафедра конструкції літальних апаратів

Освітній ступінь «Бакалавр»

Спеціальність 134 «Авіаційна та ракетно-космічна техніка»

Освітньо-професійна програма «Обладнання повітряних суден»

## ЗАТВЕРДЖУЮ

Завідувач кафедри, д.т.н, проф.

\_\_\_\_\_ Сергій ІГНАТОВИЧ

«\_\_\_\_\_» \_\_\_\_\_ 2023 р.

## ЗАВДАННЯ

**на виконання кваліфікаційної роботи здобувача вищої освіти**

**ЛЯШЕНКО ЄЛИЗАВЕТИ АНДРІЇВНИ**

1. Тема роботи: «Аванпроект пасажирського середньомагістрального літака пасажиромісткістю 110 осіб», затверджена наказом ректора від 1 травня 2023 року № 624/ст.
2. Термін виконання роботи: з 29 травня 2023 р. по 25 червня 2023 р.
3. Вихідні дані до роботи: максимальна кількість пасажирів 110, дальність польоту з максимальним комерційним навантаженням 5648 км, крейсерська швидкість польоту 828 км/год, висота польоту 11 км.
4. Зміст пояснювальної записки: вступ, збір даних прототипів, розрахунок геометричних характеристик літака, центрування літака, спеціальна частина в якій виконується переобладнання у медичний літак.

5. Перелік обов'язкового графічного матеріалу: загальний вигляд літака (A1×1), компоувальне креслення фюзеляжу (A2×1), креслення переобладнаної версії медичного літака (A1×1).

6. Календарний план-графік:

Завдання	Термін виконання	Відмітка про виконання
Вибір вихідних даних, аналіз характеристик літаків-прототипів	29.05.2023 –31.05.2023	
Вибір та розрахунок параметрів проектованого літака	01.06.2023 –03.06.2023	
Виконання компоування літака	04.06.2023 –05.06.2023	
Розрахунок центрування літака, робота над спеціальною частиною	06.06.2023 –09.06.2023	
Виконання креслень літака	10.06.2023 –11.06.2023	
Оформлення пояснювальної записки	12.06.2023 –14.06.2023	
Подача роботи для перевірки на плагіат	15.06.2023 –18.06.2023	
Попередній захист кваліфікаційної роботи.	19.06.2023	
Виправлення зауважень. Підготовка супровідних документів та презентації доповіді.	20.06.2023 –22.06.2023	
Захист дипломної роботи	23.06.2023 –25.06.2023	

7. Дата видачі завдання: 29 травня 2023 року

Керівник дипломної роботи

\_\_\_\_\_

Вадим ЗАКІСВ

Завдання прийняв до виконання

\_\_\_\_\_

Єлизавета ЛЯШЕНКО

# NATIONAL AVIATION UNIVERSITY

**Aerospace Faculty**

**Department of Aircraft Design**

**Educational Degree “Bachelor”**

**Specialty 134 “Aviation and Aerospace Technologies”**

**Educational Professional Program “Aircraft Equipment”**

**APPROVED BY**

Head of the Department

Professor Dr. of Sc.

\_\_\_\_\_ Sergiy IGNATOVYCH

« \_\_\_ » \_\_\_\_\_ 2023

## **TASK**

for the bachelor degree thesis

**YELYZAVETA LIASHENKO**

1. Topic: «Preliminary design of a medium range aircraft with 110 passenger capacity»
2. Period of work: since 29 May 2023 till 25 June 2023.
3. Initial data: cruise speed 828 km/h, flight range 5648 km, operating altitude 11 km, 110 passengers.
4. Content (list of topics to be developed): introduction, data collection of prototypes, calculation of geometric characteristics of the aircraft, centering of the aircraft, special part in which the conversion into a medical aircraft performed.
5. Required material: general view of the airplane (A1×1); layout of the airplane (A2×1); drawing of converted version of medical aircraft (A1×1).

Graphical materials performed in AutoCAD.

6. Thesis schedule:

Task	Time limits	Done
Task receiving, processing of statistical data	29.05.2023 – 31.05.2023	
Aircraft geometry calculation	01.06.2023 – 03.06.2023	
Aircraft layout	04.06.2023 – 05.06.2023	
Aircraft centering, work on a special part	06.06.2023 – 09.06.2023	
Graphical design of the parts	10.06.2023 – 11.06.2023	
Completion of the explanation note	12.06.2023 – 14.06.2023	
Submission of the work to plagiarism check.	15.06.2023 – 18.06.2023	
Preliminary defense of the thesis	19.06.2023	
Making corrections, preparation of documentation and presentation.	20.06.2023 – 22.06.2023	
Defense of the diploma work	23.06.2023 – 25.06.2023	

7. Date of the task issue: 29 May 2023

Supervisor \_\_\_\_\_

Vadim ZAKIEV

Student \_\_\_\_\_

Yelyzaveta LIASHENKO

## РЕФЕРАТ

Пояснювальна записка кваліфікаційної роботи бакалавра **«Аванпроект пасажирського середньомагістрального літака пасажиромісткістю до 110 осіб»:**

69 сторінок, 14 рисунків, 9 таблиць, 13 літературних посилань, 4 креслення

У цій кваліфікаційній роботі було розроблено проект середньо магістрального пасажирського літака з дотримання усіх міжнародних умов для стандартизації літака, запропоновано переобладнання пасажирського салону під медичний варіант літака.

У даній роботі було залучено комп'ютерне проектування за допомогою програми AutoCAD, розрахунок центрівки пасажирського та медичного літака.

Практичне значення результату дипломної роботи полягає у підтвердженні можливості конвертації розробленого пасажирського літака в медичний варіант.

Матеріали дипломної роботи можуть бути залучені у освітньому процесі та в практичній діяльності для конструкторів спеціалізованих проектних установ.

**Дипломна робота, аванпроект літака, геометричні розрахунки, компонування, центрування пасажирського літака, конвертація у медичний літака**

## **ABSTRACT**

Bachelor thesis «**Preliminary design of a medium range aircraft with 110 passenger capacity**»

69 pages, 14 figures, 9 tables, 13 references, 4 drawings

In this qualifying work, a project of a middle-range passenger aircraft developed in accordance with all international criteria for aircraft standardization, including the design of the passenger cabin conversion for the medical version of the type of aircraft.

This work involved computer-aided design using the AutoCAD program, calculation of the centerline of a passenger and medical aircraft.

The practical significance of the results of the thesis is to confirm the possibility of conversion of developed passenger aircraft into medical version.

The materials of the thesis can be use in the educational process and in practical activities for constructors of specialized design institutions.

**Thesis, aircraft preliminary design, geometric calculations, layout, centering of a passenger aircraft, conversion into a medical plane,**



<i>F o r m a t</i>								
				<u><i>General documents</i></u>				
	A4	1	NAU 23 06L 00 00 00 52 TW	Task for work	1			
		2	NAU 23 06L 00 00 00 52	Mid-range passenger aircraft	1			
	A1		Sheet 1	General view	1			
	A1		Sheet 2	Fuselage layout	1			
	A1		Sheet 3	Medical aircraft layout	1			
	A4	3	NAU 23 06L 00 00 00 52	Mid-range passenger aircraft Explanatory note	68			
				<u><i>Documentation for assembly units</i></u>				
				<i>NAU 23 06L 00 00 00 52 EN</i>				
<i>Ch</i>	<i>Shee</i>	<i>Document №</i>	<i>Sign</i>	<i>Date</i>	<i>Preliminary design of mid-range passenger aircraft with 110 passenger capacity (List of diploma work)</i>	<i>Letter</i>	<i>Sheet</i>	<i>Sheets</i>
<i>Performed Supervisor</i>		Liashenko Y. Zakiev V.					9	68
<i>St.control.</i>		Krasnopolskyi V.S.				<b>AF 402 134</b>		
<i>Head of</i>		Ignatovych S.R.						

## CONTENT

INTRODUCTION.....	12
1. PRELIMINARY DESIGN OF MID RANGE AIRCRAFT.....	14
1.1. Analysis of prototypes and short description of designing aircraft .....	14
1.1.1. Choice of the projected data.....	14
1.1.2. Brief description of the main parts of the aircraft.....	17
2. GEOMETRY CALCULATIONS OF THE AIRPLANE MAIN PARTS.....	20
2.1. General geometry information .....	20
2.1.1. Wing geometry calculation .....	21
2.1.2. Fuselage layout.....	22
2.1.3. Baggage compartment.....	26
2.1.4. Galleys.....	27
2.1.5. Lavatories .....	27
2.1.6. Emergency exits .....	28
2.1.7. Layout and calculation of basic parameters of tail unit .....	29
2.1.8. Landing gear design .....	30
2.2. Center of gravity calculation.....	31
2.2.1 Trim-sheet of the equipped wing .....	32
2.2.2 Trim-sheet of the equipped fuselage masses .....	33
2.2.3 Calculation of center of gravity positioning variants.....	35
3. CONVERSION OF THE MEDIUM RANGE PASSENGER AIRCRAFT INTO MEDICAL VARIANT.....	39
3.1. History and overview of medical aircraft and evacuation .....	39
3.2. What must be done for the conversion.....	42
3.3. Analysis of necessary equipment.....	44
3.3.1. Technical characteristics of installed equipment .....	50
3.4. Center of gravity of medical aircraft.....	50
3.4.1. Trim-sheet of the equipped fuselage masses .....	51
3.4.2 Calculation of center of gravity positioning variants.....	53
Conclusion to part 3 .....	55
GENERAL CONCLUSIONS .....	56

					<b>NAU 23 06L 00 00 00 52 EN</b>			
	<i>Sh.</i>	<i>Nº doc.</i>	<i>Sign</i>	<i>Date</i>		<i>list</i>	<i>sheet</i>	<i>sheets</i>
<i>Checked by</i>		<i>Liashenko Y.</i>			<b>Content</b>		10	68
<i>St.control.</i>		<i>Zakiev V.I.</i>				<b>402 ASF 134</b>		
<i>Head of dep.</i>		<i>Krasnopolskyi V.S.</i>						
		<i>Ignatovich S.R.</i>						

REFERENCE'S .....	57
Appendix A .....	59
Appendix B.....	64
Appendix C.....	66
Appendix D .....	68

					<i>NAU 23 06L 00 00 00 52 EN</i>			
	<i>Sh.</i>	<i>Nº doc.</i>	<i>Sign</i>	<i>Date</i>				
		<i>Liashenko Y.</i>			<i>Content</i>	<i>list</i>	<i>sheet</i>	<i>sheets</i>
<i>Checked by</i>		<i>Zakiev V.I.</i>					11	68
<i>St.control.</i>		<i>Krasnopol'skiy V.S.</i>				<b>402 ASF 134</b>		
<i>Head of dep.</i>		<i>Ignatovich S.R.</i>						

## INTRODUCTION

Airplanes are the fastest and best way to travel around the globe and get to any part of the world. Air travel connects most of the world's countries and is a highly efficient option for transporting cargo and passengers. Also, traveling by air is the safest transportation in the world. Based on the Road Crash Statistics report, approximately 3,287 people lose their lives daily due to car accidents worldwide. This staggering number accumulates to around 1.3 million fatalities each year. It is worth noting the significant disparity when comparing these statistics to the data provided by Dutch experts on commercial air transportation. Their analysis reveals that out of every 16 million flights, merely a single air crash occurs. Due to these advantages of airplanes, the demand for this service is growing, and because of this, the need for aviation specialists and aircraft production is growing.

One of the stages of production is the preliminary design of an airplane, which will be described in this thesis. The purpose of my work is to develop a project of a medium-haul passenger aircraft for 110 passengers to show how many stages of design and calculations an airplane must go through to be put into service for safe flight and use; and to investigate the possibility and necessity of using the aircraft for medical evacuation.

A special part is devoted to the conversion of a passenger aircraft into a medical one. In today's world, where speed and efficiency play a central role in life-saving medical operations, medical aircraft conversion is becoming an ever more important initiative. This innovative technology allows for the rapid conversion of a conventional aircraft into a fully functional medical vehicle, providing emergency medical care in remote and challenging areas.

					<b>NAU 23 06L 00 00 00 52 EN</b>							
	<i>Sh.</i>	<i>Nº doc.</i>	<i>Sign</i>	<i>Date</i>	<b>Introduction</b>			<i>list</i>	<i>sheet</i>	<i>sheets</i>		
<i>Done by</i>	<i>Liashenko Y.A.</i>									12	68	
<i>Checked by</i>	<i>Zakiev V.I.</i>							<b>402 ASF 134</b>				
<i>St.control.</i>	<i>Krasnopol'skiy V.S.</i>											
<i>Head of dep.</i>	<i>Ignatovich S.R.</i>											

# 1. PRELIMINARY DESIGN OF MEDIUM RANGE AIRCRAFT

## 1.1. Analysis of prototypes and short description of designing aircraft

### 1.1.1. Choice of the projected data

The process of optimizing the structural parameters of an aircraft is both intricate and captivating, with the ultimate goal of creating an aircraft design that is exceptionally well suited. The selection of optimal parameters encompasses a range of considerations, including flight technical requirements, weight, geometry, aerodynamics, and economy.

During the initial phase of aircraft design, statistical methods play a crucial role. These methods provide approximate values for the parameters, which serve as a foundation for subsequent calculations.

Moving on to the second stage, a more comprehensive analysis takes place. This involves conducting thorough aerodynamic calculations, utilizing updated formulas to determine the mass of individual aircraft components, and even incorporating experimental data. These meticulous efforts yield precise results and ensure the aircraft's performance is optimizing.

In the end, a set of design parameters can be determined that fulfills all requirements, thus attaining the desired outcome.

In this diploma work, I chose the Boeing 737-600, which is a representative of middle-range aircraft, as the main prototype for the design of the aircraft. This aircraft has excellent technical characteristics [1].

It is also advisable to choose Boeing 737-200 and Airbus A320-200 as prototypes, which have some common characteristics.

All technical data of prototypes presented in Table 1.1.

The geometry characteristics (wingspan, fuselage length, diameter, cabin characteristics, tail unit etc.) [2] of prototypes presented in Table 1.2.

					<i>NAU 23 06L 00 00 00 52 EN</i>		
	<i>Sh.</i>	<i>Nº doc.</i>	<i>Sign</i>	<i>Date</i>			
<i>Done by</i>	<i>Liashenko Y.A.</i>				<i>list</i>	<i>sheet</i>	<i>sheets</i>
<i>Checked by</i>	<i>Zakiev V.I.</i>					14	68
<i>St.control.</i>	<i>Krasnopolskyi V.S.</i>				<i>Analytical part</i>		
<i>Head of dep.</i>	<i>Ignatovich S.R.</i>						

Table 1.1.

### Technical data of prototypes

Parameters	B737-200	B737-600	A320-200
The purpose of airplane	Passenger	Passenger	Passenger
Maximum take-off weight, $m_{tow}$ , kg	52390	65554	77000
Passenger's seat	136	149	179
Range $m_{k,max}$ , km	4260	5650	6150
Number and type of engines	2 turbofan engines	2 turbofan engines	2 turbofan engines
Bypass ratio	0.99	5.5	no data
Thrust to weight ratio, kN/kg	0.2771	0.2568	no data
Aerodrome code letter	4C	4C	4C
Landing mass, kg	46720	55112	64500
Empty weight, kg	27120	37104	37200
Payload fraction, %	0.2996	0.2193	0.2584
Takeoff distance, m	1830	1900	2190
Landing distance, m	1400	1300	1440

Boeing and Airbus aircraft recognize as the world's leading aviation brands, earning the trust and respect of passengers and airlines alike through their excellent technical performance and outstanding quality of operations. Boeing is known for its ability to operate long-haul routes and high passenger capacity, ensuring comfort and safety for hundreds of passengers. Airbus, meanwhile, is known for innovative technologies focused on fuel efficiency and reducing emissions. Both aircraft manufacturers continue to hold on to their reputation as reliable and advanced aircraft suppliers, which guarantee the safety and comfort of passengers around the world.

Table 1.2.

### Geometry characteristics

<b>Main geometric parameters</b>	<b>B737-200</b>	<b>B737-600</b>	<b>A320-200</b>
Wingspan, m	28.35	34.3	34.1
Quarter-chord sweep angle, °	25	25	25
Mean chord, m	3.80	4.17	4.29
Aspect ratio	8.83	9.45	9.39
Taper ratio	0.266	0.159	0.240
Fuselage length, m	29.84	29.88	37.57
Fuselage diameter, m	3.76	3.76	no data
Fuselage fineness ratio	7.92	8.01	9.51
The form of the cross-section fuselage	circular	circular	circular
HT span, m	12.7	13.4	12.45
Quarter-chord sweep angle of HT, °	30	30	29
HT aspect ratio	5.15	5.54	5
HT taper ratio	0.260	0.286	0.256
VT height, m	5.85	6	6.26
Quarter-chord sweep angle of VT, °	35	35	34
VT aspect ratio	1,74	1,56	1,82
Gear nacelles, m	25,1	25,6	25,1
Wheel track, m	5.23	5.70	7.60

### 1.1.2. Brief description of the main parts of the aircraft

The airplane I am designing is a narrow fuselage airplane, which means a diameter of up to 4 meters. Its structure consists of an all-metal semi-monocoque body and a low wing position. The aircraft is powered by 2 turbojet engines. It can carry up to 110 business and economy class passengers. It has a flight altitude of 11 kilometers and a maximum range with a maximum load of 5648 kilometers.

The airplane consist of the next parts:

- Low wing position;
- Power unit with 2 turbofan engines;
- Regular tail, mid set;
- Fuselage, with pressurized cabin for crewmembers, passengers and cargo placement.

This photo show general view of the main prototype, B737-600 (fig. 1.1.).

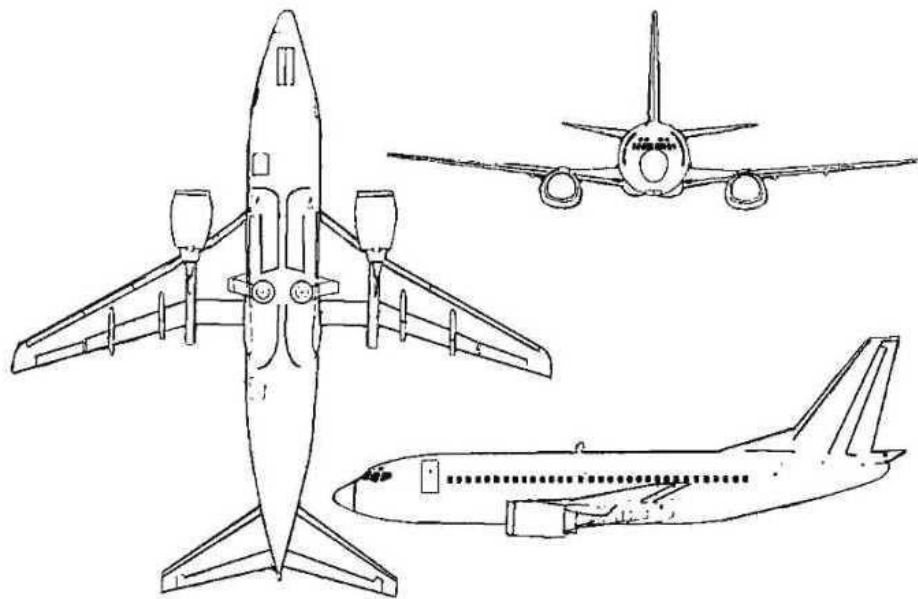

Fig. 1.1. General view

A key feature of this aircraft is its compact size, making it an excellent choice for smaller airports and regional routes. Its reduced length makes it easy to navigate on short runways, which are often found at small airports.

Another important aspect is its increased fuel efficiency. Equipped with state-of-the-art engines, it ensures optimal fuel consumption and minimizes environmental impact.

					<b>NAU 23 06L 00 00 00 52 EN</b>	Sheet
Ch	Sheet	Document №	Sign	Date		17



This aspect not only brings economic benefits to airlines, but also helps to reduce the environmental impact of the aircraft.

In addition, this liner demonstrates remarkable universality, effectively performing various missions, including both scheduled passenger transportation and charter or cargo flights. This flexibility helps airlines to maximize the efficiency of the aircraft in accordance with their specific requirements and market conditions.

This airplane features a low wing and winglets configuration that combines the power of two turbofan CFM56-7B20 engines. The high aspect ratio wing design with a sweptback shape improves the lift-to-drag ratio and results to excellent fuel economy.

The aircraft under development attracts attention with its caisson wing. The wing consists of a set of spars, nerves, thickened skin, and a strut set, which gives it stability and strength. Various devices such as leading edge slit, trailing edge flaps, ailerons, and spoilers are placed on this wing. These advanced devices have a positive effect on the take-off and landing characteristics of this aircraft. In addition, the ailerons and spoilers are located outside the wing skin, which contributes to their efficiency and affects the all performance of the aircraft. We choose the next parameters of the wing:  $\lambda_w=9.45$ ,  $\eta_w=3.50$ , sweep back angle is  $25^\circ$ . Picture show view of the wing (fig. 1.2.).



Fig. 1.2. How the wing of prototype looks like

The fuselage, which is the largest part of the aircraft, is a unique round semi-monocoque structure. Inside the fuselage are the cockpit, passenger section, and service areas. The technical compartments, niches for landing gear supports and the central power plant compartment are located under the floor. An important feature of the fuselage is its complete hermeticity. In the center of the fuselage are the wing struts and main landing gear mounts, which performs an important function of joining all the components of the aircraft. The rear power compartment reserve for wing attachment. The floor of the passenger compartment consists of a frame, including cross beams and removable floor panels, and has a hatch for access to the underground space, which increases the functionality of this important element of the aircraft. We choose the next parameters of the fuselage: diameter = 4.01m.

Aircraft landing gear is one of the major systems that ensures proper landing and movement of the plane on the runway surface. Its main purpose is to support the aircraft on the ground, as well as to ensure safety and stability while moving along the runway and airfield.

The landing gear consists of a variety of components, including struts, wheels, and shock absorption systems. It is located under the fuselage of the aircraft and can be retractable or permanent. The retractable undercarriage can be raised and lowered to facilitate takeoff and landing, and is in a protected position during flight.

The landing gear distributes the weight of the aircraft to several support points, which reduces the load on each of them. In addition, the landing gear has shock absorption systems that absorb shocks and vibrations during landing.

## Conclusions to the analytical part

The analysis of airplane prototypes, in particular the main B737-600 prototype, is of great importance for a successfully completed preliminary design of an airplane. Exploring the main characteristics of this prototype, such as its size, weight, payload, range, and airspeed, offers us a highly valuable data set that influences all aspects of our own plane design.

The data collections from the A320-200 and B737-200 prototypes expand the understanding of the technical characteristics and allow us to better familiarize ourselves with the aircraft modifications to develop our own design.

The accumulated information from prototype aircraft is a valuable asset that helps us incorporate best practices and innovations implemented in existing models. It contributes to the quality, reliability and competitiveness of our own aircraft. This approach allows us to effectively combine the knowledge we have gained with innovative solutions to create an unrivaled product.

By balancing advanced engineering with learnings from prototype analysis, we are providing the basis for a new era of air travel. Our desire to implement the best practices and achievements demonstrated by these prototypes ensures that our planes will be at the forefront of progress, setting new standards in the industry.

					<i>NAU 23 06L 00 00 00 52 EN</i>	Sheet
<i>Ch</i>	<i>Sheet</i>	<i>Document №</i>	<i>Sign</i>	<i>Date</i>		20

## 2. GEOMETRY CALCULATIONS OF THE AIRPLANE MAIN PARTS

### 2.1. General geometry information

Every component of an airplane is important to its overall performance, and the geometry of these parts is carefully taken into account during their design and manufacture.

When designing wings, engineers study a variety of geometric parameters, such as profile shape, span-to-width ratio, camber angle, and wing distance. These calculations are important because they have a direct impact on the aerodynamic properties of the aircraft, such as lift and drag [3].

The tail fin geometry is very important. The dimensions and control angles of the rudder are critical to the stability and controllability of the aircraft. Careful attention to these geometric aspects helps to ensure proper balance and manoeuvrability of the aircraft.

The fuselage, the main body of the airplane, is also subject to geometric calculations. The size, shape, and volume of the fuselage affects the aerodynamics, cargo capacity, and safety of passengers. By optimizing the fuselage geometry, engineers try to increase the overall efficiency and function of the aircraft [4].

Vertical and horizontal stabilizers, which are responsible for the stability of the plane, also have their own geometric specifications. The dimensions, profile shape, and pitch angles taken into account to determine their impact on the stability and controllability of the aircraft.

To perform geometric calculations, specialized computer programs and engineering methods are used. With the help of these methods, engineers ensure optimal aerodynamics, stability and structural strength of the vehicle. This careful work with geometry is critical to the safety and efficiency of aircraft in various flight conditions.

					<i>NAU 23 06L 00 00 00 52 EN</i>			
	<i>Sh.</i>	<i>Nº doc.</i>	<i>Sign</i>	<i>Date</i>				
<i>Done by</i>	<i>Liashenko Y.A</i>				<i>Project part</i>	<i>list</i>	<i>sheet</i>	<i>sheets</i>
<i>Checked by</i>	<i>Zakiev V.I.</i>						20	65
<i>St.control.</i>	<i>Krasnopol'skiy V.S.</i>					<i>402 ASF 134</i>		
<i>Head of dep.</i>	<i>Ignatovich S.R.</i>							

### 2.1.1. Wing geometry calculation

These calculations are basing on the wing loading and gross weight specified in the initial data (Appendix A). So let calculate the  $S_{wing}$ , area of the wing;

$$S_{wing} = \frac{m_0 \cdot g}{P_o} = \frac{60707 \cdot 9.8}{4493} = 132 \text{ m}^2$$

where  $S_{wing}$  – wing area,  $m^2$ ;  $g$  – acceleration due to gravity  $m/s^2$ ;  $P_o$  – wing loading at cruise regime of flight;  $m_0$  – take off mass of the aircraft.

The wingspan is determine by the formula:

$$l = \sqrt{S_{wing} \cdot \lambda_w} = \sqrt{132 \cdot 9.45} = 35 \text{ m},$$

where  $l$  – wing span, m;  $\lambda_w$  – aspect ratio.

Root chord is:

$$b_t = \frac{C_{root}}{\eta_w} = \frac{5.9}{3.50} = 1.685 \text{ m},$$

where  $b_o$  – root chord, m;  $\eta_w$  – wing taper ratio.

Tip chord is:

$$b_0 = \frac{2S_w \cdot \eta_w}{(1 + \eta_w) \cdot l} = \frac{2 \cdot 132 \cdot 3.50}{(1 + 3.50) \cdot 35} = 5.9 \text{ m},$$

where  $b_t$  – tip chord, m.

Maximum wing thickness is determined in forehead i-section and is:

$$c_i = c_w \cdot b_t = 0.12 \cdot 1.685 = 0.2022 \text{ m},$$

where  $c_w$  – related wing thickness.

Board chord for trapezoidal shaped wing is:

$$b_b = b_o \cdot \left(1 - \frac{(\eta_w - 1) \cdot D_f}{\eta_w \cdot l_w}\right) = 5.9 \cdot \left(1 - \frac{(3.50 - 1) \cdot 4.01}{3.50 \cdot 35}\right) = 5.417 \text{ m},$$

where  $b_b$  – wing board chord, m;  $D_f$  – fuselage diameter, m.

Double or triple spar wings are commonly utilizing in modern aircraft for enhanced structural integrity. In the case of the specific aircraft design, it incorporates a dual spar configuration.

We could calculate the MAC by the formula:

For trapezoidal wing shape:

					<b>NAU 23 06L 00 00 00 52 EN</b>	Sheet
Ch	Sheet	Document №	Sign	Date		21

$$b_{MAC} = \frac{2}{3} \frac{b_o^2 + b_o b_t + b_t^2}{b_o + b_t} = \frac{2}{3} \cdot \frac{5.9^2 + 5.9 \cdot 1.685 + 1.685^2}{5.9 + 1.685} = 4.1828$$

Having reached the final stage of measuring the geometric characteristics of the wing, our focus now shifts towards evaluating the geometry of the ailerons and high-lift devices. This crucial step allows us to analyze and optimize the specific design features of these components, ensuring their effectiveness in enhancing control and lift capabilities during various flight conditions.

The determination of the geometric parameters of the aileron follows a systematic approach:

- Aileron span:

$$l_{ail} = \frac{(0.3...0.4)l_w}{2} = 0.35 \cdot \frac{35}{2} = 6.1 \text{ m.}$$

- Aileron area:

$$s_{ail} = \frac{(0.05...0.08)S_w}{2} = 0.06 \cdot \frac{132}{2} = 3.96 \text{ m}^2..$$

### 2.1.2. Fuselage layout

The main characteristics of an airplane fuselage include length, width, and height, which play an important role in defining its geometric characteristics. It is also necessary to perform detailed calculations of the fuselage volume, as this affects the overall weight distribution [5].

The correct volume distribution ensures the balance and stability of the aircraft during the flight.

The configuration of the fuselage also requires careful placement of various systems and components, such as passenger seats, undercarriage, and avionics. The placement of these items within the fuselage is important for weight distribution, center of gravity, and easy access for maintenance and repair.

The International Civil Aviation Organization (ICAO) is one of the organizations that sets out international standards and guidelines for aircraft cabin layout. Documents such as the Standards for the Organization and Design of the Passenger Cabin (Doc 9705) and Passive Safety Recommendations for Passenger Cabin Layout (Doc 10082) developed by ICA define the requirements for safety,

					<b>NAU 23 06L 00 00 00 52 EN</b>	Sheet
Ch	Sheet	Document №	Sign	Date		22

efficiency, and comfort in civil aviation. The application of these standards helps to ensure optimal cabin layout, meeting the needs of passengers and the requirements of international safety standards.

Next, we will calculate the basic geometric features of the fuselage and create a passenger compartment layout that takes into account the number of seats.

Length of the aircraft fuselage:

$$L_{fus} = FR \cdot D_f = 7.95 \cdot 4.01 = 31.87 \text{ m,}$$

where  $FR$  – fineness ratio,  $D_f$  – diameter of fuselage.

Length of aircraft fuselage forward part:

$$L_{fwd} = FR_{fwd} \cdot D_f = 1.6 \cdot 4.01 = 6.4 \text{ m,}$$

where  $FR$  – fineness ratio of forward part.

Length of the fuselage tail part:

$$L_{tail} = FR_{tail} \cdot D_f = 3.1 \cdot 4.01 = 12.4 \text{ m,}$$

where  $FR$  – fineness ratio of tail part.

To calculate the cabin width of a passenger aircraft in the area where passenger seats are situated, a specific formula is employed. This formula takes into account various factors such as the overall dimensions of the cabin, the number of seats per row, and any additional considerations related to passenger comfort and accessibility. By applying this formula, engineers can accurately determine the cabin width, ensuring an optimal arrangement of seats and a comfortable environment for passengers during their journey.

The width of the cabin for an economy class aircraft, where passenger seats arranged in a 3+3 row configuration, is carefully determined during the design process. This takes into account the size of each chair, the space required for armrests, the width of the aisle and other factors that affect passenger comfort and safety. This photo show variant of designing of economy class (fig. 2.1.).



Fig. 2.1. Economy class

Following industry standards and regulations ensure that the cabin width provides sufficient space for passengers in economy class. This ensures comfortable seating, adequate shoulder and elbow space, and easy access to the aisle for moving around the cabin.

$$B_{cab} = n_3 b_3 + n_{aisle} b_{aisle} + 2\delta + 2\delta_{wall}$$

$$B_{cab} = 2 \cdot 1450 + 1 \cdot 460 + 2 \cdot 50 + 2 \cdot 100 = 3660 \text{ mm,}$$

where  $n_3$  – number of blocks of seats;  $b_3$  – width of block of seats, mm;  $n_{aisle}$  – number of aisles;  $b_{aisle}$  – aisle width, mm;  $\delta$  – distance between external armrests to the decorative panels, mm;  $\delta_{wall} = 80 - 120$  – width of the wall, mm.

In the business class cabin, the passenger seats designed with a configuration of 2 seats on one side and 2 seats on the other side in each row. This photo show variant of configuration of business class (fig. 2.2.).





Fig. 2.2. Business class

This layout is commonly known as a "2 + 2" arrangement. Let us calculate:

$$B_{cab} = n_2 b_2 + n_{aisle} b_{aisle} + 2\delta + 2\delta_{wall};$$

$$B_{cab} = 2 \cdot 1340 + 1 \cdot 600 + 2 \cdot 90 + 2 \cdot 100 = 3660 \text{ mm.}$$

Upon determining the cabin width, it is essential to also define the cabin height, as it plays a crucial role in ensuring passenger comfort. This dimension greatly contributes to the overall space and atmosphere inside the aircraft.

For narrow-body planes with fewer than six seats in a single row, careful consideration is given to determining the appropriate cabin height. The objective is to provide sufficient headroom and a comfortable environment for passengers.

$$H_{cab} = 1.48 + 0.17 B_{cab};$$

$$H_{cab} = 1.48 + 0.17 \cdot 3.76 = 2.12 \text{ m.}$$

A passenger seat is an important component for a comfortable flight. Providing an appropriate seat pitch that meets the needs of the flight duration and cabin class.

Seat pitch, or the distance between a point on one seat and the same point on the seat in front or behind, plays a very important role in passenger comfort during a flight.

It is also important to note that seat recline is typically measured in inches and should be a multiple of one inch (25.4 mm).

This standardization ensures consistency and ease of measurement when installing seats.

By following this requirement, airlines can efficiently control and allocate cabin space, maximizing passenger comfort while maintaining efficient use of existing space.

The length of economic passenger cabin:

$$L_{econ} = L_1 + (N - 1)L_{seatpitch} + L_2,$$

$$L_{econ} = 1200 + (15 - 1) \cdot 760 + 300 = 12140 \text{ mm},$$

where  $L_{seatpitch}$  – length of seat pitch

The length of business passenger cabin is equal:

$$L_{bus} = L_1 + (N - 1)L_{seatpitch} + L_2$$

$$L_{bus} = 1200 + (5 - 1) \cdot 960 + 300 = 5340 \text{ mm},$$

The windows placed in a single row on both sides of the fuselage to provide passengers with a view of the outside world. They have a rectangular shape with rounded corners. The choice to use rounded corners made to reduce the concentration of stress near the window zone.

### 2.1.3. Baggage compartment

The baggage compartment, also known as the cargo hold or baggage compartment is a special room for the safe storage of passenger baggage, cargo and various items during air travel. Located below the passenger compartment, in the bottom part of the aircraft fuselage, this section is carefully design to accommodate a significant amount of baggage and cargo, and its capacity may change depending on the size and capabilities of the aircraft.

The area of cargo compartment is define:

$$S_{cargo} = \frac{M_{bag}}{0.4K} + \frac{M_{cargomail}}{0.6K};$$

$$S_{cargo} = \frac{20 \cdot 110}{0.4 \cdot 600} + \frac{15 \cdot 110}{0.6 \cdot 600} = 13.75 \text{ m}^2,$$

Where  $M_{bag}$  – mass of baggage's of all passengers,  $M_{cargomail}$  – mass of additional cargo and mails on the board of aircraft, near 15 kilograms for each passenger.

					<b>NAU 23 06L 00 00 00 52 EN</b>	Sheet
Ch	Sheet	Document №	Sign	Date		26

Cargo compartment volume is equal:

$$V_{cargo} = v \cdot n_{pass} = 0.2 \cdot 110 = 22 \text{ m}^3,$$

where  $n_{pass}$  – number of passengers.

### 2.1.4. Galleys

According to standards, when an aircraft has a mixed layout, it is mandatory to have two separate galley. This allows for compliance with regulatory requirements and gives the aircraft adequate capacity to serve passengers in every part of the airplane.

Kitchen cupboards in an aircraft must be position near the entrance area, ideally between the cockpit and the passengers or cargo compartments.

To adhere to recommended standards, the volume of galleys in an aircraft should approximate around 0.1 cubic meters per passenger:

$$V_{galley} = 0.1 \cdot n_{passenger} = 0.1 \cdot 110 = 11 \text{ m}^3$$

The total area of galley floor:

$$S_{galley} = \frac{V_{galley}}{H_{cab}} = \frac{11}{2.12} = 5.18 \text{ m}^2.$$

### 2.1.5. Lavatories

Considering the specifications of the aircraft, the selected configuration calls for two lavatories. This choice aligns with the original design and ensures an appropriate number of restroom facilities for passengers on board.

The number of lavatories to be install on an aircraft based on the number of passengers and the flight time. For flights longer than 4 hours, it advised to have one toilet for every 40 passengers. For trips lasting from 2 to 4 hours, the recommended ratio is one toilet for every 50 passengers. For flights with a duration of under 2 hours, it recommended to have one toilet for each 60 passengers.

This proportion guarantees a sufficient number of toilets to satisfy the needs of passengers for various flight durations. Area of lavatory:  $S_{lav} = 1.5 \text{ m}^2$ . This photo show example of design of lavatory (fig. 2.3.).

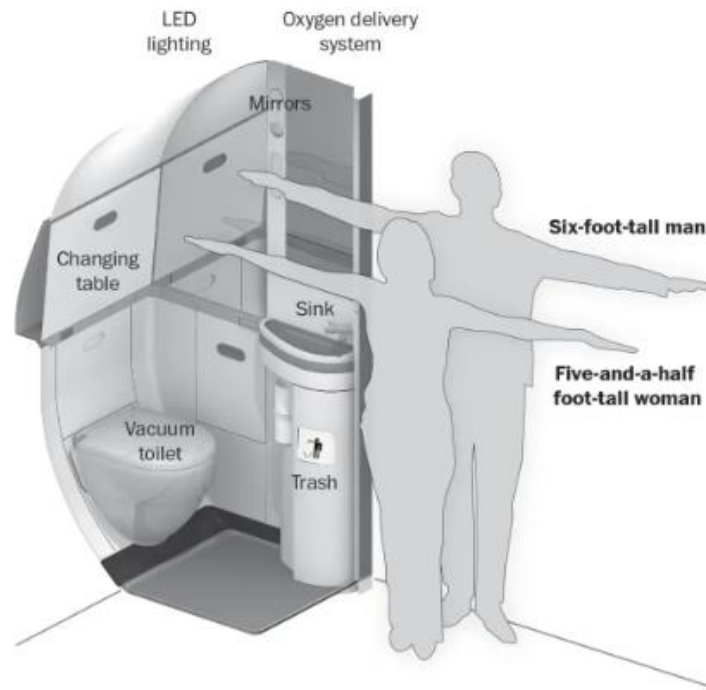

Fig. 2.3. Design of lavatory and comparing with height of human

The width of each lavatory on the aircraft is set at 1 meter. As per the aircraft design, two galleys and two lavatories incorporated into the layout.

### 2.1.6. Emergency exits

Emergency exits in narrow-body aircraft are strategically located to facilitate the quick and safe evacuation of passengers in case of emergency. These exits are usually located above the wings, in the front and rear of the aircraft, and near the tail section. They have large doors that open outward or slide upward, providing unobstructed escape routes. Clear signage, illuminated exit signs and floor markings direct passengers to the nearest exits [6]. Emergency ladders or rafts deployed to assist in evacuation, allowing passengers to leave the aircraft quickly.

Passengers informed about the location and operation of emergency exits during safety briefings, emphasizing the importance of following crew instructions.

In narrow-body aircraft, all doors are designing to serve as emergency exits.

If the exits on narrow-body aircraft are placed at a considerable height above the ground, it is necessary to provide passengers with an inflatable emergency ladder for safe evacuation. The total weight of such a ladder is about 45 kilograms and is located by the emergency hatch.

For the complete safety of passengers in the most unpredictable situations, the aircraft is equipped with inflatable vests and life rafts. This will save lives in case of an emergency landing on water.

### 2.1.7. Layout and calculation of basic parameters of tail unit

The design of the tail unit (TU) for an aircraft is a very important stage of the design process, as it has a direct impact on its stability and controllability. The main function of the horizontal fin is to provide longitudinal stability and pitch control during flight.

Determination of the TU geometrical parameters:

$$S_{HTU} = (0.18 \dots 0.25) \cdot S = 0.2 \cdot 132 = 26.4 \text{ m}^2,$$

$$S_{VTU} = (0.12 \dots 0.20) \cdot S = 0.15 \cdot 132 = 19.8 \text{ m}^2.$$

Where  $S$  – area of wing.

Determination of the elevator area and direction:

$$S_{el} = (0.3 \dots 0.4) S_{HTU} = 0.3 \cdot 26.4 = 7.92 \text{ m}^2,$$

$$S_{rudder} = (0.2 \dots 0.22) S_{VTU} = 0.2 \cdot 19.8 = 3.96 \text{ m}^2.$$

Area of elevator trim tab:

$$S_{te} = (0.08 \dots 0.12) S_{el} = 0.1 \cdot 7.92 = 0.792 \text{ m}^2.$$

Area of rudder trim tab:

$$S_{tr} = (0.04 \dots 0.06) S_r = 0.05 \cdot 3.96 = 0.198 \text{ m}^2.$$

The span of the horizontal tail unit determined by the following relationship:

$$l_{HT} = (0.32 \dots 0.5) l_w = 0.35 \cdot 35 = 12.25 \text{ m}.$$

					<b>NAU 23 06L 00 00 00 52 EN</b>	Sheet
Ch	Sheet	Document №	Sign	Date		29

Determination of tail  $b_{tip}$ ,  $b_{cax}$ ,  $b_{root}$ :

$$b_{tip} = \frac{2S_{htu}}{(\eta_{htu} + 1)l_{htu}} = \frac{2 \cdot 26,4}{(3 + 1) \cdot 8,36} = 1,578,$$

where  $L_{HTU} = (2.0 - 2.3) b_{mac}$ , for planes  $M < 1$   $\eta_{htu} = 2 - 3$ ,  $\eta_{vtu} = 1 - 1,33$ .

$$b_{cax} = 0,66 \frac{\eta_{htu}^2 + \eta_{htu} + 1}{\eta_{htu} + 1} \cdot b_{htu\ tip} = 0,66 \frac{3^2 + 3 + 1}{3 + 1} \cdot 1,578 = 3,384.$$

$$b_{root} = b_{tip} \cdot \eta_{htu} = 1,578 \cdot 3 = 4,734.$$

To ensure control during wing shock stall, the sweptback angle of the horizontal tail unit selected within the range of 3 to 5 degrees, which is not bigger than the wing sweptback angle. In this case, we choose a sweptback angle of 5 degrees to effectively maintain aircraft control during such critical flight conditions.

### 2.1.8. Landing gear design

Landing gear (LG) configuration consists of two or more main undercarriage units located in the wings or fuselage, along with an auxiliary undercarriage unit at the nose or tail [7].

The landing gear performs crucial functions, such as providing support during ground maneuvers, dampening vibrations, and absorbing the impact of landings. However, based on the available initial data, the current calculation stage allows for the determination of only certain parameters of the landing gear [8].

The distance from the center of gravity to the main LG:

$$B_m = (0,15 \dots 0,20) b_{MAC} = 0,2 \cdot 4,1828 = 0,086$$

Landing gear wheelbase calculate:

$$B = (0,3 \dots 0,4) l_f = (6 \dots 10) B_m = 8 \cdot 0,0836 = 6,68$$

The distance from the center of gravity to the nose LG:

$$B_n = B - B_m = 6,68 - 0,0836 = 6,5964$$

Wheel loads are determined by:

- main support wheel:

$$P_{main} = \frac{9.81(B - e)m_o}{B \cdot n \cdot z} = 131276.38(N) = 29512lbf$$

- front support wheel:

$$P_{support} = \frac{9.81 \cdot C_{d-e}m_o}{B \cdot n \cdot z} = 52822(N) = 11874lbf$$

According to the calculated value of the load on the wheels choose the following wheel parameters: for main - Aircraft Rib 34.5x9.75-18 461B-3268-TL; for support - Flight Eagle 26x6.75-14 265K68-2.

## 2.2. Center of gravity calculation

The center of gravity is the point at which an aircraft would be in a state of equilibrium, if it could suspend from that point. The longitudinal balance is critically important - it is the placement of the CG on the longitudinal or lengthwise axis.

Calculating the center of gravity is an important procedure to ensure the safe flight of an aircraft. This process involves determining the weight and the arm of each element on board the aircraft, and then calculating the moment by multiplying the weight by the arm. The summation of all the moments gives us the total moment.

To ensure safety and optimal controllability of the aircraft, manufacturers set limits on the center of gravity within which the aircraft must stay during flight. Keeping within these limits is critical to the stability and efficiency of the aircraft during the various phases of flight [9]. The calculations use a constant reference point known as datum, which determined by the manufacturer. The arm calculated as the distance from the datum to each element. Example is giving in photo (fig. 2.4.). Modern aircraft more and more often use automated systems to calculate the center of gravity. The pilots and maintenance team still check these calculations, however, and make sure that the center of gravity is within safe limits for the particular plane.

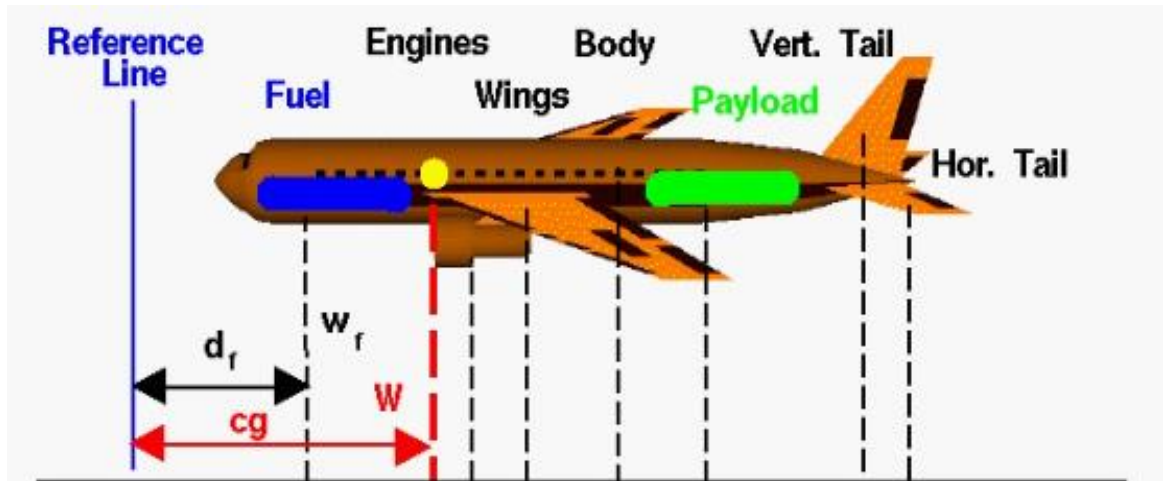

Fig. 2.4. Aircraft center of gravity

### 2.2.1 Trim-sheet of the equipped wing

The weight of an equipped wing comprises the weight of its structural components, a portion of the equipment's weight, the landing gear, and the fuel load.

This formula define the coordinates of the center of power for the equipped wing:

$$x'_w = \frac{\sum m'_i x'_i}{\sum m'_i} = \frac{48204.23}{37440.98} = 1.28 \text{ m,}$$

where  $\sum m'_i x'_i$  - total moment of mass of wing,  $\sum m'_i$  - total mass.

Table 2.1.

Trim sheet of equipped wing

№	Object name	Mass		C.G coordinates Xi, M	Moment of mass
		Units	Total mass m(i)		
1	Wing	0.11125	6753.65	1.79826	12144.82
2	Fuel system	0.0093	564.57	1.77735	1003.44
3	Flight control system, 30%	0.038469	2335.33	2.5092	5859.82



Continue Table 2.1.

№	Object name	Mass		C.G coordinates Xi, m	Moment of mass
		Units	Total mass m(i)		
4	Electrical equipment, 10%	0.00331	200.94017	0.4182	84.03
5	Anti-ice system , 50%	0.01075	652.60	0.4182	272.91
6	Hydraulic systems, 70%	0.01225	743.66	2.5092	1865.99
7	Engines	0.09333	5665.78	-1.6	-9065.25
8	Nose landing gear, 10%	0.003036	184.30	-4.58	-844.12
10	Fuel	0.31785	19295.71	1.79826	34698.72
	Total	0.616749	37440.98	1.287472557	48204.23

### 2.2.2 Trim-sheet of the equipped fuselage masses

The trim sheet of an equipped fuselage is an integral part of the process of determining the weight and balance of an aircraft. It provides detailed knowledge of the mass distribution within the fuselage, which is essential to ensure safe and stable flight.

The trim sheet shows the various masses that affect the airframe. This includes the mass of the structures that form the body of the vehicle, the avionics systems that support navigation and communication, the interior, which contains the seats and cockpit for passengers, and the equipment installed inside the fuselage.

A moment calculated for each mass. This gives an idea of the force generated by each mass given its position inside the fuselage. Add these moments together to get a total moment that reflects the distribution of the masses inside the fuselage.

Table 2.2.

## Trim sheet of equipped fuselage

№	Objects names	Mass		C.G coordinates Xi, M	Moment of mass
		Units	Total mass		
1	Fuselage	0.09403	5708.27	15.935	90961.42
2	Horizontal tail	0.00998	605.85	13.38	8106.35
3	Vertical tail	0.00985	597.96	3,34	1997.19
4	Navigation	0.0049	297.46	2	594.92
5	Radar	0.0033	200.33	1	200.33
6	Radio	0.0025	151.76	1	151.76
7	Instrument panel	0.0058	352.10	2	704.20
8	Flight control 70%	0.00455	276.21	15.935	4401.51
9	hydraulic system 30%	0.00525	318.71	22.309	7110.14
10	Anti-ice system, 25%	0.005375	326.30	25.496	8319.34
	Air-conditioning system, 25%	0.005375	326.30	15.935	5199.59
11	Electrical equipment, 90%	0.02979	1808.46	15.935	28817.83
12	Lining and insulation	0.0085	516.009	16.925	8733.46
13	Not typical equipment	0.004	242.82	3	728.48
14	Additional equipment	0.00401	243.43	5	1217.17
15	Operational items	0.002194	133.19	26	3462.97
16	Lavatory1, galley1 20%	0.00385	233.72	2.96	691.81
	Lavatory2, galley 2 20%	0.00385	233.72	27	6310.49
17	Passenger seats (economy class)	0.002965062	600	20	12000
18	Passenger seats (business class)	0.009883539	180	5.925	1066.5
	Seats of flight attendances	0.000329451	20	1.82	36.4
	Seats of pilots	0.000658903	40	1.48	59.2
	On board meal	0.002717973	165	22	3630
20	Baggage, cargo, mail	0.02536775	1540	18	33660
	Passengers	0.12683875	7700	20	154000
	Crew	0.007412654	450	2.4	1080
	TOTAL	0.38327808	23267.66		

The formula used to calculate the coordinates of the center of mass for the equipped fuselage provides the precise location information:

$$x'_w = \frac{\sum m'_i x'_i}{\sum m'_i} = \frac{377301.14}{23267.66} = 16.21 \text{ m,}$$

where  $\sum m'_i x'_i$  - total moment of mass of fuselage,  $\sum m'_i$  - total mass.

This formula allows us to ascertain the position of the wing's leading edge MAC in relation to the fuselage's nose. This achieved by calculating the value of  $x_{MAC}$  using the given equation:

$$X_{MAC} = \frac{m_f x_f + m_w x_w - m_0 C}{m_0 - m_w};$$

For low wing position:

$$C = (0.22 \dots 0.25) b_{MAC} = 1.003$$

$$X_{MAC} = \frac{23469.66 \cdot 16.31 + 37440 \cdot 1.28 - 60707 \cdot 1.003}{60707 - 37440} = 15.65$$

where  $m_0$  – aircraft takeoff mass, kg;  $m_f$  – mass of equipped fuselage, kg;  $x_f$  – coordination of fully equipped fuselage,  $m_w$  – mass of equipped wing, kg;  $x_w$  – coordination of equipped wing;  $C$  – distance from MAC leading edge to the C.G. point.

$$x_T = X_{MAC} + C;$$

$$x_T = 15.65 + 1.003 = 16.65;$$

$$x_T = \frac{C}{b_{MAC}} 100\%;$$

$$x_T = \frac{1.003}{4.182} \cdot 100\% = 23\%.$$

### 2.2.3 Calculation of center of gravity positioning variants

					<b>NAU 23 06L 00 00 00 52 EN</b>	Sheet
Ch	Sheet	Document №	Sign	Date		35

Table 2.3.

**Calculation of C.G. positioning variants**

<b>Name object</b>	<b>Mass, Kg m<sub>i</sub></b>	<b>Coordinate C.G., M</b>	<b>Mass moment Kg.m</b>
Equipped wing	16916.55	16.28	279498.61
Nose landing gear (extended)	184.31	10.98	2023.68
Main landing gear (extended)	1044.403	17.65	18433.72
Fuel reserve	2310.51	17.36	40108.09
Fuel for flight	16985.21	17.36	294846.10
Equipped fuselage (without payload)	13404.66	14.23	190871.14
Passengers	7700	20.00	154000.00
On board meal	165	22.00	3630.00
Cargo, mail	1540	18.00	27720.00
Crew	450	2.40	1080.00
Nose landing gear (retracted)	184.306452	10.98	2023.68
Main landing gear (retracted)	1044.403228	17.65	18433.72

Table 2.4.

**Airplanes C.G. position variants**

<b>№</b>	<b>Variants of the loading</b>	<b>Mass, kg</b>	<b>Moment of the mass, kg*m</b>	<b>Center of mass, m</b>
1	Take off mass (L.G. extended)	60708.64	1008114.35	16.61
2	Take off mass (L.G. retracted)	60708.64	1008112.41	16.61
3	Landing weight (L.G. extended)	43723.43	673160.16	15.4
4	Ferry version	52348.05	822762.41	15.7
5	Parking version	33868.43	509447.13	15.04

## Conclusion to the project part

In accordance with the recommendations and methodological materials of the National Aviation University, the Department of Aircraft Design, a section of geometric calculations of the aircraft have been performed.

Geometric calculations performed to determine the exact size and shape of our airplane, its wing and tail section. The centering process allowed achieving optimal weight centering and flight safety. The passenger cabin design accounted for the needs and specifications of passengers in varying classes of service. This process helped to optimize the use of space and create a comfortable environment for occupants and crew.

The calculations and numeral determinations performed accurately, which makes it possible to say that the preliminary design stage of the plane was successful. These results are a step in the implementation of our project and form the basis for the next stages of development and improvement of the aircraft.

The preliminary design process considers all of a number of factors that play an important role in the development of highly efficient, reliable, comfortable and environmentally sustainable aircraft. The results of this development stage define the further actions in the manufacturing, evaluation and implementation of the new aircraft in the aviation production.

					<i>NAU 23 06L 00 00 00 52 EN</i>	Sheet
<i>Ch</i>	<i>Sheet</i>	<i>Document №</i>	<i>Sign</i>	<i>Date</i>		38

### 3. CONVERSION OF THE MEDIUM RANGE PASSENGER AIRCRAFT INTO MEDICAL VARIANT

#### 3.1. History and overview of medical aircraft and evacuation

Medical care is an important component for ensuring the long-term and safe existence of a person. In the modern world, it is necessary to provide effective medical care in various situations, in emergency events, accidents, disasters, in general, in the event of a threat to human life and health. In these cases, quick and uninterrupted access to medical equipment and medics can save lives.

The last decade in Ukraine complied with by a trend towards an increase in the need for emergency medical care. This includes the COVID-19 pandemic, which has affected record numbers of people; a full-scale invasion by Russia and war days on the territory of Ukraine, which led to a great need for doctors and the immediate evacuation of victims to places of medical referral. According to the BBC (British Broadcasting Corporation), photo shows the number of deaths per week as of June 2022 (fig. 3.1.).

#### More than 10,000 deaths reported in Ukraine

Figure likely an underestimate due to difficulty in recording deaths in a war zone



Fig. 3.1. Military and civilian deaths by Russo-Ukrainian War

<i>NAU 23 06L 00 00 00 52 EN</i>										
	<i>Sh.</i>	<i>Nº doc.</i>	<i>Sign</i>	<i>Date</i>						
<i>Done by</i>	<i>Liashenko Y.A.</i>									
<i>Checked by</i>	<i>Zakiev V.I.</i>									
<i>St.control.</i>	<i>Krasnopolskyi V.S.</i>									
<i>Head of dep.</i>	<i>Ignatovich S.R.</i>									
<b>Special part</b>				<table border="1"> <tr> <td><i>list</i></td> <td><i>sheet</i></td> <td><i>sheets</i></td> </tr> <tr> <td></td> <td>39</td> <td>68</td> </tr> </table>	<i>list</i>	<i>sheet</i>	<i>sheets</i>		39	68
<i>list</i>	<i>sheet</i>	<i>sheets</i>								
	39	68								
				<b>402 ASF 134</b>						

Considering this, the conversion of a passenger plane into a medical plane becomes an important and necessary process. When it is possible to save many lives and ensure the necessary evacuation and transportation of a seriously ill or seriously injured person.

The first steps in organizing medical evacuation are associated with the actions of the French army during the First World War. Using small airplanes with medical equipment, doctors flew to the front lines and evacuated wounded soldiers to nearby medical facilities. This process was difficult due to the lack of high standards and organization.

Significant progress in the development of MEDEVAC (Medical evacuation by air) occurred during World War II. Special units equipped with medical airplanes and helicopters were create to ensure rapid evacuation from the battlefield. Various methods of transportation are using, including mixed aircraft that served as both trucks and ambulances.

After World War II, MEDEVAC continued development. New technologies and medical equipment introduced that improved the quality of medical care during evacuation. Military conflicts, such as the Korean War and others, provided new challenges and knowledge for effective evacuation, shows by picture (fig. 3.2.).



Fig. 3.2. Medical evacuation mission, Balad Air Base, Iraq



The experience gained over the years has significantly improved the effectiveness of medical care during flights and reduced the risk of adverse effects associated with the transportation of such patients.

To ensure the safety and comfort of patients during air evacuations, a special system has developed to engage highly qualified flight attendants and medical technicians who monitor the patients' condition throughout the flight. Their main goal is to minimize the discomfort and negative consequences that may arise because of an aircraft evacuation.

Ensuring the well-being of victims during an evacuation hinges on the crucial principle of MEDEVAC prioritization. This principle forms the bedrock of providing timely and appropriate care to those in need. Making informed decisions about which casualties to evacuate first and determining the most suitable medical facility for each individual is paramount in guaranteeing the highest standards of MEDEVAC [10].

Every choice made about prioritization holds significant sway over the overall success and efficiency of the evacuation process. Consequently, it is imperative for medical commanders to entrust these decisions to the most qualified professionals in the field, recognizing that expertise may extend beyond the realm of traditional medical practitioners.

These decisions should rest in the hands of individuals who possess the necessary skills, experience, and understanding to navigate the complexities of prioritization and its multifaceted implications. By prioritizing expertise and ensuring that the best-suited individuals tasked with these critical decisions, the potential for optimal care and successful MEDEVAC operations is maximizing.

In this part, we will look at the conversion of a medium-haul aircraft, the Boeing 737-600, as my prototype, into a medical aircraft. I chose for myself the option for transporting seriously ill and seriously injured military and civilian personnel, since my design does not provide for the installation of isolation modules for patients with severe respiratory diseases, including COVID-19.

The planning of the interior space of a medical aircraft must be carefully consider. It should contain space for equipment, medical tools, a first-aid kit and other necessary materials.

The location of seats for medical personnel should be optimal, providing adequate access to patients and maximum comfort during medical procedures.

Safety factors must also be taken into account when designing a medical aircraft. The aircraft must be equipped with systems that ensure flight safety and protection against the influence of external factors that may negatively affect the health of patients or the work of medical personnel.

### 3.2. What must be done for the conversion

MEDEVAC is defined as all regulated patient movement by the military's using predesigned tactical or logistic ground vehicles, aircraft (both fixed- wing and rotary), and watercraft medically equipped and staffed for en route care. Main principles of MEDEVAC for battlefield and tactical are medical intervention, speed, effectiveness, medical care, appropriateness, precedence [11].

The successful conversion process of a passenger aircraft into a medical aircraft relies on several key factors. These include meticulous selection of the appropriate aircraft model, careful consideration of the cabin layout and fuselage design, thorough evaluation of cabin functionality, and strategic implementation of necessary enhancements. By considering these factors, the transformation can be carrying out effectively, ensuring the optimal configuration of the aircraft to meet the specific requirements of a medical setting.

First, it is necessary to conduct a thorough analysis of the technical capabilities and limitations of the selected aircraft model, as this will allow determining its compliance with the requirements for medical use.

The next step is to search for specialized medical equipment that will ensure the provision of effective medical care on board the aircraft. For example, how to install monitoring systems, resuscitation kits, infusion systems and other necessary equipment that is required.

					<b>NAU 23 06L 00 00 00 52 EN</b>	<i>Sheet</i>
<i>Ch</i>	<i>Sheet</i>	<i>Document Nº</i>	<i>Sign</i>	<i>Date</i>		42

The third stage is to develop an optimal layout of the fuselage cabin, such as the placement of medics, patients and equipment. It is critical to create a comfortable and safe environment for medical care (fig. 3.3.).



Fig. 3.3. Medical beds in Airbus

For instance, the conversion of A330/A340 aircraft into Medevac configurations typically takes around five weeks from the signing of the contract, assuming the medical kit provided (fig. 3.4.).

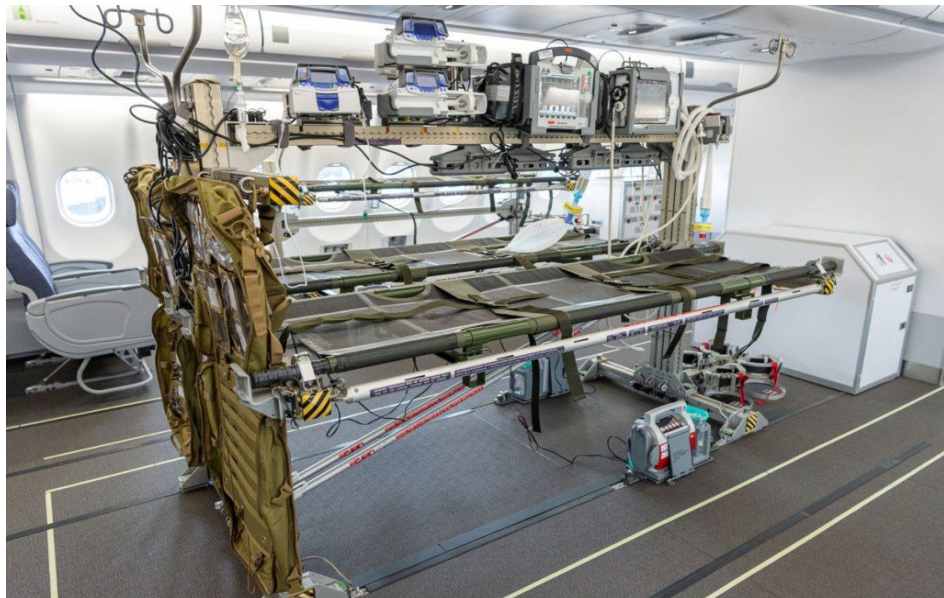

Fig. 3.4. Airbus says the A330/A340 platform can “quickly” converted

Ch	Sheet	Document Nº	Sign	Date

Next graphic arrangement focuses on the board of the CSA (Civil Safety Academy) airline, namely, the Boeing 737-800 aircraft, which are the most common characteristics with my diploma project main prototype B737-600 [12]. The sketch created based on the actual dimensions of the aircraft, medical equipment and facilities (fig. 3.5.).

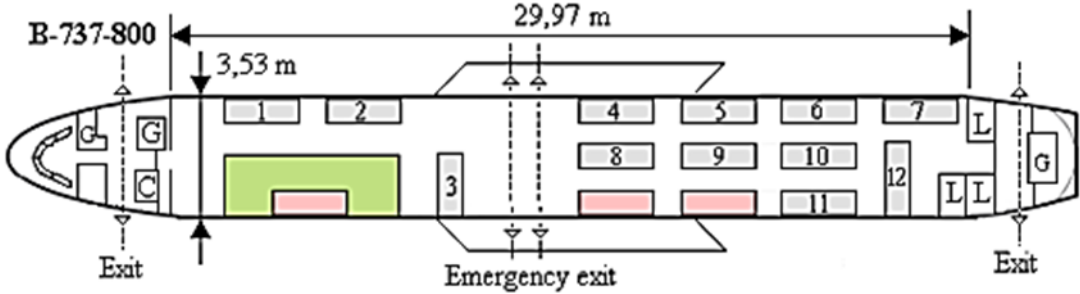

Fig. 3.5. B737-800 layout for MEDEVAC version

This aircraft boasts a spacious cabin, around 29 meters long and 3.53 meters wide that can be customizing for medical purposes. Within this cabin, three folding stretchers can be strategically place to accommodate patients, while above them; essential medical equipment can be stored conveniently. The medical team accompanying the patients can have their designated seating areas, ensuring their comfort and accessibility throughout the evacuation process.

To enhance patient transport capabilities, the rear section of the aircraft would house two Patient Transport Units (PTUs), which can utilized independently or in conjunction with bio bags for safe transportation. The remaining area within the cabin would be utilize to accommodate eight folding stretchers, ensuring sufficient capacity for patient care. Complementing the stretchers, designated storage boxes for medical supplies would strategically place, optimizing the efficient use of available space.

**3.3. Analysis of necessary equipment**

This part delves into the importance of selecting equipment for medical aircraft to achieve effective aeromedical operations.

The need for rapid patient transportation is growing, and medical aircraft have become indispensable for providing specialized medical care in remote and inaccessible regions.

Careful selection and deployment of the necessary equipment is imperative to maintain patient stability and provide optimal medical interventions during aeromedical missions.

The projected aircraft will be equipped with 2800 series modules manufactured by Spectrum Aeromed.

The 2800 Series medical evacuation modules manufactured by Spectrum Aeromed known for their excellent quality and high efficiency. These innovative systems are reliable helpers in providing life-saving medical care to patients during air transport.

The 2800 Series modules are flexible and adaptable to different types of aircraft, allowing them to be easily installed and removed from the aircraft. They are designed with advanced medical technology that ensures secure patient fixation, constant monitoring of their health status, and the ability to provide quick treatment. These modules provide the necessary safety and comfort for patients during evacuation.

These modules are impressive in their features and high level of functionality, making them a must-have for medical aviation applications.

The 2800 Series modules offer dual outputs for oxygen, medical air, and vacuum, ensuring a reliable and uninterrupted supply of the necessary resources for medical equipment and procedures. The intravenous attachments ensure stable and safe administration of medications, maximizing the efficiency and safety of patient care [13].

When it comes to patient comfort and safety, the 2800 Series modules offer a number of design features. Flame-retardant and easy-to-clean fabric stretchers provide comfortable support for patients, while their expandable armrests and adjustable backrests allow for customization of the position for maximum comfort and support.

The unique seat adapter makes the conversion of an aircraft from executive to emergency medical service configuration a quick and hassle-free process.

This ensures efficiency and effectiveness in emergencies without wasting much time on conversion. One of the key points of their functionalities is the ability to fix monitoring units and accessories using different models by tables.

The following equipment should be also installed in a medical aircraft in additional: cardiac Monitor, Defibrillator, Airway Control Devices, Non-Invasive Blood Pressure Monitors, Pulse Oximeters, X-ray system, End-Tidal CO2 Detectors, Intravenous Solutions, Cardiac and Emergency Medications Portable Ventilator, Medical Oxygen and Suction Systems, Power Inverter, Medications, medical stretcher, Satellite telephone. Below is a detailed description of the necessary equipment, its specifics and features of MEDEVAC. This list is only a part of the medical equipment on board a medical evacuation aircraft, but there may be additional equipment, depending on the location and purpose of medical care.

This photo show us variant of layout of medical evacuation aircraft in B737-800 (fig. 3.6.)



Fig. 3.6. Swedish National Air operates a Boeing 737-800 aircraft for their MEDEVAC missions

The configuration of an aeromedical flight team carefully designed. The composition of the crew is tailoring according to the nature of the mission at hand. However, it is not uncommon for physicians to be absent from the crew in routine air medical transport flights due to practical and financial considerations.

Nevertheless, the inclusion of diverse skill sets within mixed crews, such as physician-nurse, nurse-paramedic, or nurse-respiratory therapist, can often yield greater advantages compared to crews composed of individuals with similar training backgrounds, such as nurse-nurse or paramedic-paramedic.

This amalgamation of expertise allows for a comprehensive range of abilities, enabling the team to address various aspects of patient care with enhanced proficiency. By bringing together professionals from different disciplines, the collective knowledge and experience contribute to a more comprehensive and well-rounded approach to air medical transport.

Recognizing the unique strengths and capabilities of each team member and fostering collaboration between different specialties results in a dynamic and synergistic environment. The collaboration among professionals with diverse training backgrounds facilitates effective problem-solving, efficient resource allocation, and the ability to adapt to unexpected challenges during aeromedical missions. This diversity in skills and perspectives ultimately promotes the delivery of optimal care and enhances the overall effectiveness of the air medical transport team.

Before initiating transportation, it is vital to conduct a comprehensive assessment of the positioning and functionality of tubes, lines, and drains, as it can be challenging or even impossible to insert new ones during the flight. The transport team must ensure that all intravenous lines are both aspirated and infused with fluids, meticulously inspect arterial line waveforms and the accuracy of blood pressure readings.

Additionally, it is crucial to verify the correct placement of endotracheal tubes (ETTs) through X-ray examination and thoroughly examine all circuits to detect and address any potential leaks.

By diligently assessing the status and functionality of tubes, lines, and drains before embarking on the journey, the transport team can mitigate potential risks and

complications that may arise during the flight. This proactive approach ensures that necessary adjustments and interventions made in a controlled and preparatory manner, contributing to the overall safety and well-being of the patients throughout the transport.

There are multiple options for securing the stretchers in the aircraft. One method is by attaching them directly to the seat tracks, while another option is to secure them to a support unit that connected to the aircraft structure.

It is important to note that the stretchers and their support units must meet the requirements outlined in §25.561 by EASA (European Union Aviation Safety Agency). However, they do not comply with the specifications stated in §25.562. This photo show example for bed with stretchers (fig. 3.7.).



Fig. 3.7. Aeromed stretcher

Electrocardiogram (ECG) monitoring plays a crucial role in the care of critically ill patients during transportation. It is essential for detecting arrhythmias, identifying signs of myocardial ischemia or injury, and diagnosing pulseless electrical activity, especially during long-range aeromedical evacuation.

Therefore, it is imperative to address and minimize such interferences to ensure the integrity of the monitoring process.

Arterial blood oxygen saturation (SO<sub>2</sub>) and endtidal carbon dioxide in exhaled air (EtCO<sub>2</sub>) are basic indicators of cardiopulmonary function.



Because clinical evaluation of patients is difficult in the AE environment, continuous monitoring of SO<sub>2</sub> via pulse oximetry and ETO<sub>2</sub> via capnography has been standard for critically ill patients during aircraft evacuation.

A portable ventilator plays an important role in providing respiratory support and breathing to patients who have breathing problems or have lost the ability to breathe on their own.

On board a medical aircraft, a defibrillator proves to be an integral component for immediate intervention and restoration of a normal heart rhythm, which can literally save a patient's life. As an integral part of the emergency medical care chain, a defibrillator on a medical aircraft is used as an extremely important medical device that uses an electric shock to restore a normal heart rhythm and give the patient a chance to return to life. The photo shows a variant of the patient's bed and medical equipment (fig. 3.8.).



Fig. 3.8. Variant of location

Power inverters installed in medical aircraft to convert the aircraft's direct current (DC) electrical power to alternating current (AC). This allows medical equipment, such as monitors, ventilators, or infusion pumps, to be power and operated during transport, ensuring continuous patient monitoring and medical interventions.

Medical airplanes outfit with an extensive assortment of medications specifically intended for cardiac emergencies. This includes antiarrhythmic, vasopressors, and thrombolytic, among others. These medications are readily accessible on board to promptly respond to critical situations and stabilize patients who are encountering cardiac events or other life-threatening emergencies.

Such a comprehensive array of medications ensures that medical professionals have the necessary resources at their disposal to effectively manage cardiac emergencies and provide the best possible care to patients in need.

### **3.3.1. Technical characteristics of installed equipment**

To calculate the number of beds for patients, you should take into account the size of the bed, a wide aisle for free and safe movement of people, movement of medical equipment and medicines, and quick movement to the exit.

The bed length of such a module will be 190.5 cm, width – 43.25 cm and weight near 130 kg.

The width of medical chairs usually ranges from about 40 to 60 centimeters (16 to 24 inches) to provide sufficient space for medical personnel and ensure a comfortable working environment. Federal Aviation Administration has regulations and requirements, particularly in Part 25 (FAR 25.785), that relate to crew seats or seats on commercial aircraft.

The medical staff will consist of two pairs of medical crews, which will consist of two medical specialists, and nurses and paramedics, i.e. 8 people.

This composition of medical staff will ensure the necessary level of care and medical assistance to patients during medical evacuation.

### **3.4. Center of gravity of medical aircraft**

Calculating the centering of a medical aircraft is a fundamental step. It is necessary to ensure flight stability and optimal functioning of the medical devices during patient transportation.

During this process, the weight and moment arrangement in the aircraft must be adjust to achieve stability and avoid controllability issues. In a medical aircraft, varieties of factors are taken into account when calculating centering, which makes it different from passenger flights. In addition to the general requirements for passenger seating and weight, special consideration make for medical facilities and their impact on centering.

In order to achieve optimal weight distribution in the aircraft, changes can be implement in the positioning of movable healthcare devices. This allows reaching the right balance, taking into account the specifics of medical needs and flight conditions. We also need to take into account the medical staff who help to keep patients stable.

The basic calculations remain unchanged, since the centering of the wing, tail, landing gear, and systems does not change when converting a passenger aircraft into a medical emergency evacuation aircraft. That is why Table 1.3. is relevant for further calculation.

### 3.4.1. Trim-sheet of the equipped fuselage masses

Table 3.1.

**Trim sheet of equipped fuselage of medical aircraft**

№	Objects names	Mass		C.G coordinates Xi, m	Moment of mass
		Units	Total mass		
1	Fuselage	0.09403	5708.27	15.935	90961.42
2	Horizontal tail	0.00998	605.85	13.38	8106.35
3	Vertical tail	0.00985	597.96	3.34	1997.19
4	Navigation	0.0049	297.46	2	594.92
5	Radar	0.0033	200.33	1	200.33
6	Radio	0.0025	151.76	1	151.76
7	Instrument panel	0.0058	352.10	2	704.20
8	Flight control 70%	0.00455	276.21	15.935	4401.51
9	Hydraulic system 30%	0.00525	318.71	22.309	7110.14

Continue Table 3.1.

№	Objects names	Mass		C.G coordinates Xi, m	Moment of mass
		Units	Total mass		
10	Anti-ice system, 25%	0.005375	326.3001	25.496	8319.34
	Air-conditioning system, 25%	0.005375	326.3001	15.935	5199.59
11	Electrical equipment, 90%	0.02979	1808.461	15.935	28817.83
12	Lining and insulation	0.0085	516.009	16.925	8733.46
13	Not typical equipment	0.004	242.82	3	728.48
14	Additional equipment	0.00401	243.43	5	1217.17
15	Operational items	0.002194	133.19	26	3462.97
16	Lavatory1, galley1 20%	0.00385	233.72	2.96	691.81
	Lavatory2, galley 2 20%	0.00385	233.72	27	6310.49
17	Medical beds (modules)	0.085657338	4940	15	74100
	Seats of medics	0.001054244	64	7	448
	Seats of pilots	0.000658903	40	1.48	59.2
18	Patience	0.04694681	2850	15	42750
	Medicines, additional staff	0.009554088	580	18	10440
	Baggage, equipment, meal	0.025532476	1550	27.28	42284
	Crew	0.011036619	670	3	2010
	TOTAL	0.38326161	23266.66	15.03	349800.24
	TOTAL fraction for checking	1.00001061	60707.64		

The precise location information of the center of mass for the equipped fuselage in medical plane obtained through the utilization of a formula:

$$x'_{wm} = \frac{\sum m'_i x'_i}{\sum m'_i} = \frac{349800.24}{23266.66} = 15.03 \text{ m,}$$

Where  $\sum m_i' x_i'$  - total moment of mass of fuselage,  $\sum m_i'$  - total mass.

### 3.4.2 Calculation of center of gravity positioning variants

Table 3.2.

#### Calculation of C.G. positioning variants

Name object	Mass, Kg $m_i$	Coordinate C.G., M	Mass moment Kg.m
Equipped wing	16916.55	15.10	255403.97
Nose landing gear (extended)	184.31	10.98	2023.68
Main landing gear (extended)	1044.403	17.65	18433.72
Fuel reserve	2310.51	17.36	40110.43
Fuel for flight	16985.21	17.36	294863.27
Equipped fuselage (without payload)	17616.66	14.32	252316.24
Patience	2850	15.00	42750.00
Medicines, additional staff	580	18.00	10440.00
Baggage, additional equipment, meal	1550	27.28	42284.00
Crew	670	3.00	2010.00
Nose landing gear (retracted)	184.306452	10.98	2023.68
Main landing gear (retracted)	1044.403228	17.65	18433.72

Table 3.3.

**Airplanes C.G. position variants**

<b>№</b>	<b>Variants of the loading</b>	<b>Mass, kg</b>	<b>Moment of the mass, kg*m</b>	<b>Center of mass, m</b>
1	Take off mass (L.G. extended)	60707.64	960635.31	15.82
2	Take off mass (L.G. retracted)	60707.64	960635.31	15.82
3	Landing weight (LG extended)	43722.43	665772.04	15.22
4	Ferry version	55727.64	865161.31	15.52
5	Parking version	38072.43	568288.04	14.92

## Conclusion to the special part

The part on the conversion of a passenger aircraft into a medical aircraft for the evacuation of wounded and sick military personnel presented the importance and relevance of this process.

The conversion process involves the installation of specialized equipment such as medical beds, monitoring and life support systems, as well as modification of control and avionics systems to ensure patient safety and transportation efficiency.

It is important to emphasize that the centering of the medical aircraft does not disrupt the balance between patient safety and comfort. Safety is a priority in the design of medical aircraft, and all necessary medical protocols and standards are taken into account. At the same time, patient comfort ensured in order to minimize discomfort and stress during transportation by medical aircraft.

During the centering of the aircraft, work done to accurately calculate and position medical equipment, medical beds, and other necessary devices in the interior space.

In addition, the conversion of a passenger aircraft into a medical aircraft is a cost-effective solution, as it allows the use of existing resources and avoids the need to build or purchase new aircraft.

This conversion helps to increase the chances of survival and recovery of wounded soldiers, as well as to ensure efficient use of available aviation resources. This process is important for ensuring the safety and well-being of the military in critical situations and war, which is relevant for Ukraine.

					<i>NAU 23 06L 00 00 00 52 EN</i>	Sheet
<i>Ch</i>	<i>Sheet</i>	<i>Document №</i>	<i>Sign</i>	<i>Date</i>		55

## GENERAL CONCLUSIONS

My airplane preliminary design project was devoted to the detailed study and development of various aspects related to the design and functionality of the aircraft. A number of tasks performed, which gave me an understanding of the process of creating an airplane and introduced me to all the technical features and geometric data of the airplane.

Geometric calculations of the wing, fuselage, cabin, kitchens and toilets performed to ensure the optimal shape, size and materials for each component. This helped to maximize efficiency, safety and passenger comfort.

A special topic about the conversion of the aircraft into a medical one was an important element of the thesis. This conversion creates great opportunities to provide medical care and evacuate injured and sick military personnel in emergency cases. It is both relevant and in line with the needs of the modern military sector.

At the center of the research and development of this thesis was an extremely important goal - to create an aircraft that satisfies the highest standards of safety, comfort and functionality. The results of this research open up broad prospects for the further development and improvement of the aviation industry, in particular for the design and manufacture of aircraft for various applications.

The careful research and analysis done as part of this project provided me with a good understanding of all phases of aircraft design. It has expanded my knowledge of the importance of geometric measurement, aircraft center of gravity, and passenger cabin design, and highlighted the importance of consideration of specific requirements and specifications. The findings provide a great basis for further work on the development and improvement of the aircraft, contributing to the successful realization of our project.

					<b>NAU 23 06L 00 00 00 52 EN</b>		
	<i>Sh.</i>	<i>Nº doc.</i>	<i>Sign</i>	<i>Date</i>			
<i>Done by</i>	Liashenko Y.A.				<b>General conclusion</b>		
<i>Checked by</i>	Zakiev V.I.						
<i>St.control.</i>	Krasnopolskyi V.S.				<i>list</i>	<i>sheet</i>	<i>sheets</i>
<i>Head of dep.</i>	Ignatovich S.R.					56	68
					<b>402 ASF 134</b>		



## REFERENCE'S

1. Online resource: <http://www.b737.org.uk/techspecs/detailed.htm>
2. Online resource:  
<https://booksite.elsevier.com/9780340741528/appendices/data-a/table-1/table.htm>
3. Online resource: <https://studfile.net/preview/7622686/page:2/>
4. Online resource: <https://aerotoolbox.com/fuselage-structure/>
5. Online resource: <https://aerotoolbox.com/intro-fuselage-design/>
6. Online resource: <https://sassofia.com/blog/aircraft-emergency-exit-configurations-requirements/>
7. Online resource: <https://www.studyaircrafts.com/landing-gear-system>
8. Основи авіації (вступ до спеціальності): підручник / С.Р. Ігнатович, О.В. Попов, В.О. Максимов та ін. – К.: НАУ, 2023. – 296 с.
9. Online resource: <https://www.skybrary.aero/articles/centre-gravitycg>
10. Online resource: <https://runwaygirlnetwork.com/2020/08/airbus-embraer-each-offer-medevac-conversions-for-aircraft/>
11. William W. Hurd • William Beninati Editors. Aeromedical Evacuation. Management of Acute and Stabilized Patients Second Edition. Springer Nature Switzerland AG 2019.
12. Kozuba, J., Pila, J., Martinec, F. Analysis of possible modification of transport aircraft to MEDEVAC in the Czech Republic. Scientific Journal of Silesian University of Technology. Series Transport. 2023, 118, 109-121:  
[https://sjsutst.polsl.pl/archives/2023/vol118/109\\_SJSUTST118\\_2023\\_Kozuba\\_Pila\\_Martinec.pdf](https://sjsutst.polsl.pl/archives/2023/vol118/109_SJSUTST118_2023_Kozuba_Pila_Martinec.pdf)
13. Online resource: <https://spectrum-aeromed.com/air-medical-equipment/modular-advanced-units/2800-series/>

					NAU 23 06L 00 00 00 52 EN				
	<i>Sh.</i>	<i>Nº doc.</i>	<i>Sign</i>	<i>Date</i>					
<i>Done by</i>	Liashenko Y.A.				Reference`s		<i>list</i>	<i>sheet</i>	<i>sheets</i>
<i>Checked by</i>	Zakiev V.I.							57	68
<i>St.control.</i>	Krasnopolskyi V.S.						402 ASF 134		
<i>Head of dep.</i>	Ignatovich S.R.								

# Appendix

**Appendix A**  
**INITIAL DATA AND SELECTED PARAMETERS**

Passenger Number 110

Flight Crew Number 2

Flight Attendant or Load Master Number 5

Mass of Operational Items 1331, 67kg

Payload Mass 11495, 00kg

Cruising Speed 828 km/h

Cruising Mach Number 0.7760

Design Altitude 11.00 km

Flight Range with Maximum Payload 5648km

Runway Length for the Base Aerodrome 2.55km

Engine Number 2

Thrust-to-weight Ratio in N/kg 2.7800

Pressure Ratio 32.80

Assumed Bypass Ratio 5.00

Optimal Bypass Ratio 5.00

Fuel-to-weight Ratio 0.2850

Aspect Ratio 9.45

Taper Ratio 3.50

Mean Thickness Ratio 0.120

Wing Sweepback at Quarter Chord 27.0

High-lift Device Coefficient 1.100

Relative Area of Wing Extensions 0.020

Wing Airfoil Type supercritical

Winglets yes

Spoilers yes

					<b>NAU 23 06L 00 00 00 52 EN</b>	<i>Sheet</i>
<i>Ch</i>	<i>Sheet</i>	<i>Document N°</i>	<i>Sign</i>	<i>Date</i>		59

Fuselage Diameter 4.01m  
Finess Ratio 7.95  
Horizontal Tail Sweep Angle 30.0  
Vertical Tail Sweep Angle 35.0

### CALCULATION RESULTS

Optimal Lift Coefficient in the Design Cruising Flight Point 0.46846  
Induce Drag Coefficient 0.00915

ESTIMATION OF THE COEFFICIENT  $D_m = M_{critical} - M_{cruise}$

Cruising Mach Number 0.77599  
Wave Drag Mach Number 0.78394  
Calculated Parameter  $D_m$  0.07796

Wing Loading in kPa (for Gross Wing Area):

At Takeoff 5.391  
At Middle of Cruising Flight 4.493  
At the Beginning of Cruising Flight 5.192

Drag Coefficient of the Fuselage and Nacelles 0.01341

Drag Coefficient of the Wing and Tail Unit 0.00917

Drag Coefficient of the Airplane:

At the Beginning of Cruising Flight 0.03419  
At Middle of Cruising Flight 0.03277

Mean Lift Coefficient for the Ceiling Flight 0.46846

Mean Lift-to-drag Ratio 14.29545

Landing Lift Coefficient 1.670

Landing Lift Coefficient (at Stall Speed) 2.5.5

Takeoff Lift Coefficient (at Stall Speed) 2.055

Lift-off Lift Coefficient 1.500

Thrust-to-weight Ratio at the Beginning of Cruising Flight 0.632

					<b>NAU 23 06L 00 00 00 52 EN</b>	Sheet
Ch	Sheet	Document Nº	Sign	Date		60

Start Thrust-to-weight Ratio for Cruising Flight 2.642

Start Thrust-to-weight Ratio for Safe Takeoff 2.971

Design Thrust-to-weight Ratio 3.090

Ratio  $D_r = R_{\text{cruise}} / R_{\text{takeoff}}$  0.889

SPECIFIC FUEL CONSUMPTIONS (in kg/kN\*h):

Takeoff 36.3033

Cruising Flight 57.6041

Mean cruising for Given Range 60.4593

FUEL WEIGHT FRACTIONS:

Fuel Reserve 0.03806

Block Fuel 0.27979

WEIGHT FRACTIONS FOR PRINCIPAL ITEMS:

Wing 0.11125

Horizontal Tail 0.00998

Vertical Tail 0.00985

Landing Gear 0.02024

Power Plant 0.09333

Fuselage 0.09403

Equipment and Flight Control 0.12823

Additional Equipment 0.00401

Operational Items 0.02194

Fuel 0.31785

Payload 0.18935

Airplane Takeoff Weight 60707 kG

Takeoff Thrust Required of the Engine 93.79kN

Air Conditioning and Anti-icing Equipment Weight Fraction 0.0215

					<b>NAU 23 06L 00 00 00 52 EN</b>	Sheet
Ch	Sheet	Document Nº	Sign	Date		61

Passenger Equipment Weight Fraction

(or Cargo Cabin Equipment) 0.0148

Interior Panels and Thermal/Acoustic Blanketing Weight Fraction 0.0085

Furnishing Equipment Weight Fraction 0.0077

Flight Control Weight Fraction 0.0065

Hydraulic System Weight Fraction 0.0175

Electrical Equipment Weight Fraction 0.0331

Radar Weight Fraction 0.0033

Navigation Equipment Weight Fraction 0.0049

Radio Communication Equipment Weight Fraction 0.0025

Instrument Equipment Weight Fraction 0.0058

Fuel System Weight Fraction 0.0093

Additional Equipment:

Equipment for Container Loading 0.0000

No typical Equipment Weight Fraction 0.0040

(Build-in Test Equipment for Fault Diagnosis,  
Additional Equipment of Passenger Cabin)

TAKEOFF DISTANCE PARAMETERS

Airplane Lift-off Speed 272.90 km/h

Acceleration during Takeoff Run 2.36 m/s\*s

Airplane Takeoff Run Distance 1215 m

Airborne Takeoff Distance 578 m

Takeoff Distance 1793 m

Decision Speed 259.25 km/h

Mean Acceleration for Continued Takeoff on Wet Runway 0.25 m/s\*s

Takeoff Run Distance for Continued Takeoff on Wet Runway 2220.88 m

Continued Takeoff Distance 2799.2 m

					<i>NAU 23 06L 00 00 00 52 EN</i>	Sheet
Ch	Sheet	Document Nº	Sign	Date		62

Runway Length Required for Rejected Takeoff 2899.44 m

### LANDING DISTANCE PARAMETERS

Airplane Maximum Landing Weight 46297 kg

Time for Descent from Flight Level Aerodrome Traffic Circuit Flight 21.8 min

Descent Distance 50.05 km

Approach Speed 242.86 km/h

Mean Vertical Speed 1.97 m/s

Airborne Landing Distance 514 m

Landing Speed 227.86 km/h

Landing run distance 701 m

Landing Distance 1215 m

Runway Length Required for Regular Aerodrome 2029 m

Runway Length Required for Alternate Aerodrome 1725 m

					<b>NAU 23 06L 00 00 00 52 EN</b>	Sheet
Ch	Sheet	Document Nº	Sign	Date		63

**Appendix B**  
Center of gravity of the wing

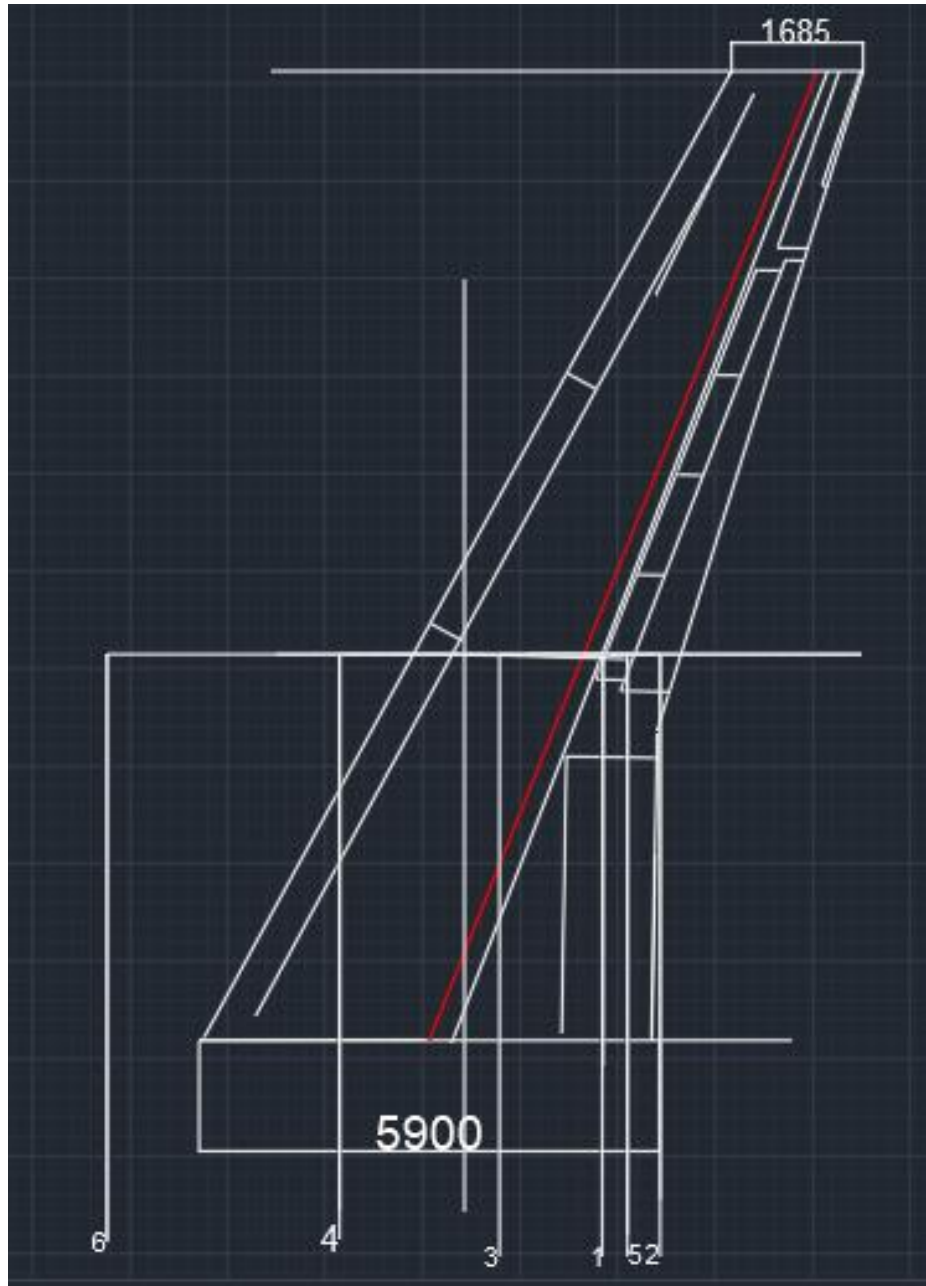

Ch	Sheet	Document N°	Sign	Date

*NAU 23 06L 00 00 00 52 EN*



## Appendix B

### Coordinate positions

Wing, fuel system, fuel	1
Flight control system, hydraulic system	2
Electricity equipment, anti-ice system	3
Engines(without fuel)	4
Main landing gear	5
Nose landing gear	6

## Appendix C

### Center of gravity of fuselage

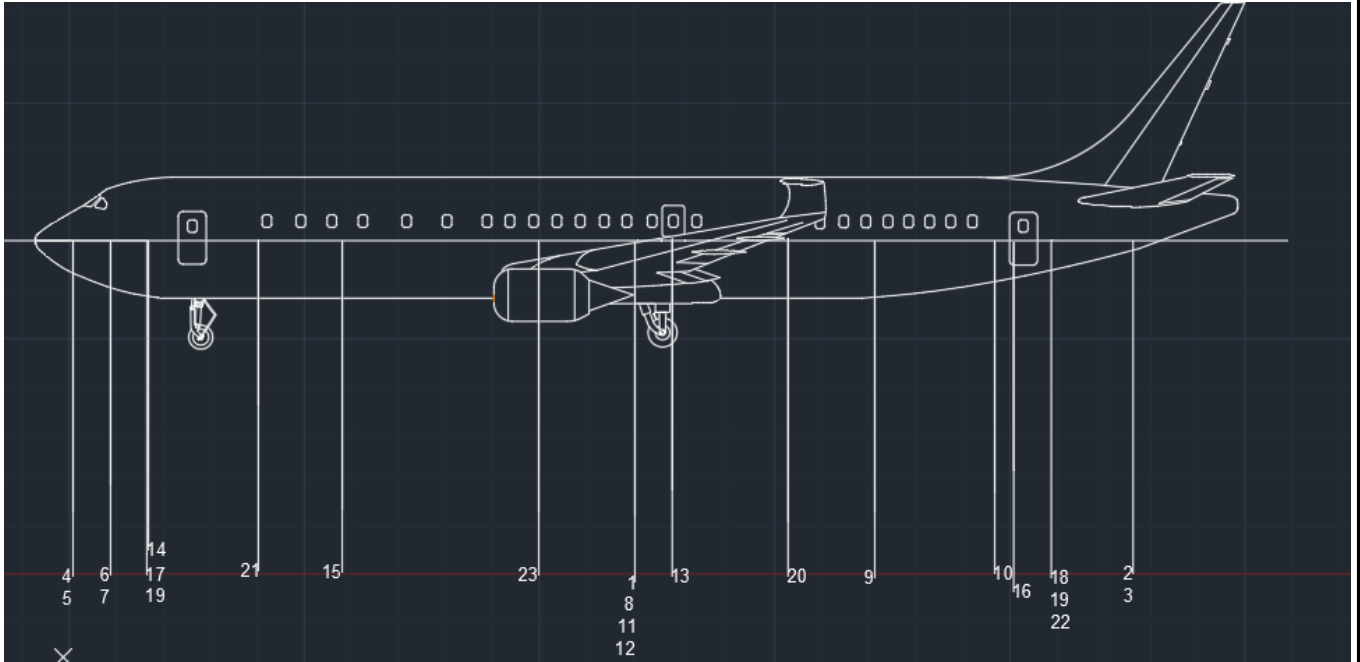

## Appendix C

### Coordinate position

Fuselage	1
Horizontal tail	2
Vertical tail	3
Radar	4
Radio equipment	5
Navigation equipment	6
Instrument panel	7
Flight control system	8
Hydraulic system	9
Anti-ice system	10
Air-conditioning system	11
Electrical equipment	12
Lining and insulation	13
Not typical equipment	14
Emergency equipment	15
Operational items	16
Lavatory 1	17
Lavatory 2	18
Galleys	19
Passenger seats (economy class)	20
Passenger seats (business class)	21
Onboard meal	22
Passengers	23

# Appendix D

## Center of gravity of medical fuselage

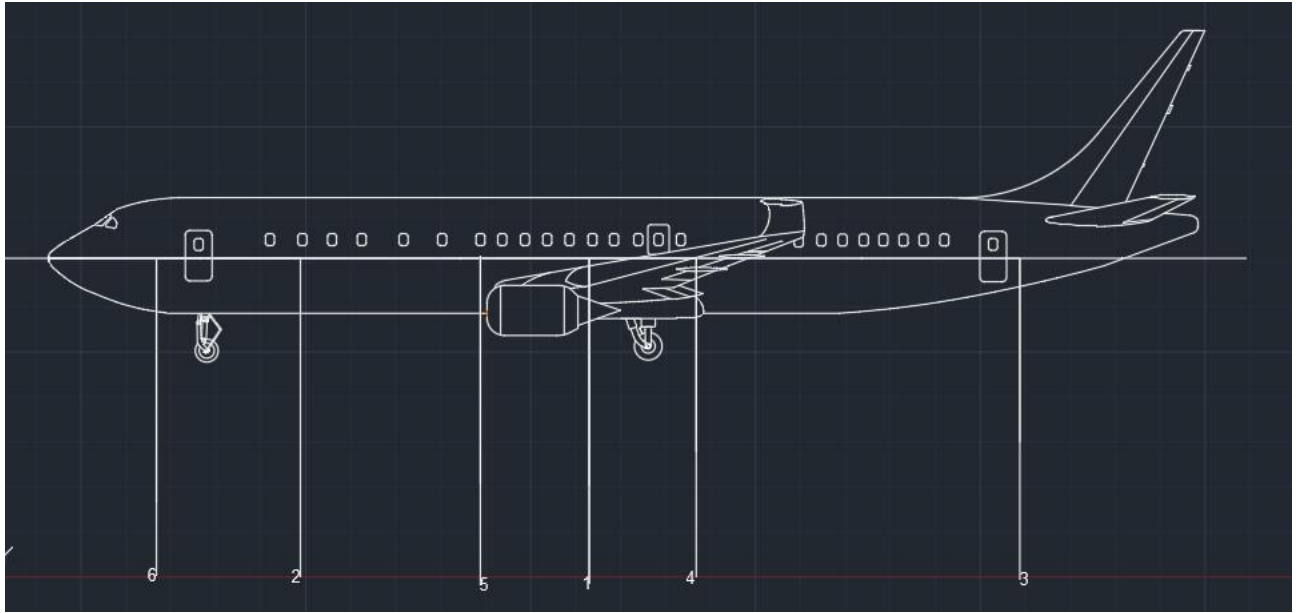

## Appendix D

### Coordinate position

Medical modules	1
Seats of medics	2
Baggage, equipment, meal	3
Medicines, additional baggage	4
Patience	5
Crew	6